



THE FORD METER BOX COMPANY, INC.
CERTIFIED TO ISO 9001:2015
10002505

Section E

09/2018



Ford[®] Yokes and Yoke Parts



Contents

Advantages of Ford Yokes	3
Yoke Piece Support Prongs	3
Features of Ford Yokes	4
Ford Meter Yokes	
Riser Yokes	5
Angle Yokes	5
Straight Yokes	5
Yoke Parts	
Parts Requirement for Complete Yoke Assembly	5
Meter Dimensions	5
Yoke Bars	6
Expansion Connections	6
Angle Yoke Ball Valves	7
Angle Yoke Key Valves	7
Angle Yoke Compression Valves	8
Straight Yoke Ball Valves	8
Straight Yoke Outlet Pieces	9
Yoke Ells	9
Angle Cartridge Dual Check Valves	10
Straight Cartridge Dual Check Valves	10
Angle Dual Check Valves	10
Straight Dual Check Valves	10
Angle Check Valves	10
Straight Check Valves	11
Gaskets	11
Lock Nuts	11
Expansion Connection Wrenches	11
Spanner Wrench for Lock Nuts	11
Lock Caps	11
Warranty	12

Ford offers many products that are classified to ANSI/NSF Standard 61. To verify if a product is classified to ANSI/NSF Standard 61, contact the Ford Meter Box Customer Service Department at 260-563-3171 or visit fordmeterbox.com. Ford Meter Box meets your need for ANSI/NSF Standard 61 approved items with products that are proven and reliable.

Due to design improvements, product images in the catalog do not always reflect the most current design detail.

Ford Meter Box no-lead brass products manufactured from UNS/CDA No. 89833 alloy shall contain no more than 0.25% total lead content by weight. United States federal and state laws allow the use of products manufactured from UNS C83600 85-5-5-5 brass alloy for only non-potable water systems within the United States.

Ford, Ford Meter Box and Uni-Flange are trademarks of The Ford Meter Box Company, Inc. registered in the U.S.

Advantages of Ford Yokes

Ford Yokes provide a convenient and durable setting for water meters and make meter change-outs easier. They also provide substantial savings over meter couplings, valves, curb boxes and pipe fittings, which are eliminated in many cases.

STABILITY

Ford Yokes provide proper spacing and alignment to support the water meter and the water lines. The strong iron yoke piece becomes a permanent part of the piping structure, holding the inlet and outlet pipes, of any material, braced and correctly spaced.

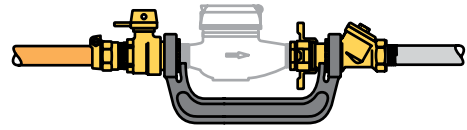

ACCESSIBILITY

Meter changes with Ford Yokes are quick and trouble-free. Meters tend to be better maintained, kept more accurate and utilized more efficiently when easily accessible. Readily accessible meters, in Ford Yokes, earn more for the water utility.

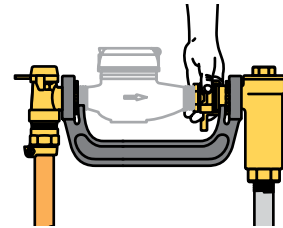

VERSATILITY

Ford Yoke Settings can include a variety of valve styles at either the inlet or outlet. Being close-coupled to the Yoke piece, the valves are easily inspected and operated. Angle yoke valves and ells can be rotated to connect to piping from below, above or behind.

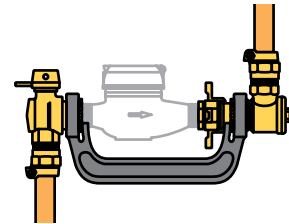

SECURITY

When a meter is removed from a Ford Yoke, the Expansion Connection is also removed. Since an Expansion Connection is required to complete the installation, its absence helps prevent unauthorized water use.

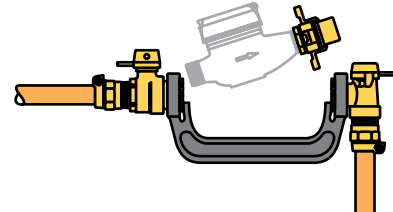

Yoke Piece Support Prongs

500P SERIES

For use when connecting yoke setting to plastic service lines

500 Series Yoke pieces are available with integral prongs at the bottom of the casting. When a riser Yoke is connected to a plastic pipe or tubing service line, support of the Yoke is necessary. A 3/4" iron pipe stake of desired height is driven into the soil and a prong on the Yoke is inserted to hold the meter setting in the proper position and elevation.

Note: The Y504P Yoke has one prong.

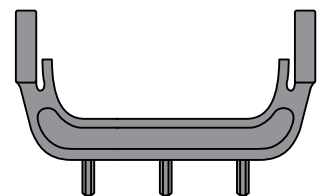

TYPES OF PIPE AND TUBING - EXPLANATION OF ABBREVIATIONS AND CODES FOR COMPRESSION COUPLINGS

Copper Tube - CTS - Copper tubing is widely used as a service line and the outside diameter is closely held by manufacturers. The outside diameter of copper tubing has become a standard in the industry and is known as "copper tube size." (Pack Joint coded **CTS**.)

Plastic Tube - CTS - Flexible water service tubing in what is referred to as "copper tube size." Plastic tube refers to any plastic with the same outside diameter as corresponding sizes of copper tube such as PET - Polyethylene tubing. (Pack Joint coded **CTS**.)

Plastic Pipe - PEP - Flexible water service pipe in what is referred to as "pipe size." Plastic pipe refers to any pipe having the same inside diameter as corresponding sizes of standard iron pipe such as PEP - Polyethylene pipe. (Pack Joint coded **PEP**.)

PVC Pipe - PVC - Polyvinyl Chloride rigid plastic pipe. PVC Pipe refers to polyvinyl chloride rigid plastic pipe having the same outside diameter as corresponding sizes of standard iron pipe. (Pack Joint coded **PVC**.)

NOTE: Ford Pack Joints for PVC are recommended for use only with Schedule 40 and Schedule 80 PVC. Insert Stiffeners for plastic tubing are listed in Catalog Section G.

Features of Ford Yokes

The Expansion Connection

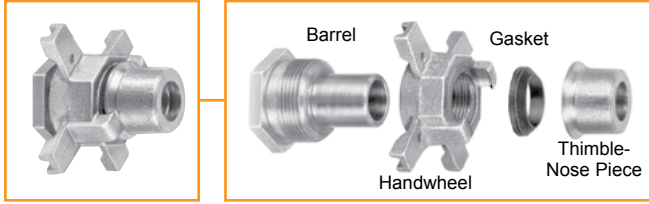

Every Ford Yoke setting requires an Expansion Connection. Screwed onto one end of a meter, it expands by turning the handwheel to make compression joints dependably and permanently water-tight against the fixed rubber gaskets in Yoke ends. When the connection is retracted, the meter is released and can be removed. Alignment and spacing of service lines is rigidly maintained by the cast iron yoke piece.

All Expansion Connections of a given size are interchangeable so that they can be left on meters for transfer.

The Expansion Connection is tightened on the meter with an ordinary wrench. The assembly becomes an expandable unit that can be installed or removed in a matter of seconds.

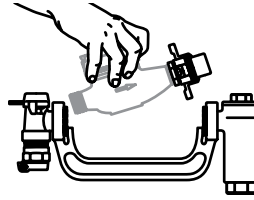

The meter and Expansion Connection assembly is placed in the saddles of the Yoke and aligned between the rubber gaskets in the ends of the Yoke.

Turning the handwheel of the Expansion Connection allows the meter installation to become water-tight quickly and easily. No wrench is required in the meter pit for meter changing.

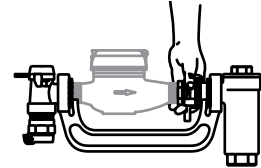

The unique three-piece design of the Ford Expansion Connection offers these important advantages over a two-piece design.

1. Ford's large, tapered expansion gasket is impervious to the cutting action of sand and grit – fragile "O" rings are not.
2. The thimble nose piece on the Ford Expansion Connection does not continue to rotate after making contact with the rubber yoke end gasket. Two-piece designs continue to rotate and may "walk out" of the yoke.
3. Not all sizes of competitive expansion connections fit into Ford Yokes. Ford has offered complete interchangeability for over 85 years.

Valves on Ford Yokes

All valves and plain brass ends of Ford Yokes are attached securely to the iron yoke piece by brass lock nuts. The valve is thus close-coupled, easily inspected and operated, and provides convenient control of the service. In pit settings it can replace the ordinary curb stop and curb box. Besides improved operations, Ford Yoke settings reduce material and maintenance costs. Pictures and detailed descriptions of the various types of valves available are shown below.

Angle Inverted Key Valves

Angle Inverted Key Valves are made for most service line types. Keys are held in position by strong bronze pins and spring washers. The cut-away picture at right shows inner construction of the angle type valve. Note correct design which ensures a minimum loss of pressure. See the following pages for the variety of connections that are available on Ford Key Valves.

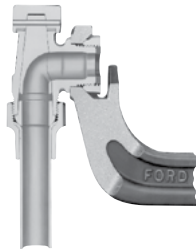

Expansion Connection with Check Valve(s) with or without locking mechanism

A fast, easy way to incorporate a backflow preventer, the 5/8" and 5/8" x 3/4" expansion connection can be ordered with dual check valves. The 1" shall have only one check valve. All sizes available with the locking feature to discourage unauthorized removal of the meter.



Test Valves

Inverted Key Valves as well as other connections for all types of Ford Yokes, are available with test valves to check meter operation, relieve pressure, or drain lines. The bronze screw tightens easily against a Teflon* seat forming a water-tight seal.

* Teflon is a trademark of the Dupont Corp.



Outlet Yoke Single and Dual Check Valves

Spring-loaded Check Valves and Dual Check Valves are available as yoke outlets in both Straight and Angle styles. The unique access cap position on the Cartridge Angle Dual Check Valve pictured at right provides easy access. For available pipe connections, see Check Valves on page 10.



Compression Valves

Pictured at right is the straight Compression type valve. This valve is also available in an angle pattern. Compression Valves are often placed at the yoke outlet as customer service valves.



Ball Valves

Straight and Angle Ball Valves are available for most Ford Yokes. The ease of operation and all other Ball Valve advantages are described in Section G.



Double Yoke Settings

Double Settings using Ford Yokes offer advantages by reducing material as well as labor costs. Meter reading time is also reduced. Yoke Valves are connected to Branch Pieces, as described in Section H. Tandem/Twin Yoke settings are also available.

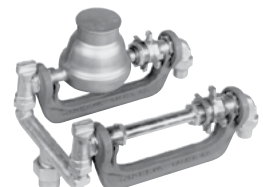

Ford Meter Yokes

The drawings below show three sample combinations of Riser Yoke and Angle Yoke Assemblies. A wide variety of end connections are available to best suit your water service needs.

Riser Yokes

- Vertical Inlet, Vertical Outlet
- AV94-323W-NL Angle Key Valve at Yoke Inlet
- HHCA91-323-NL Angle Cartridge Dual Check Valve at Yoke Outlet

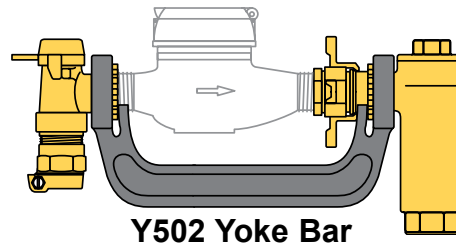

Y502 Yoke Bar

Angle Yokes

- Vertical Inlet, Horizontal Outlet
- BA94-323W-NL Angle Ball Valve at Yoke Inlet
- HHCH91-323-NL Straight Accessible Dual Check Valve at Yoke Outlet

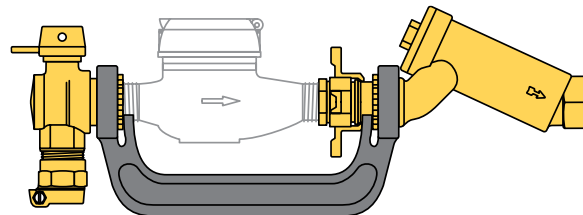

Y502 Yoke Bar

Straight Yokes

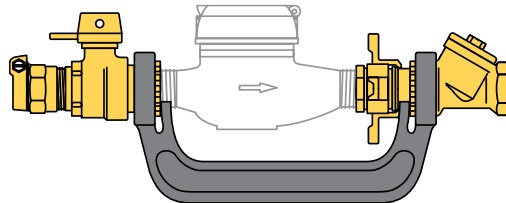

- Horizontal Inlet, Horizontal Outlet
- B94-323W-NL Straight Ball Valve at Yoke Inlet
- HS91-323-NL Straight Accessible Single Check Valve at Yoke Outlet



Y502 Yoke Bar

Ford Yoke Parts

A complete yoke assembly includes four parts.

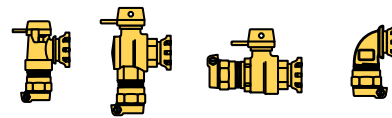
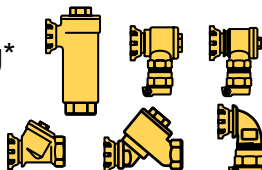
<p>1. Iron Yoke Piece</p> 	<p>2. Expansion Connection (for tightening meter to Yoke Valves and fittings)</p> 
<p>3. Inlet Valve or Coupling*</p> 	<p>4. Outlet Valve or Coupling* (except on 200 series with integral iron outlet)</p> 

***Note:** All ells, couplings, and valves, except angle ball valves, check valves and dual check valves, can be used on either end of a yoke. **Make sure you have ordered four parts for each complete Yoke assembly (only three parts are needed for series 200 Yokes).** Each expansion connection includes two rubber yoke end gaskets for sealing against inlet and outlet fittings.

Meter Dimensions

CATALOG No.	5/8"	5/8"x3/4"	3/4"	1"
LENGTH	7-1/2"	7-1/2"	9"	10-3/4"
THREAD SIZE	3/4" NPS	1" NPS	1" NPS	1-1/4" NPS

The Ford Meter Box Company recognizes "standard" dimensions when referring to meter size.

Ford Yoke Parts

Continued

Yoke Bars

500 Series

Yokes for use with removable brass end pieces.



CATALOG No.	Y501	Y502	Y503	Y504
METER SIZE	5/8"	5/8"x3/4"	3/4"	1"
WEIGHT LBS.	4.0	4.2	3.8	7.2

500P Series

With prongs for supporting the yoke on pipe stakes when yoke setting is connected to plastic tubing.



CATALOG No.	Y501P	Y502P	Y503P	Y504P
METER SIZE	5/8"	5/8"x3/4"	3/4"	1"
WEIGHT LBS.	4.0	4.7	4.5	7.3

200 Series

With integral outlet FIP threads.



CATALOG No.	Y201	Y202
METER SIZE	5/8"	5/8"x3/4"
WEIGHT LBS.	3.9	4.6

EC-23-NL Standard Expansion Connection Handwheel Type



EC-23W-NL Expansion Connection Wrench Type

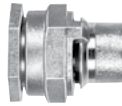

EC-23-OR-H2-NL Expansion Connection With Cartridge Dual Check Valve



ECL-23-OR-H2-SSF-NL Locking Expansion Connection With Security Screw and Dual Check Valve



Expansion Connections

CATALOG NUMBER	SIZE & TYPE	METER SIZE	APPROX. WT. LBS.
EC-1-NL	5/8" Standard	5/8"	0.7
EC-1W-NL	5/8" Wrench Type	5/8"	0.6
EC-23-NL	3/4" Standard	5/8"x3/4" & 3/4"	0.9
EC-23W-NL	3/4" Wrench Type	5/8"x3/4" & 3/4"	0.8
EC-4-NL	1" Standard	1"	1.6

ECL-23-NL Locking Expansion Connection Without Security Screw



ECL-23-SSF-NL Locking Expansion Connection With Security Screw



Locking Expansion Connections

(Available on Handwheel Type Only)

CATALOG NUMBER	DESCRIPTION	METER SIZE	APPROX. WT. LBS.
ECL-1-NL	Locking handwheel type Expansion Connection less security screw	5/8"	0.7
ECL-1-SSF-NL	Locking handwheel type Expansion Connection with security screw	5/8"	0.7
ECL-23-NL	Locking handwheel type Expansion Connection less security screw	5/8"x3/4" & 3/4"	0.9
ECL-23-SSF-NL	Locking handwheel type Expansion Connection with security screw	5/8"x3/4" & 3/4"	0.9
ECL-4-NL	Locking handwheel type Expansion Connection less security screw	1"	2.0
ECL-4-SSF-NL	Locking handwheel type Expansion Connection with security screw	1"	2.0
BOLT-800998-SSF	Security screw (fits all sizes)	-	0.005
KEY-800999-SSF	Security screw access tool	-	0.25
NUT-DR-040072-SSF	Magnetic Handle only for Expansion Connection Access Tool (excludes access tool)	-	0.25

Expansion Connections with Cartridge Check Valve(s)

CATALOG NUMBER	DESCRIPTION	METER SIZE	APPROX. WT. LBS.
EC-1-OR-H2-NL	Handwheel type Expansion Connection with dual cartridge check valves	5/8"	0.7
EC-23-OR-H2-NL	Handwheel type Expansion Connection with cartridge dual check valves	5/8"x3/4" & 3/4"	1.0
EC-4-H1-NL	Handwheel type Expansion Connection with single cartridge check valves	1"	1.8

Locking Expansion Connections

CATALOG NUMBER	DESCRIPTION	METER SIZE	APPROX. WT. LBS.
ECL-1-OR-H2-NL	Locking handwheel type Expansion Connection less security screw with dual cartridge check valves	5/8"	0.9
ECL-1-OR-H2-SSF-NL	Locking handwheel type Expansion Connection with security screw with dual cartridge check valves	5/8"	0.9
ECL-23-OR-H2-NL	Locking handwheel type Expansion Connection less security screw with dual check valves	5/8"x3/4" & 3/4"	1.3
ECL-23-OR-H2-SSF-NL	Locking handwheel type Expansion Connection with security screw with dual check valves	5/8"x3/4" & 3/4"	1.3
ECL-4-H1-NL	Locking handwheel type Expansion Connection less security screw with single cartridge check valves	1"	2.0
ECL-4-H1-SSF-NL	Locking handwheel type Expansion Connection with security screw with single cartridge check valves	1"	2.0
BOLT-800998-SSF	Security screw (fits all sizes)	-	0.005
KEY-800999-SSF	Security screw access tool	-	0.25
NUT-DR-040072-SSF	Magnetic Handle only for Expansion Connection Access Tool (excludes access tool)	-	0.25

Note: Rubber Yoke End Gaskets included

Note: Check Valves require suitable inspection and maintenance for continued operation.

Parties responsible for monitoring and maintaining proper water system design must exercise full responsibility in understanding and upholding the full intent and scope of applicable lead laws.

Ford Angle Yoke Valves

Angle Yoke Ball Valves

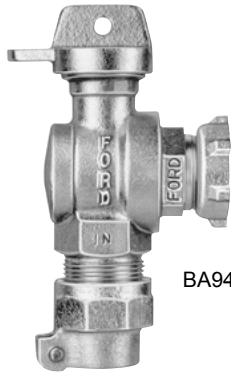

BA94-323W-NL

CATALOG NO. w/ PAD WINGS	VALVE SIZE	SERVICE LINE SIZE & TYPE	METER SIZE	APPROX. WT. LBS.
FEMALE IRON PIPE BY METER YOKE NOSE				
BA91-213W-NL	5/8"	3/4" FIP	5/8"	1.2
BA91-223W-NL	5/8"	3/4" FIP	5/8"x3/4" & 3/4"	1.2
BA91-313W-NL	3/4"	3/4" FIP	5/8"	2.0
BA91-323W-NL	3/4"	3/4" FIP	5/8"x3/4" & 3/4"	2.0
BA91-344W-NL	3/4"	1" FIP	1"	2.3
BA91-444W-NL	1"	1" FIP	1"	-
FLARED COPPER BY METER YOKE NOSE				
BA92-213W-NL	5/8"	3/4" fl. cop.	5/8"	1.6
BA92-223W-NL	5/8"	3/4" fl. cop.	5/8"x3/4" & 3/4"	1.6
BA92-313W-NL	3/4"	3/4" fl. cop.	5/8"	2.3
BA92-323W-NL	3/4"	3/4" fl. cop.	5/8"x3/4" & 3/4"	2.3
BA92-344W-NL	3/4"	1" fl. cop.	1"	-
BA92-444W-NL	1"	1" fl. cop.	1"	3.7
PACK JOINT FOR TUBING (CTS)* BY METER YOKE NOSE				
▶♦ BA94-213W-NL	5/8"	3/4" P.J./CTS	5/8"	1.5
▶♦ BA94-223W-NL	5/8"	3/4" P.J./CTS	5/8"x3/4" & 3/4"	1.5
▶♦ BA94-313W-NL	3/4"	3/4" P.J./CTS	5/8"	2.2
▶♦ BA94-323W-NL	3/4"	3/4" P.J./CTS	5/8"x3/4" & 3/4"	2.2
▶♦ BA94-324W-NL	3/4"	1" P.J./CTS	5/8"x3/4" & 3/4"	-
▶♦ BA94-344W-NL	3/4"	1" P.J./CTS	1"	2.7
▶♦ BA94-444W-NL	1"	1" P.J./CTS	1"	-
PACK JOINT FOR PIPE (PEP)* BY METER YOKE NOSE				
▶ BA96-313W-NL	3/4"	3/4" P.J./PEP	5/8"	2.3
▶ BA96-323W-NL	3/4"	3/4" P.J./PEP	5/8"x3/4" & 3/4"	2.3
▶ BA96-444W-NL	1"	1" P.J./PEP	1"	3.8

* Grip Joint for CTS and PEP is available. See options for ordering information.

▶ Ultra-Tite compression available. Add "-U-AWT" to the catalog number. (Consists of components assembled watertight.)

♦ Quick Joint is available. Add "-Q" to the catalog number.

Standard tee-head turns to 90° only. Full 360° motion of tee-head is available at a slight additional cost if specified. Add "R" to catalog number.

Example: BA91-313WR-NL

Angle Yoke Key Valves



AV91-323W-NL

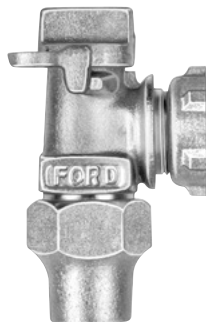

AV92-323W-NL

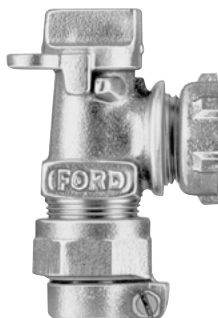

AV94-323W-NL

CATALOG NO. w/ PAD WINGS	CATALOG NO. w/ DRAIN VALVE	VALVE SIZE	SERVICE LINE SIZE & TYPE	METER SIZE	APPROX. WT. LBS.
FEMALE IRON PIPE BY METER YOKE NOSE					
AV91-313W-NL	AV91-313D-NL	3/4"	3/4" FIP	5/8"	1.3
AV91-323W-NL	AV91-323D-NL	3/4"	3/4" FIP	5/8"x3/4" & 3/4"	1.3
AV91-314W-NL	AV91-314D-NL	3/4"	1" FIP	5/8"	1.3
AV91-324W-NL	AV91-324D-NL	3/4"	1" FIP	5/8"x3/4" & 3/4"	1.3
AV91-444W-NL	AV91-444D-NL	1"	1" FIP	1"	2.0
** AV91-445-NL	AV91-445D-NL	1"	1-1/4" FIP	1"	2.7
FLARED COPPER BY METER YOKE NOSE					
AV92-313W-NL	AV92-313D-NL	3/4"	3/4" fl. cop.	5/8"	1.6
AV92-323W-NL	AV92-323D-NL	3/4"	3/4" fl. cop.	5/8"x3/4" & 3/4"	1.6
AV92-314W-NL	AV92-314D-NL	3/4"	1" fl. cop.	5/8"	2.0
AV92-324W-NL	AV92-324D-NL	3/4"	1" fl. cop.	5/8"x3/4" & 3/4"	2.0
AV92-444W-NL	AV92-444D-NL	1"	1" fl. cop.	1"	2.6
PACK JOINT FOR TUBING (CTS)* BY METER YOKE NOSE					
▶♦ AV94-313W-NL	AV94-313D-NL	3/4"	3/4" P.J./CTS	5/8"	1.5
▶♦ AV94-323W-NL	AV94-323D-NL	3/4"	3/4" P.J./CTS	5/8"x3/4" & 3/4"	1.5
▶♦ AV94-314W-NL	AV94-314D-NL	3/4"	1" P.J./CTS	5/8"	1.5
▶♦ AV94-324W-NL	AV94-324D-NL	3/4"	1" P.J./CTS	5/8"x3/4" & 3/4"	1.5
▶♦ AV94-444W-NL	AV94-444D-NL	1"	1" P.J. CTS	1"	2.3
PACK JOINT FOR PIPE (PEP)* BY METER YOKE NOSE					
▶ AV96-313W-NL	AV96-313D-NL	3/4"	3/4" P.J./PEP	5/8"	1.7
▶ AV96-323W-NL	AV96-323D-NL	3/4"	3/4" P.J./PEP	5/8"x3/4" & 3/4"	1.7
▶ AV96-444W-NL	-	1"	1" P.J./PEP	1"	2.7
PACK JOINT FOR PIPE PVC BY METER YOKE NOSE					
AV97-313W-NL	-	3/4"	3/4" P.J./PVC	5/8"	1.8
AV97-323W-NL	-	3/4"	3/4" P.J./PVC	5/8"x3/4" & 3/4"	1.8

NOTE: Ford Pack Joints for PVC are recommended for use only with Schedule 40 and Schedule 80 PVC.

* Grip Joint for CTS and PEP is available. Add "-G" to the end of catalog number.

** Indicates padlock wing not available.

♦ Quick Joint is available. Add "-Q" to the catalog number.

▶ Ultra-Tite compression available. Add "-U-AWT" to the catalog number. (Consists of components assembled watertight.)

Ford Angle and Straight Yoke Valves

Angle Yoke Compression Valves



GA94-323-NL

CATALOG NUMBER	VALVE SIZE	SERVICE LINE SIZE & TYPE	METER SIZE	APPROX. WT. LBS.
FEMALE IRON PIPE BY METER YOKE NOSE				
GA91-313-NL	3/4"	3/4" FIP	5/8"	1.5
GA91-323-NL	3/4"	3/4" FIP	5/8"x3/4" & 3/4"	1.5
GA91-314-NL	3/4"	1" FIP	5/8"	1.6
GA91-324-NL	3/4"	1" FIP	5/8"x3/4" & 3/4"	1.6
GA91-444-NL	1"	1" FIP	1"	2.2
FLARED COPPER BY METER YOKE NOSE				
GA92-313-NL	3/4"	3/4" fl. cop.	5/8"	1.8
GA92-323-NL	3/4"	3/4" fl. cop.	5/8"x3/4" & 3/4"	1.8
GA92-444-NL	1"	1" fl. cop.	1"	3.0
PACK JOINT FOR TUBING (CTS)* BY METER YOKE NOSE				
▶ GA94-313-NL	3/4"	3/4" P.J./CTS	5/8"	1.7
▶ GA94-323-NL	3/4"	3/4" P.J./CTS	5/8"x3/4" & 3/4"	1.7
▶ GA94-444-NL	1"	1" P.J./CTS	1"	2.9

* Grip Joint for CTS and PEP is available. Add "-G" to the catalog number.

NOTE: Compression valves are not available with padlock wings or drain/test valve options.

▶ Ultra-Tite compression available. Add "-U-AWT" to the catalog number. (Consists of components assembled watertight.)

Straight Yoke Ball Valves



B92-323W-NL

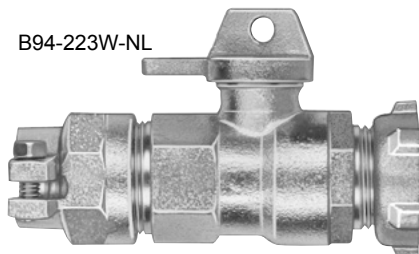

B94-223W-NL

CATALOG No. W/ PAD WINGS	CATALOG No. W/ DRAIN VALVE	VALVE SIZE	SERVICE LINE SIZE & TYPE	METER SIZE	APPROX. WT. LBS.
FEMALE IRON PIPE BY METER YOKE NOSE					
B91-213W-NL	B91-213D-NL	5/8"	3/4" FIP	5/8"	1.2
B91-223W-NL	B91-223D-NL	5/8"	3/4" FIP	5/8"x3/4" & 3/4"	1.2
B91-313W-NL	-	3/4"	3/4" FIP	5/8"	1.8
B91-323W-NL	-	3/4"	3/4" FIP	5/8"x3/4" & 3/4"	1.8
B91-314W-NL	-	3/4"	1" FIP	5/8"	1.9
B91-324W-NL	-	3/4"	1" FIP	5/8"x3/4" & 3/4"	1.9
B91-344W-NL	-	3/4"	1" FIP	1"	2.4
FLARED COPPER BY METER YOKE NOSE					
B92-213W-NL	B92-213D-NL	5/8"	3/4" fl. cop.	5/8"	1.6
B92-223W-NL	B92-223D-NL	5/8"	3/4" fl. cop.	5/8"x3/4" & 3/4"	1.6
B92-313W-NL	-	3/4"	3/4" fl. cop.	5/8"	2.6
B92-323W-NL	-	3/4"	3/4" fl. cop.	5/8"x3/4" & 3/4"	2.6
B92-314W-NL	-	3/4"	1" fl. cop.	5/8"	2.8
B92-324W-NL	-	3/4"	1" fl. cop.	5/8"x3/4" & 3/4"	2.8
B92-344W-NL	-	3/4"	1" fl. cop.	1"	3.3
PACK JOINT FOR TUBING (CTS)* BY METER YOKE NOSE					
▶♦ B94-213W-NL	B94-213D-NL	5/8"	3/4" P.J./CTS	5/8"	1.6
▶♦ B94-223W-NL	B94-223D-NL	5/8"	3/4" P.J./CTS	5/8"x3/4" & 3/4"	1.6
▶ B94-313W-NL	-	3/4"	3/4" P.J./CTS	5/8"	2.2
▶♦ B94-323W-NL	-	3/4"	3/4" P.J./CTS	5/8"x3/4" & 3/4"	2.2
▶♦ B94-314W-NL	-	3/4"	1" P.J./CTS	5/8"	2.4
▶♦ B94-324W-NL	-	3/4"	1" P.J./CTS	5/8"x3/4" & 3/4"	2.4
▶♦ B94-344W-NL	-	3/4"	1" P.J./CTS	1"	3.3
PACK JOINT FOR PIPE (PEP)* BY METER YOKE NOSE					
▶ B96-213W-NL	-	5/8"	3/4" P.J./PEP	5/8"	2.3
▶ B96-223W-NL	-	5/8"	3/4" P.J./PEP	5/8"x3/4" & 3/4"	2.3
▶ B96-313W-NL	-	3/4"	3/4" P.J./PEP	5/8"	2.9
▶ B96-323W-NL	-	3/4"	3/4" P.J./PEP	5/8"x3/4" & 3/4"	2.9
▶ B96-314W-NL	-	3/4"	1" P.J./PEP	5/8"	-
▶ B96-324W-NL	-	3/4"	1" P.J./PEP	5/8"x3/4" & 3/4"	-
▶ B96-344W-NL	-	3/4"	1" P.J./PEP	1"	-
PACK JOINT FOR PVC PIPE BY METER YOKE NOSE					
B97-213W-NL	-	5/8"	3/4" P.J./PVC	5/8"	2.3
B97-223W-NL	-	5/8"	3/4" P.J./PVC	5/8"x3/4" & 3/4"	2.3

NOTE: Ford Pack Joints for PVC are recommended for use only with Schedule 40 and Schedule 80 PVC.

Options Available

* Grip Joint for CTS and PEP is available. Add "-G" to the catalog number.

♦ Quick Joint is available. Add "-Q" to the catalog number.

▶ Ultra-Tite compression available. Add "-U-AWT" to the catalog number. (Consists of components assembled watertight.)

Tee-head stops in body permit 90° turn only. Full 360° motion of tee-head is available at a slight additional cost if specified.

Add "R" to catalog number. Example: B91-213WR-NL.

Ford Yoke Couplings and Ells

Straight Yoke Outlet Pieces

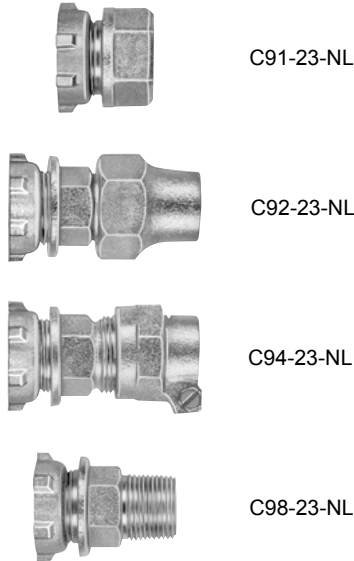

CATALOG NUMBER	METER SIZE	SERVICE LINE SIZE & TYPE	APPROX. WT. LBS.
METER YOKE NOSE BY FEMALE IRON PIPE			
Δ C91-13-NL	5/8"	3/4" FIP	0.6
C91-14-NL	5/8"	1" FIP	0.6
Δ C91-23-NL	5/8"x3/4" & 3/4"	3/4" FIP	0.6
C91-24-NL	5/8"x3/4" & 3/4"	1" FIP	0.6
Δ C91-44-NL	1"	1" FIP	0.9
C91-45-NL	1"	1-1/4" FIP	1.2
METER YOKE NOSE BY FLARED COPPER			
C92-11-NL	5/8"	1/2" fl. cop.	0.6
C92-13-NL	5/8"	3/4" fl. cop.	0.8
C92-21-NL	5/8"x3/4" & 3/4"	1/2" fl. cop.	0.6
C92-23-NL	5/8"x3/4" & 3/4"	3/4" fl. cop.	0.9
C92-44-NL	1"	1" fl. cop.	1.2
METER YOKE NOSE BY PACK JOINT FOR TUBING (CTS)*			
▶♦ C94-13-NL	5/8"	3/4" P.J./CTS	0.8
▶♦ C94-23-NL	5/8"x3/4" & 3/4"	3/4" P.J./CTS	0.8
▶ C94-44-NL	1"	1" P.J./CTS	1.2
METER YOKE NOSE BY MALE IRON PIPE			
C98-13-NL	5/8"	3/4" MIP	0.6
C98-23-NL	5/8"x3/4" & 3/4"	3/4" MIP	0.6
** C98-44-AWT-NL	1"	1" MIP	1.0

* Grip Joint for CTS is available. Add "-G" to the catalog number.

** NOTE: This item is two pieces assembled watertight.

♦ Quick Joint is available. Add "-Q" to the catalog number.

Δ Drain or Test Valve available, add "D" to catalog number.
Example: C91-13D-NL.

Yoke Ells



CATALOG NUMBER	SERVICE LINE SIZE & TYPE	METER SIZE	APPROX. WT. LBS.
FEMALE IRON PIPE BY METER YOKE NOSE			
↑Δ L91-13-NL	3/4" FIP	5/8"	0.8
↑Δ L91-23-NL	3/4" FIP	5/8"x3/4" & 3/4"	0.8
↑Δ L91-14-NL	1" FIP	5/8"	0.9
↑Δ L91-24-NL	1" FIP	5/8"x3/4" & 3/4"	0.9
↑Δ L91-44-NL	1" FIP	1"	1.3
L91-45-NL	1-1/4" FIP	1"	1.5
FLARED COPPER BY METER YOKE NOSE			
↑Δ L92-13-NL	3/4" fl. cop.	5/8"	1.0
Δ L92-14-NL	1" fl. cop.	5/8"	1.4
↑Δ L92-23-NL	3/4" fl. cop.	5/8"x3/4" & 3/4"	1.0
Δ L92-24-NL	1" fl. cop.	5/8"x3/4" & 3/4"	1.4
Δ L92-44-NL	1" fl. cop.	1"	1.8
PACK JOINT FOR TUBING (CTS)* BY METER YOKE NOSE			
▶♦↑Δ L94-13-NL	3/4" P.J./CTS	5/8"	0.8
▶♦↑Δ L94-23-NL	3/4" P.J./CTS	5/8"x3/4" & 3/4"	0.8
▶ Δ L94-14-NL	1" P.J./CTS	5/8"	1.3
▶ Δ L94-24-NL	1" P.J./CTS	5/8"x3/4" & 3/4"	1.3
▶ ↑Δ L94-44-NL	1" P.J./CTS	1"	1.7
PACK JOINT FOR PIPE (PEP)* BY METER YOKE NOSE			
▶ Δ L96-13-NL	3/4" P.J./PEP	5/8"	1.3
▶ Δ L96-23-NL	3/4" P.J./PEP	5/8"x3/4" & 3/4"	1.3
▶ L96-24-NL	1" P.J./PEP	5/8"x3/4" & 3/4"	1.3
▶ L96-44-NL	1" P.J./PEP	1"	2.0
PACK JOINT FOR PVC PIPE BY METER YOKE NOSE			
Δ L97-13-NL	3/4"	5/8"	1.3
Δ L97-23-NL	3/4"	5/8"x3/4" & 3/4"	1.3

NOTE: Ford Pack Joints for PVC are recommended for use only with Schedule 40 and Schedule 80 PVC.

Options Available

* Grip Joint for CTS and PEP is available. Add "-G" to the catalog number.

♦ Quick Joint is available. Add "-Q" to the catalog number.

▶ Ultra-Tite compression available. Add "-U-AWT" to the catalog number. (Consists of components assembled watertight.)

Δ Drain or Test Valve available, add "D" to catalog number. Example: L92-13D-NL.

↑ Drain or Test Valve on top available, add "TD" to catalog number. Example: L92-13TD-NL.

Ford Yoke Check Valves

Cartridge Style Angle Dual Check Valves



HHCA91-323-NL

CATALOG NUMBER	VALVE SIZE	METER INLET SIZE	OUTLET SIZE AND TYPE	APPROX. WT. LBS.
METER YOKE NOSE INLET BY FEMALE IRON PIPE OUTLET				
‡ ↑ HHCA91-313-NL	3/4"	5/8"	3/4" FIP	1.7
‡ ↑ HHCA91-323-NL	3/4"	5/8"x3/4" & 3/4"	3/4" FIP	1.7
‡ ↑ HHCA91-324-NL	3/4"	5/8"x3/4" & 3/4"	1" FIP	1.9
‡ ↑ HHCA91-344-NL	3/4"	1"	1" FIP	2.1
‡ ↑ HHCA91-444-NL	1"	1"	1" FIP	3.1
METER YOKE NOSE INLET BY FLARED COPPER OUTLET				
‡ ↑ HHCA92-313-NL	3/4"	5/8"	3/4" fl. cop.	2.2
‡ ↑ HHCA92-323-NL	3/4"	5/8"x3/4" & 3/4"	3/4" fl. cop.	2.2
‡ ↑ HHCA92-424-NL	1"	5/8"x3/4" & 3/4"	1" fl. cop.	3.9
‡ ↑ HHCA92-444-NL	1"	1"	1" fl. cop.	3.9
METER YOKE NOSE INLET BY PACK JOINT* OUTLET				
‡ ▶ ↑ ♦ HHCA94-313-NL	3/4"	5/8"	3/4" P.J./CTS	2.1
‡ ▶ ↑ ♦ HHCA94-323-NL	3/4"	5/8"x3/4" & 3/4"	3/4" P.J./CTS	2.1
‡ ▶ ↑ ♦ HHCA94-324-NL	3/4"	5/8"x3/4" & 3/4"	1" P.J./CTS	2.1
‡ ▶ ↑ HHCA94-414-NL	1"	5/8"	1" P.J./CTS	3.3
‡ ▶ ↑ HHCA94-424-NL	1"	5/8"x3/4" & 3/4"	1" P.J./CTS	3.4
‡ ▶ ↑ ♦ HHCA94-444-NL	1"	1"	1" P.J./CTS	3.8

Cartridge Style Straight Dual Check Valves



HHCH91-323-NL

CATALOG NUMBER	VALVE SIZE	METER INLET SIZE	OUTLET SIZE AND TYPE	APPROX. WT. LBS.
METER YOKE NOSE INLET BY FEMALE IRON PIPE OUTLET				
‡ ↑ HHCH91-313-NL	3/4"	5/8"	3/4" FIP	1.9
‡ ↑ HHCH91-323-NL	3/4"	5/8"x3/4" & 3/4"	3/4" FIP	1.9

Angle Dual Check Valves

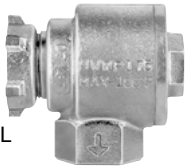

HHA91-323-NL

CATALOG NUMBER	VALVE SIZE	METER INLET SIZE	OUTLET SIZE AND TYPE	APPROX. WT. LBS.
METER YOKE NOSE INLET BY FEMALE IRON PIPE OUTLET				
Δ HHA91-313-NL	3/4"	5/8"	3/4" FIP	1.5
Δ HHA91-323-NL	3/4"	5/8"x3/4" & 3/4"	3/4" FIP	1.5
Δ HHA91-344-NL	3/4"	1"	1" FIP	2.1
METER YOKE NOSE INLET BY FLARED COPPER OUTLET				
Δ HHA92-313-NL	3/4"	5/8"	3/4" fl. cop.	2.1
Δ HHA92-323-NL	3/4"	5/8"x3/4" & 3/4"	3/4" fl. cop.	2.1
METER YOKE NOSE INLET BY PACK JOINT* OUTLET				
▶ Δ HHA94-313-NL	3/4"	5/8"	3/4" P.J./CTS	2.0
▶ Δ ♦ HHA94-323-NL	3/4"	5/8"x3/4" & 3/4"	3/4" P.J./CTS	2.0
▶ Δ HHA96-323-NL	3/4"	5/8"x3/4" & 3/4"	3/4" P.J./PEP	2.0

Straight Dual Check Valves



HHS91-323-NL

CATALOG NUMBER	VALVE SIZE	METER INLET SIZE	OUTLET SIZE AND TYPE	APPROX. WT. LBS.
METER YOKE NOSE INLET BY FEMALE IRON PIPE OUTLET				
HHS91-313-NL	3/4"	5/8"	3/4" FIP	1.9
HHS91-323-NL	3/4"	5/8"x3/4" & 3/4"	3/4" FIP	1.9
HHS91-344-NL	3/4"	1"	1" FIP	2.4

Angle Check Valves for Yokes

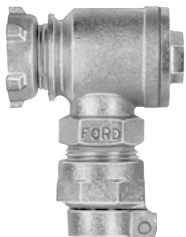

HA94-323-NL

CATALOG NUMBER	VALVE SIZE	METER INLET SIZE	OUTLET SIZE AND TYPE	APPROX. WT. LBS.
METER YOKE NOSE INLET BY FEMALE IRON PIPE OUTLET				
Δ HA91-313-NL	3/4"	5/8"	3/4" FIP	1.3
Δ HA91-323-NL	3/4"	5/8"x3/4" & 3/4"	3/4" FIP	1.3
Δ HA91-444-NL	3/4"	1"	1" FIP	1.8
METER YOKE NOSE INLET BY FLARED COPPER OUTLET				
Δ HA92-313-NL	3/4"	5/8"	3/4" fl. cop.	1.7
Δ HA92-323-NL	3/4"	5/8"x3/4" & 3/4"	3/4" fl. cop.	1.7
METER YOKE NOSE INLET BY PACK JOINT* OUTLET				
▶ Δ HA94-313-NL	3/4"	5/8"	3/4" P.J./CTS	1.6
▶ Δ ♦ HA94-323-NL	3/4"	5/8"x3/4" & 3/4"	3/4" P.J./CTS	1.6
▶ Δ HA94-324-NL	3/4"	5/8"x3/4" & 3/4"	1" P.J./PEP	1.6
▶ Δ HA96-313-NL	3/4"	5/8"	3/4" P.J./PEP	1.6
▶ Δ HA96-323-NL	3/4"	5/8"x3/4" & 3/4"	3/4" P.J./PEP	1.6

Options Available

* **Grip Joint for CTS and PEP** is available. Add "-G" to the catalog number. Example: HHA94-313-G-NL

♦ **Quick Joint** is available. Add "-Q" to the catalog number. Example: HHCA94-323-Q-NL

‡ Cartridges are available with enhanced chlorine/chloramines resistance. Add "CR" to the end of the alpha code. Example: HHCACR91-313-NL.

▶ **Ultra-Tite** compression available. Add "-U-AWT" to the catalog number. (Consists of components assembled watertight.)

Δ **Drain or Test Valve** available, add "D" to catalog number. Example: HHA91-313D-NL

↑ **Drain or Test Valve on top** available, add "TD" to catalog number. Example: HHCA91-313TD-NL

Ford Yoke Check Valves

Straight Check Valves for Yokes

HS91-323-NL



CATALOG NUMBER	VALVE SIZE	METER INLET SIZE	OUTLET SIZE & TYPE	APPROX. WT. LBS.
METER YOKE NOSE INLET BY FEMALE IRON PIPE OUTLET				
HS91-313-NL	3/4"	5/8"	3/4" FIP	1.3
HS91-323-NL	3/4"	5/8"x3/4" & 3/4"	3/4" FIP	1.3
HS91-444-NL	1"	1"	1" FIP	1.8

Ford Yoke Gaskets and Accessories

Rubber Yoke End Gaskets (To seal on yoke nose of yoke valves and fittings)



CATALOG NUMBER	DESCRIPTION AND USAGE				APPROX. WT. LBS.*	STD. PKG. QTY.
	GASKET SIZE	METER SIZE	I.D.	O.D.		
GT-112	5/8"	5/8"	11/16"	1-3/32"	1.9	500
GT-118	3/4"	5/8"x3/4"	13/16"	1-11/32"	2.3	400
GT-123	1"	1"	1-1/16"	1-21/32"	2.6	300

Beveled Rubber Gaskets for Expansion Connections

(To place between expansion connection thimble/nose piece and handwheel)



CATALOG NUMBER	DESCRIPTION			APPROX. WT. LBS.*	STD. PKG. QTY.
	GASKET SIZE	METER SIZE	EX CON No.		
GT-32	5/8"	5/8"	EC-1-NL	2.1	1000
GT-33	3/4"	5/8"x3/4" & 3/4"	EC-23-NL	2.2	250
GT-34	1"	1"	EC-4-NL	1.7	200

Flat Rubber Gaskets for Expansion Connections

(To place into the female meter thread end of expansion connection body)



CATALOG NUMBER	DESCRIPTION AND USAGE					APPROX. WT. LBS.*	STD. PKG. QTY.
	GASKET SIZE	METER SIZE	EX CON No.	I.D.	O.D.		
GT-210	5/8"	5/8"	EC-1-NL	11/16"	31/32"	3.0	1000
GT-196	3/4"	5/8"x3/4" & 3/4"	EC-23-NL	13/16"	1-7/32"	2.3	500
GT-211	1"	1"	EC-4-NL	1-1/8"	1-9/16"	2.8	400

*Weights for gaskets are for standard package quantities.

Lock Nuts

YLN-23



CATALOG NUMBER	METER SIZE
YLN-1	5/8"
YLN-23	5/8"x3/4" & 3/4"
YLN-4	1"

Expansion Connection Wrenches



YEW-3

CATALOG NUMBER	METER SIZE
YEW-1	5/8"
YEW-3	5/8"x3/4" & 3/4"
YEW-4	1"



YEW-4

Spanner Wrench for Lock Nuts



YSW

CATALOG NUMBER	METER/LOCK NUT SIZE
YSW	5/8" through 1"

Valve Lock Cap



BV-LOCKCAP-2

Ball Valve Lock Caps

CATALOG NUMBER	DESCRIPTION	APPROX. WT. LBS.
BV-LOCKCAP-2	Lock Cap and Pin for 5/8" Ball Valve	0.6
BV-LOCKCAP-34	Lock Cap and Pin for 5/8" BH, 3/4" and 1" Ball Valves	1.0
BV-LOCKCAP-567	Lock Cap and Pin for 1-1/4", 1-1/2" and 2" Ball Valves	1.2



KV-LOCKCAP-3

Key Valve Lock Caps

CATALOG NUMBER	DESCRIPTION	APPROX. WT. LBS.
AV-LOCKCAP-23	Lock Cap and Pin for 5/8" and 5/8"x3/4" and 3/4" Angle Key Valves	0.7
KV-LOCKCAP-3	Split Body Lock Cap and Pin for 3/4" Key Valve with Meter Nut	1.0

Section E

Ford[®] Yokes and Yoke Parts

Warranty

All merchandise is warranted to be free from defects in material and factory workmanship for one year from date of shipment from our factory. We will provide, free of charge, new products in equal quantities for any that prove defective within one year from date of shipment from our factory. Manufacturer shall not be liable for any loss, damage, or injury, direct or consequential, arising out of the use of or the inability to use the product. Before using, user shall determine the suitability of the product for user's intended use and user assumes all risk and liability whatever in connection therewith. No claims for labor or consequential damage will be allowed. The foregoing may not be changed except by agreement signed by an officer of the manufacturer.

No other warranties are applicable or may be implied, including the implied warranty of merchantability and the implied warranty of fitness for particular purpose and any warranty relating to infringement or the like, all of which are disclaimed.

Parties responsible for monitoring and maintaining proper water system design must exercise full responsibility in understanding and upholding the full intent and scope of applicable lead laws.

Please Note:

Consult The Ford Meter Box Company, Inc. website (www.fordmeterbox.com) for the most recent catalog information. The Ford Meter Box Company considers the information in this catalog to be correct at the time of publication. Items and option availability, including specifications, are subject to change without notice. Please verify that your product information is current.

 **The Ford Meter Box Co., Inc.** 775 Manchester Avenue, P.O. Box 443, Wabash, Indiana, USA 46992-0443
Telephone: 260/563-3171 FAX: 800-826-3487 Overseas FAX: 260/563-0167 www.fordmeterbox.com