

pHampler[®]

*Reactor Sampling
Monitoring & Control System*

ZERO EXPOSURE / GUARANTEED RESULTS

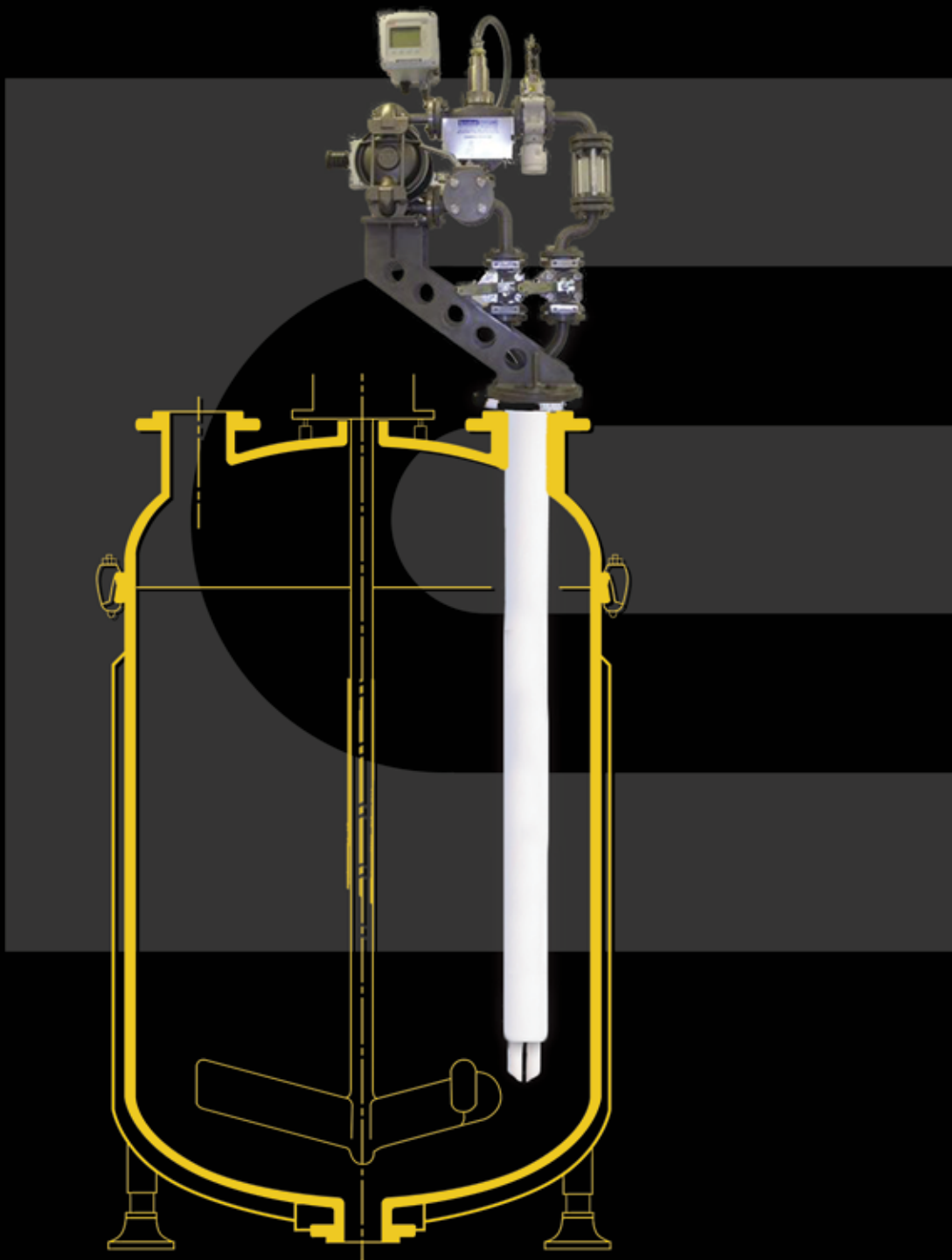

Zero Exposure, Eliminate Fugitive Emissions And Improve Yield

The pHampler® is Ethylene's patented reactor sampling and pH measurement / control system for agitated reactors. The pHampler enables the reactor manway to be kept closed during sampling and / or monitoring, eliminating fugitive emissions to dramatically improve operator and environmental safety. Yield is improved with the system's unprecedented sampling and in-line pH measurement and control flexibility.

The pHampler® dip tube is available in standard 2", 3" and 4" sizes, constructed with schedule 80 carbon steel pipe, and completely encapsulated and lined with PTFE to provide maximum chemical resistance and rigidity in hostile agitated vessels.

INTRINSICALLY
SAFE



Performance Features

Eliminate Fugitive Emissions

Unique design keeps the reactor manway closed, eliminating operator and environmental exposure to process liquid and vapor; also preventing the release of EPA regulated fugitive emissions.

Continuous Representative Sampling

The sample point - located just above the agitator blade and the high flow rate of the in-line circulation loop assures instantaneous and representative sampling accuracy.

Surfaces Wetted With PTFE

Surfaces wetted with PTFE, PFA or ETFE provide maximum corrosion protection and assure product purity. The dip tube and circulation loop can be constructed entirely from stainless steel or exotic alloys for less corrosive environments or higher temperatures.

System Design

Each pHampler is CAD designed and can be engineered to meet your specific requirements. The modular design can easily be altered to meet changing process conditions and transferred from one reactor to another.

Sample Isolation

Samples can be returned to the reactor without operator or environmental exposure, eliminating costly hazardous waste disposal.

pH Measurement and Control

Circulation loop easily accommodates an Ethylarmor® in-line pH probe for fast accurate and continuous pH measurement and control. The pH probe can be safely isolated for maintenance even in the middle of a batch.

Maximum Nozzle Availability

Each pHampler system uses only one reactor nozzle for all sampling, liquid and / or gas addition, pH measurement / control and sample return.

Increase Yield

Cycle time reductions and improved yields can pay for the pHampler system within the first few batches.

No Cross Batch Contamination

The dip tube and circulation loop are free of crevices that can contaminate high purity or sensitive batch applications. Surfaces wetted with PTFE are easily cleaned without dismantling the system.

Slurry Services

The pHampler system has a proven track record in high velocity slurry activity.

Ease of Use

All sampling, instrumentation and valves are centrally located. One operator controls all functions from a single location.

pHampler®

The pHampler is available in two designs

pHampler "VSA" - Vacuum Sampling & Addition

VSA is designed for manual sampling and liquid addition of reactors using vacuum along with Ethylene's FM approved FLO-VU® sight flow check valve.

(See page 4 & 5 for more information)

pHampler "EPL" - External Piping Loop

EPL is a continuous circulation loop that provides liquid sampling, addition, sample return, and in-line pH measurement and control.

(See page 4 & 5 for more information)



pHampler® TurnKey top-works can be designed to meet your monitoring and sampling requirements.

pHampler® head without dip pipe can be used to add nozzles on your vessel

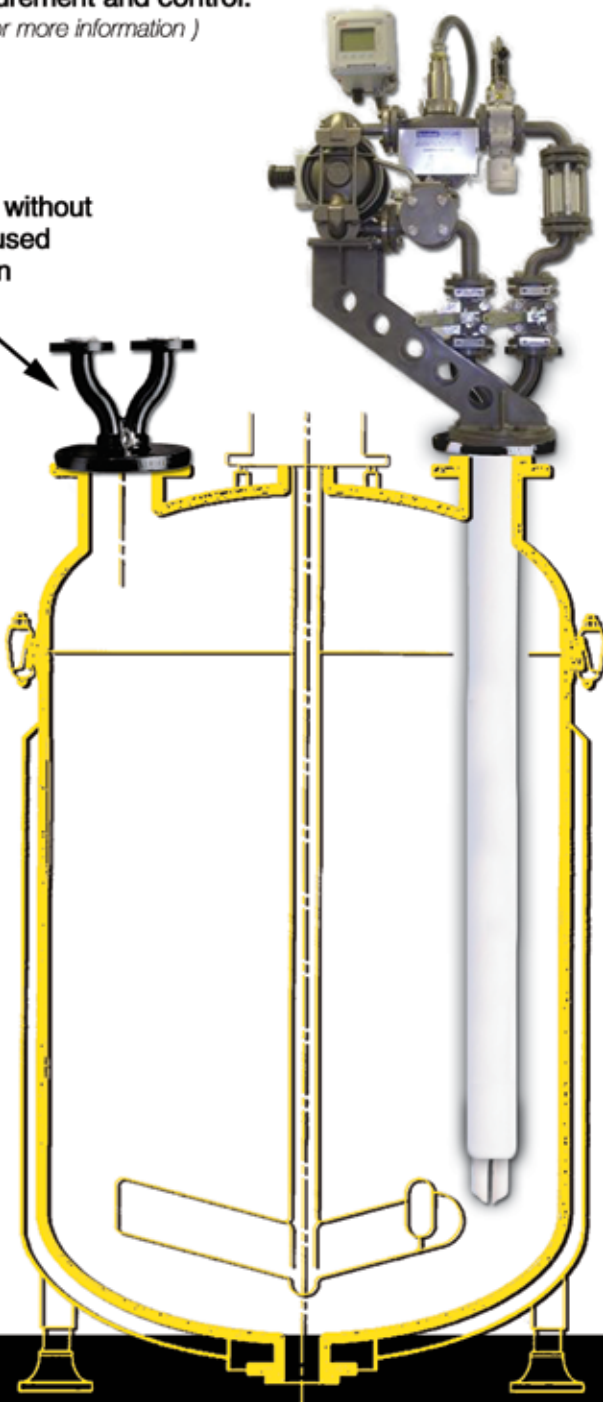

Stainless steel and exotic alloy pHampler® systems also available.

"EPL" - External Piping Loop Instrumentation System

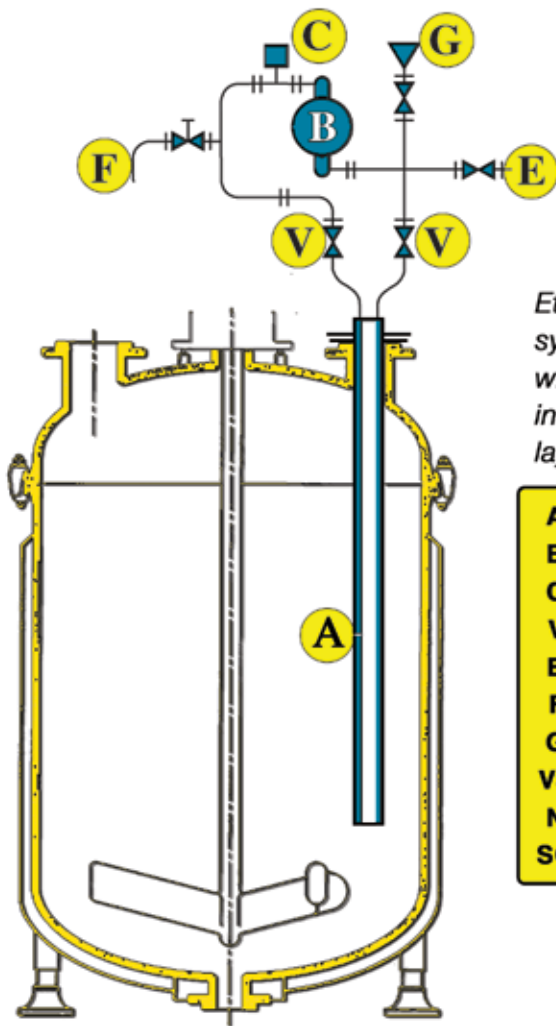

Ethylene can engineer a turn-key system to fit your specific needs with regards to pumps, valves, instrumentation and dimensional layout.

- A. pHampler Dip Tube
- B. Diaphragm Pump
- C. pH Probe with Transmitter
- V. Dip Tube Isolation Valve
- E. Liquid / Gas Addition
- F. Sample out
- G. Sample Return
- VS. To Vacuum Supply
- N. Purge
- SG. FLO-VU® Float Check Valve

The pHampler® "EPL" system consists of a continuous loop that provides liquid sampling, addition, sample returns, and in-line pH measurement and control. Liquid is pulled from the reactor and pumped through a pipe lined with PTFE, PFA or ETFE that can contain various analytical equipment, such as pH & temperature probes and ion sensors.

"VSA" - Vacuum Sampling & Vacuum Sampling System

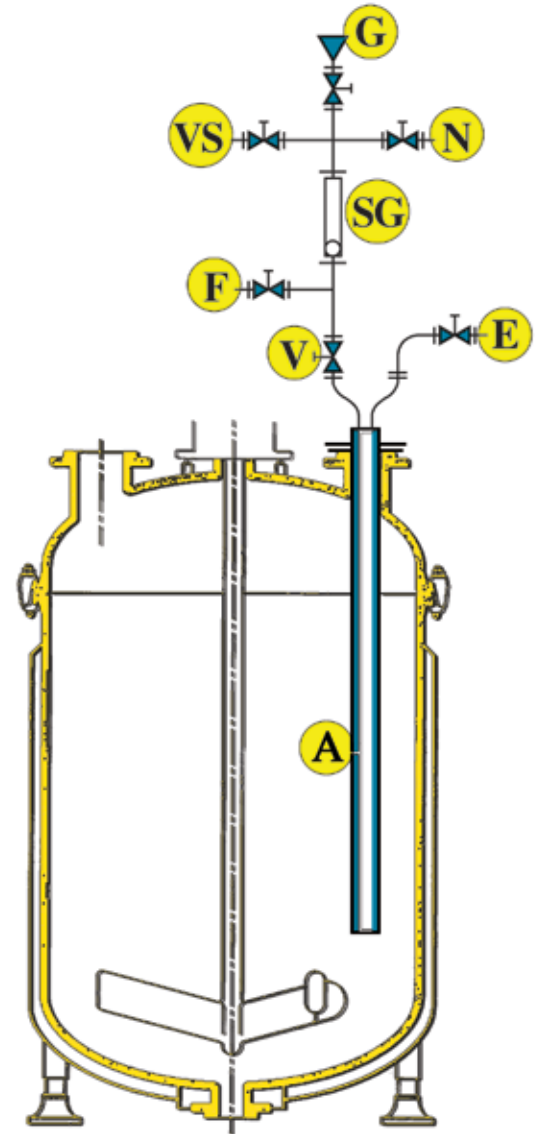

The pHampler® "VSA" system is designed for liquid addition and manual sampling of reactors using vacuum. The sample is drawn into the sample leg, then drained back into an external sampling valve. Where continuous pH measurement is not required, the "VSA" provides a safe and convenient way for liquid sampling, addition and sample return.

**Addition
em**

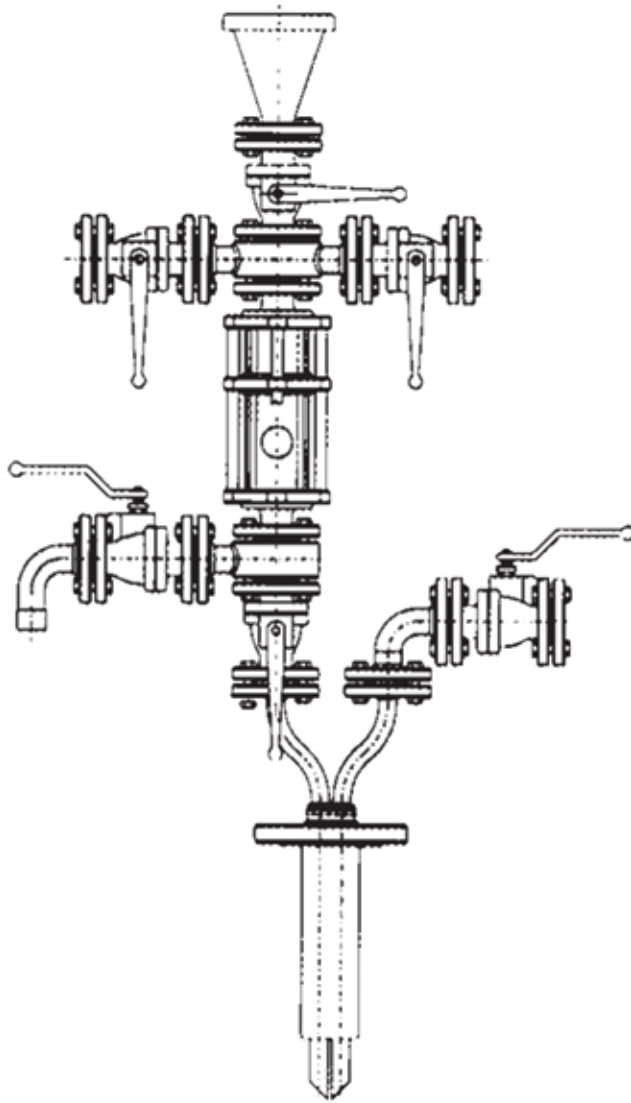

**“VSA”
TurnKey Design**

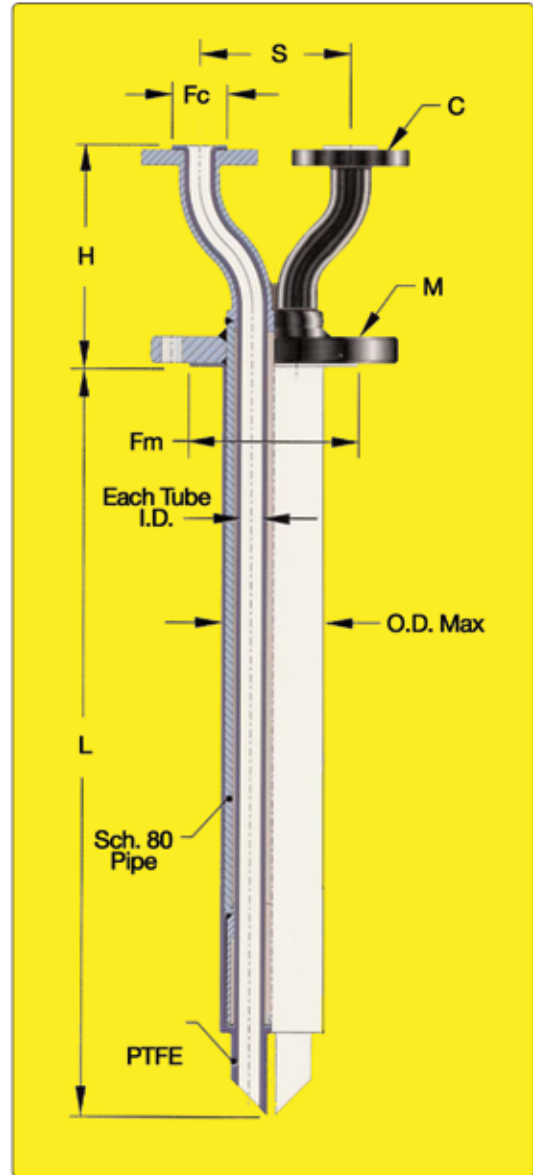

Nominal Size	PTFE Wall	Connecting Flange 'C'	Mounting Flange 'M'	PTFE Flare		S	Max. OD	Max. L	Dim. H
				F _C	F _M				
2	.125	1	3	2	5	5½	2 13/16	20'-0"	8"
3	.125	1	4	2	6 3/16	5½	3 15/16	15'-0"	8"
4	.150	1	6	2	8 ½	5½	4 15/16	15'-0"	8 ½"
6	.150	2	8	3 ¾	10 5/8	9	7 7/16	10'-0"	12"

TurnKey Systems & Data

The design of the phampler[®] reactor sampling system can be engineered to meet your exact dimensions, process conditions and component specifications. pHampler EPL systems with in-line pH measurement and control meet the requirements for Class 1, Division 1, and Group C & D service.

The three systems shown are representative of Ethylene's unique design and fabrication capability. Although both the pHampler EPL and VSA system have surfaces wetted with PTFE, PFA or ETFE, the dip tube and circulation loop can also be constructed of stainless steel or exotic alloys to meet your operational requirements and demands.

pHampler[®] Data

Pressure Range: Full vacuum to 150 psi

Temperature Range: (-)20°F to 350°F

Note: The Pressure / Temperature rating of the pHampler[®] system is a direct function of all components in the system: pump, valves, instrumentation etc.

Nozzle Requirements: The 2" pHampler[®] dip tube is designed for a 3" minimum vessel nozzle. The 3" pHampler[®] requires a 4" vessel nozzle, the 4" pHampler[®] requires a 6" vessel nozzle.

System I (Dimensions are in inches unless otherwise specified)

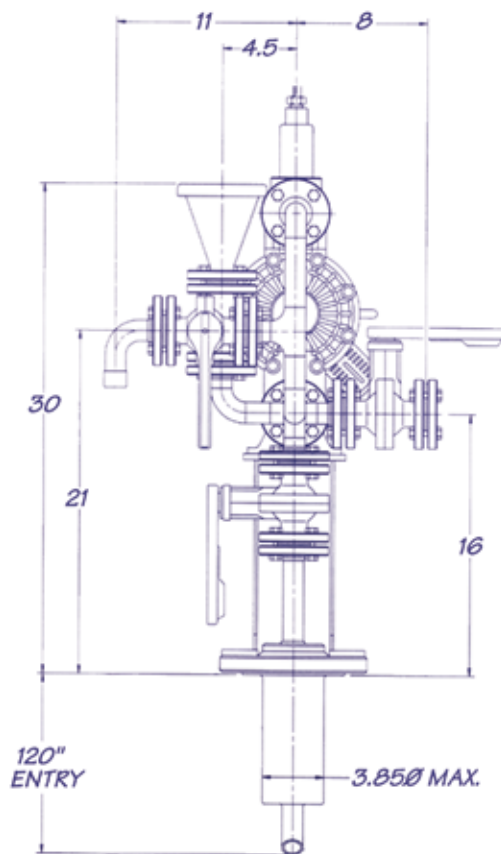
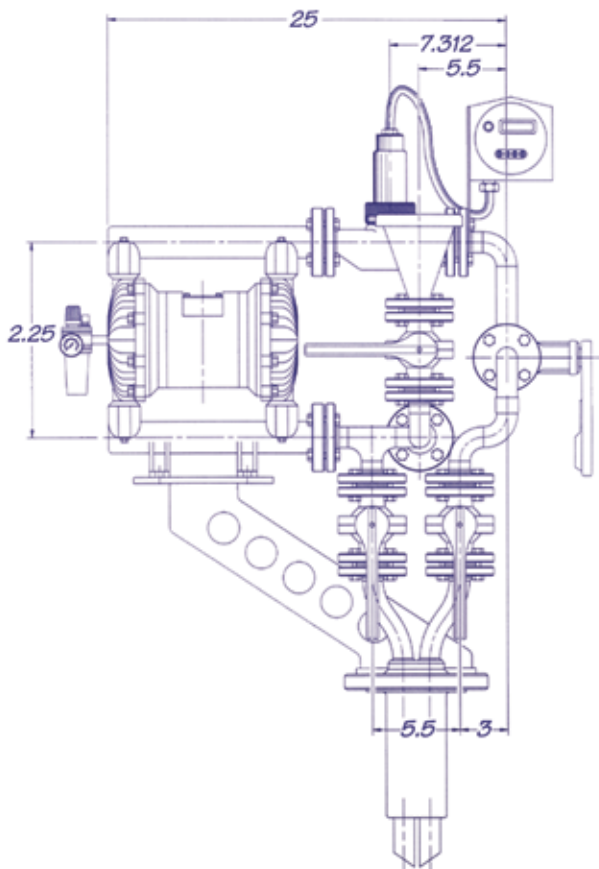

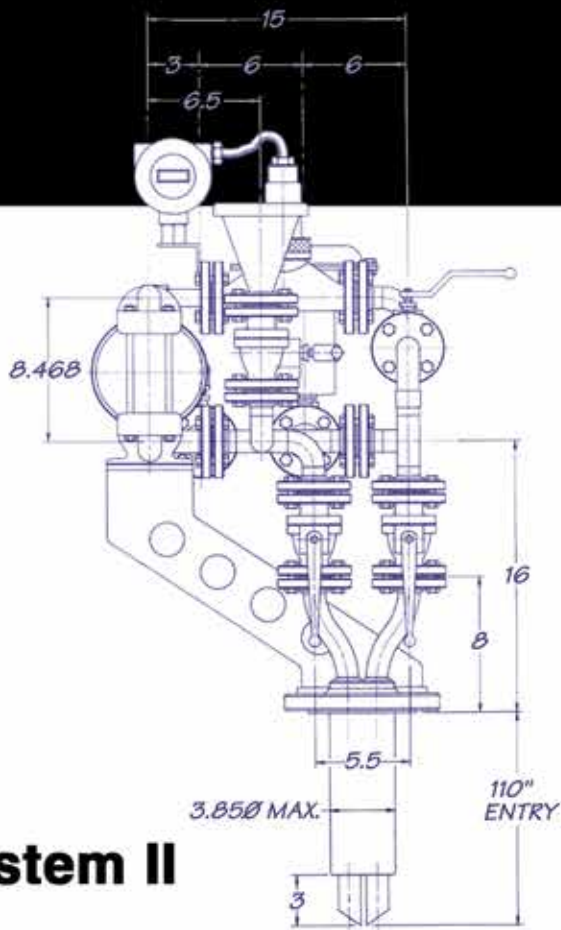

System II

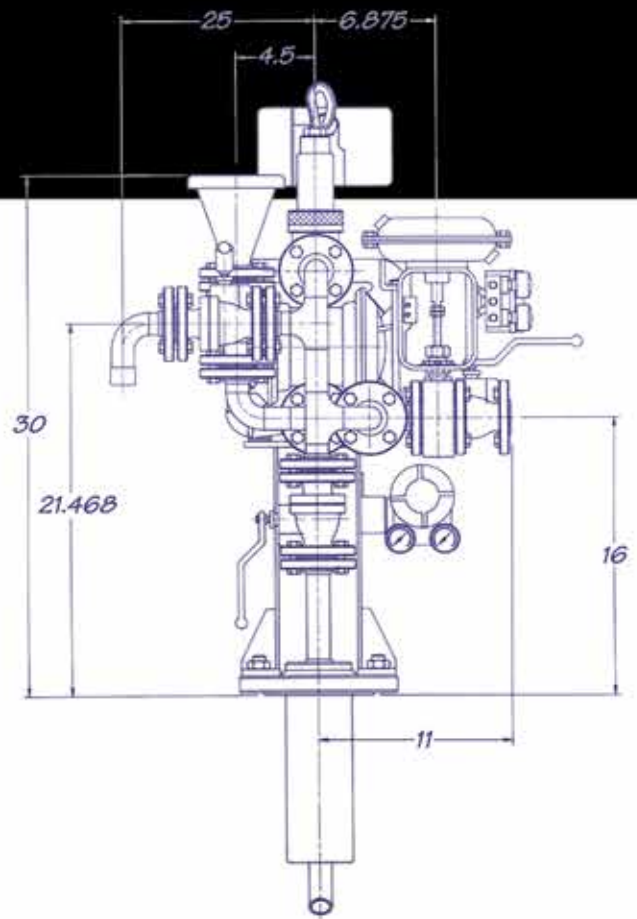

System III

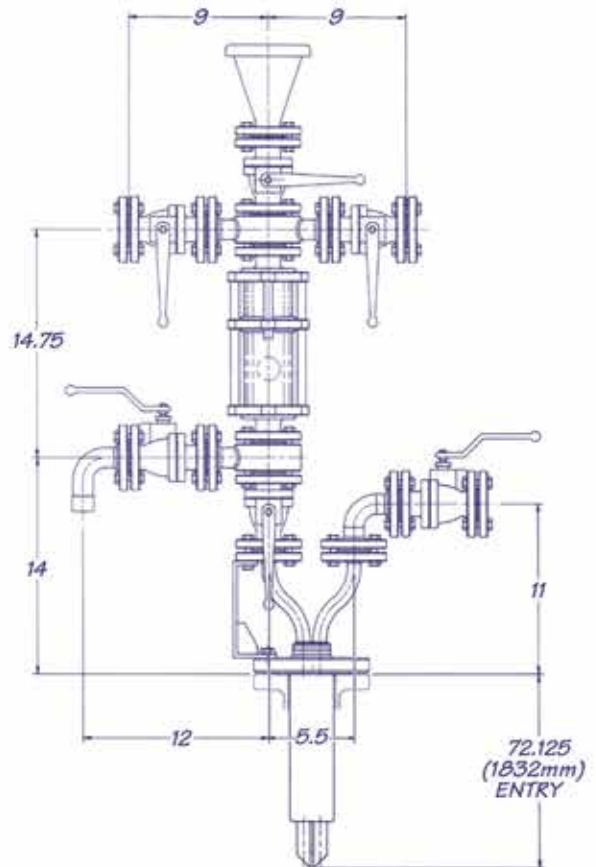
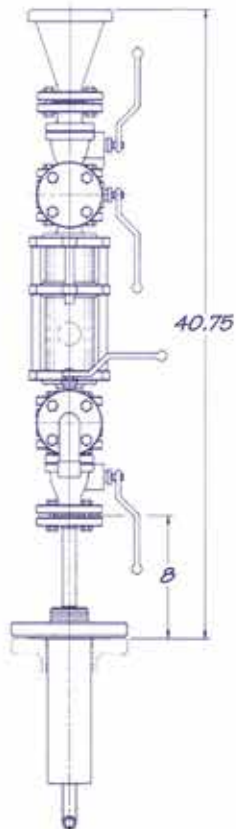

**THE WORLD LEADER IN FLUOROPOLYMER TECHNOLOGY
FOR OVER 50 YEARS**



Flexijoint® PTFE Expansion Joints

Flexijoint® is designed for severe service applications that demand consistent reliability, lower permeation rates and maximum travel. Available in sizes of 1/2" to 42" diameters with 2 to 12 convolutions to compensate for pipe movement, misalignment and/or vibration. Features include - Full vacuum resistance to 400°F, Uniformed PTFE wall thickness, T-Bands™ for convolution support and Limitlink™ axial restraints that eliminate cumbersome limit bolts. Flexijoints® low spring rate is ideal for stress-sensitive FRP piping, graphite pumps and glass lined process vessels and equipment.



FlexArmor® PTFE Lined (double contained) Bellows

FlexArmor® combines a 321 stainless steel armored bellows with a Flexijoint® heavy wall PTFE liner to provide higher pressure capability (200psi), outstanding chemical resistance and the added security of double containment. The bellows have a size range to 24" diameter and can operate at Temperatures from -40°F to +400°F. FlexArmor® bellows are designed and engineered to any specific customer requirements.

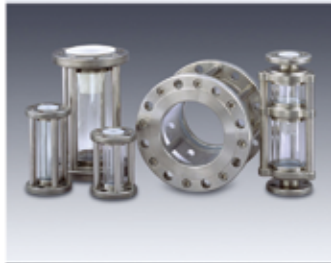

FLO-VU® Sight Indicators With Safety Shield

Ethylene's sight flow indicators incorporate energized PFA seals with a full 360° view Borosilicate glass that provides a continuous bubble-tight seal at 150psi even after repeated thermal cycling - GUARANTEED! Available in 1" to 8" diameter and lengths from 5" to 30" and can operate at temperatures of -20°F to +350°F. Also available with tri-clamp end connections and dual containment configuration.



**MonoDerm™
Large Diameter Lined Pipe and Special Shapes**

MonoDerm™ is Ethylene's trademark for its heavy duty, seamless lined piping components. Available in PTFE, PFA or ETFE with a size range from 1/2" to 42" diameter. Ethylene's isostatic molding and high capacity rotational molding cells can line virtually any configuration imaginable such as piping headers, pump casings and valves.



**EthylArmor® & pHampler®
Dip Tubes, Spargers & Sampling**

EthylArmor® is a PTFE lined and covered armored dip pipe or sparger designed exclusively for the rigorous demands of agitating vessels or the high stress of injection. Also available is Ethylene's Solid PTFE dip pipes and spargers for non-agitated services. pHampler® is a patented reactor sampling, monitoring and control system that eliminates fugitive emissions and employee exposure to hazardous media while providing guaranteed analyzed results. See picture on back for complete assembly.



T-Line Strainers™

Fully lined ETFE or PFA ductile iron strainers in sizes 3" to 8", temperatures to 450°F delivers maximum Cv's and chemical resistance while protecting your valuable downstream equipment such as lined pumps, heat exchangers and glass lined vessels.



4855 Broadmoor Ave. - Kentwood, MI 49512
Ph 616-554-0900 FAX 616-554-3464
www.ethylene.com

ETHYLENE LLC., INFORMATION IS BASED ON TECHNICAL DATA AND TESTING THAT ETHYLENE BELIEVES TO BE RELIABLE AND IS SUBJECT TO CHANGE WITHOUT NOTICE. THE INFORMATION IS INTENDED FOR USE BY PERSONS HAVING TECHNICAL SKILL, AT THEIR OWN DISCRETION AND RISK. SINCE CONDITIONS AND USE OF PRODUCTS ARE OUTSIDE OF ETHYLENE'S CONTROL, ETHYLENE LLC, MAKES NO WARRANTIES, EXPRESS OR IMPLIED AND ASSUMES NO LIABILITY IN CONNECTION WITH ANY USE OF THIS INFORMATION. ETHYLENE™, FLEXIJOINT®, FLEXARMOR®, FLO-VU®, ETHYLARMOR®, PHAMPLER®, MONODERM AND T-LINE STRAINERS ARE EITHER REGISTERED OR TRADEMARKS OF ETHYLENE LLC.

PH-03090913-02