

# NEWCO®

## Cast Steel Valves

### Technical Data

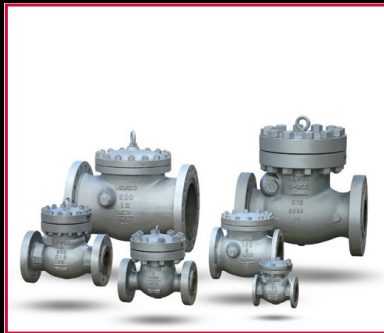

All the information contained in this manual is the exclusive property of Cameron. Any reproduction or use of the calculations, drawings, photographs, procedures or instructions, either expressed or implied, is forbidden without the written permission of Cameron or its authorized agent.

Initial Release 01  
October 2013

Produced by Technical Publications, Houston, TX, USA

© 2013 Cameron

## PREFACE

The procedures included in this book are to be performed in conjunction with the requirements and recommendations outlined in API Specifications. Any repairs to the equipment covered by this book should be done by an authorized Cameron service representative. Cameron will not be responsible for loss or expense resulting from any failure of equipment or any damage to any property or death or injury to any person resulting in whole or in part from repairs performed by anyone other than authorized Cameron personnel. Such unauthorized repairs shall also serve to terminate any contractual or other warranty, if any, on the equipment and may also result in equipment no longer meeting applicable requirements.

File copies of this manual are maintained. Revisions and/or additions will be made as deemed necessary by Cameron. The drawings in this book are not drawn to scale, but the dimensions shown are accurate.

This book covers Cameron products.

Cameron  
P.O. Box 1212  
Houston, Texas 77251-1212  
713-939-2211  
<http://www.c-a-m.com>

**NOTES:**

## TABLE OF CONTENTS

Overview.....	7
I. Cast Steel Bolted Bonnet Gate Valves..... Sizes: 2" to 48" • Pressure Class: 150 to 1500	18
II. Cast Steel Bolted Bonnet Globe Valves..... Sizes: 2" to 14" • Pressure Class: 150 to 1500	30
III. Cast Steel Bolted Bonnet Angle Valves..... Sizes: 2" to 12" • Pressure Class: 150 to 600	42
IV. Cast Steel Bolted Cover Swing Check Valves..... Sizes: 2" to 24" • Pressure Class: 150 to 1500	50
V. Cast Steel Bolted Cover Tilting Disc Check Valves..... Sizes: 2" to 12" • Pressure Class: 150 to 300 (Pressure Seal 600 to 2500)	62
VI. Cast Steel Bolted Bonnet Stop Check Valves..... Sizes: 2" to 14" • Pressure Class: 150 to 1500	68
VII. Cast Steel Bolted Bonnet Angle Stop Check Valves..... Sizes: 2" to 12" • Pressure Class: 150 to 600	80
VIII. How to Order All Cameron's NEWCO Products.....	88
IX. Industry Standards Typically Used in Valve Manufacturing.....	90

**NOTES:**

# OVERVIEW

## Valve and I.D. Tag Overview

The identification tag displays all construction and tracking data regarding the respective valve on which it is attached. Below is a general overview of the identification tag components.

I.D. tags are located in 1 of the 3 following areas:

- Yoke
- Body/Bonnet Flange
- Under The Handwheel Nut

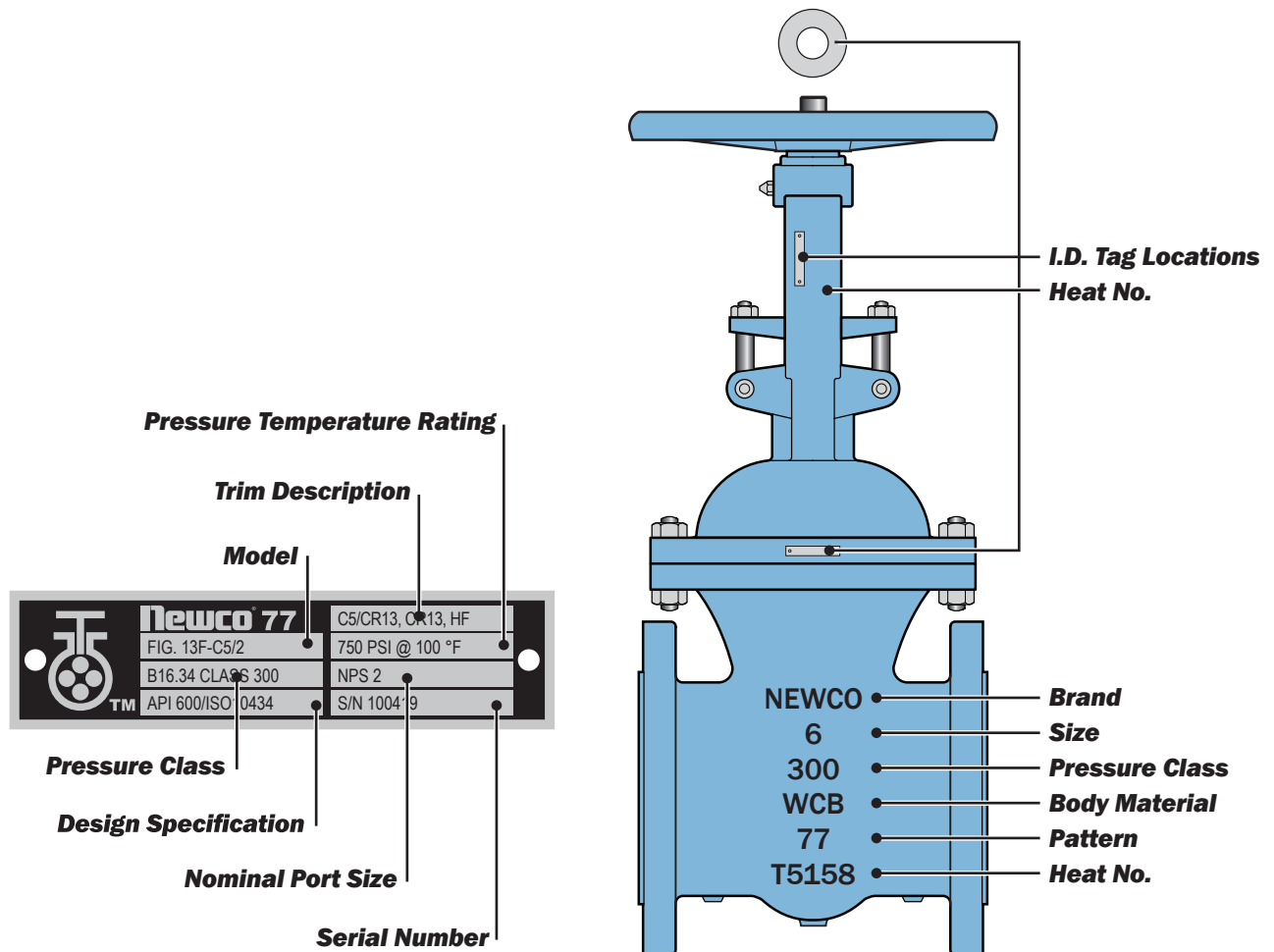

## Body/Bonnet Materials

Cameron's NEWCO® cast steel valves are available in stock in a wide range of body/bonnet materials and optional trim materials. Listed below are some of the more popular materials. Additional materials are available. Please contact Cameron or your local distributor for details.

Material Designation	Common Description	ASTM Specs.	Body/Bonnet Material Service Limitations*
CB	Carbon Steel	A216	Non-corrosive service water, oil and gases at temperatures between -20° F and +800° F.
LCC	Low Temp. Carbon	A352	Low temperature service between -50° F and +650° F.
WC6	1.25% Chrome and .5% Moly	A217	Non-corrosive service water, oil and gases at temperatures between -20° F and +1100° F.
WC9	2.25% Chrome and 1% Moly	A217	Non-corrosive service water, oil, and gases at temperatures between -20° F and +1100° F.
C5	5% Chrome and .5% Moly	A217	Corrosive, non-corrosive or erosive service at temperatures between -20° F and +1200° F.
C12	9% Chrome and 1% Moly	A217	Corrosive, non-corrosive or erosive service at temperatures between -20° F and +1200° F.
C12A	9% Chrome, 1% Moly and V	A217	Corrosive, non-corrosive or erosive service at temperatures between -20° F and +1200° F.
C8M	Cast 316	A351	Corrosive, cryogenic or high temperature service between -450° F and +1200° F.
A20	Alloy 20	A351	Corrosive service at temperatures between -20° F and +300° F.

\* Limitations are per 2004 Edition of ASME B16.34.

## Trim Materials

The following are Cameron's NEWCO standard trim designations.

Trim Number	Common Name	API 600 Trim No.	Seat Ring Facing (1)	Wedge or Disc Facing (1)	Stem	Other Trim Parts (2)	Service Limitations
1	13 Chrome	1	CR 13	CR 13	CR 13	CR 13	Non-corrosive applications. Steam, gas and general service to 700° F. Oil and oil vapor to 900° F.
2	Half Stellite	8	HF	CR 13	CR 13	CR 13	Steam, gas and general service to 1000° F. Standard trim for gate valves.
3	Full Stellite	5	HF	HF	CR 13	CR 13	Premium trim service to 1200° F. Excellent for high pressure water and steam service.
4	316	10	316	316	316	316	Corrosive services to 850° F. Low temperature service standard for 316 SS valves.



Trim Number	Common Name	API 600 Trim No.	Seat Ring Facing (1)	Wedge or Disc Facing (1)	Stem	Other Trim Parts (2)	Service Limitations
4/2	316/Half Stellite	12	HF	316	316	316	
4/3	316/Full Stellite	16	HF	HF	316	316	
5	Monel	9	NiCu	NiCu	NiCu	NiCu	Corrosive services to 750° F.
5/2	Monel/Half Stellite	11	HF	NiCu	NiCu	NiCu	
5/3	Monel/Full Stellite	-	HF	HF	NiCu	NiCu	
6	Alloy 20	13	A20	A20	A20	A20	Corrosive services to 300° F.
7	Bronze	-	BRZ	BRZ	BRZ	BRZ	Water, gas or low pressure steam to 450° F.
A7	Aluminum Bronze	-	AL BRZ	AL BRZ	AL BRZ	AL BRZ	
8	Iron	-	Iron	Iron	STL	Iron or STL	
X	Special	Special	Special	Special	Special	Special	Customer to specify.

(1) Facing is defined as the seating surface of a seat ring and wedge/disc.

(2) Other trim parts are defined as small internal parts that are normally in contact with the service fluid. This includes the stem, backseat bushing in gate and globe valves and the swing check disc nut.

### Sour Gas Service Materials

Cameron's NEWCO cast steel valves may be furnished with body and trim materials in compliance with NACE MR-01-75 specifications. The standard valve is WCB with double tempered trim 2 and Class II bolting. Other materials, trim and bolting are available.

### Features and Benefits

- Certifications
- International Organization for Standardization (ISO)
- Traceability
- Fugitive Emissions Tested
- API-598 Tested
- Major End-user Approved
- Multiple North American Locations
- Extensive Engineering Capabilities
- Excellent Customer Service
- Warranty
- Onsite Non-destructive Testing
- Field Services for Start-up
- Inhouse Automation Capabilities

Pressure Temperature Ratings - ASME B16.34 - 2004							
Class 150							
Temperature °F (°C)	WCB*	LCC	WC6	WC9	C5	C12	C12A
-20 to 100 (-29 to 38)	285	290	290	290	290	290	290
200 (93)	260	260	260	260	260	260	260
300 (148)	230	230	230	230	230	230	230
400 (204)	200	200	200	200	200	200	200
500 (260)	170	170	170	170	170	170	170
600 (316)	140	140	140	140	140	140	140
650 (343)	125	125	125	125	125	125	125
700 (371)	110	-	110	110	110	110	110
750 (399)	95	-	95	95	95	95	95
800 (427)	80	-	80	80	80	80	80
850 (454)	65	-	65	65	65	65	65
900 (482)	50	-	50	50	50	50	50
950 (510)	35	-	35	35	35	35	35
1000 (538)	20	-	20	20	20	20	20
1050 (566)	-	-	20**	20**	20**	20**	20
1100 (593)	-	-	20**	20**	20**	20**	20
1150 (621)	-	-	-	-	20**	20**	20
1200 (649)	-	-	-	-	20**	20**	20

Class 300							
Temperature °F (°C)	WCB*	LCC	WC6	WC9	C5	C12	C12A
-20 to 100 (-29 to 38)	740	750	750	750	750	750	750
200 (93)	680	750	750	750	750	750	750
300 (148)	655	730	720	730	730	730	730
400 (204)	635	705	695	705	705	705	705
500 (260)	605	665	665	665	665	665	665
600 (316)	570	605	605	605	605	605	605
650 (343)	550	590	590	590	590	590	590
700 (371)	530	-	570	570	570	570	570
750 (399)	505	-	530	530	530	530	530
800 (427)	410	-	510	500	510	510	510
850 (454)	320	-	485	485	485	485	485
900 (482)	230	-	450	450	375	450	450
950 (510)	135	-	320	385	275	375	385
1000 (538)	85	-	215	265	200	255	365
1050 (566)	-	-	145	175	145	170	360
1100 (593)	-	-	95	110	100	115	300
1150 (621)	-	-	65	70	60	75	225
1200 (649)	-	-	40	40	35	50	145

Class 600							
Temperature °F (°C)	WCB*	LCC	WC6	WC9	C5	C12	C12A
-20 to 100 (-29 to 38)	1480	1500	1500	1500	1500	1500	1500
200 (93)	1360	1500	1500	1500	1500	1500	1500
300 (148)	1310	1455	1445	1455	1455	1455	1455
400 (204)	1265	1405	1385	1410	1410	1410	1410
500 (260)	1205	1330	1330	1330	1330	1330	1330
600 (316)	1135	1210	1210	1210	1210	1210	1210
650 (343)	1100	1175	1175	1175	1175	1175	1175
700 (371)	1060	-	1135	1135	1135	1135	1135
750 (399)	1015	-	1065	1065	1065	1065	1065
800 (427)	825	-	1015	1015	1015	1015	1015
850 (454)	640	-	975	975	975	975	975
900 (482)	460	-	900	900	745	900	900
950 (510)	275	-	640	755	550	755	775
1000 (538)	170	-	430	535	400	505	725
1050 (566)	-	-	290	350	290	345	720
1100 (593)	-	-	190	220	200	225	605
1150 (621)	-	-	130	135	125	150	445
1200 (649)	-	-	80	80	70	105	290

Class 900							
Temperature °F (°C)	WCB*	LCC	WC6	WC9	C5	C12	C12A
-20 to 100 (-29 to 38)	2220	2250	2250	2250	2250	2250	2250
200 (93)	2035	2250	2250	2250	2250	2250	2250
300 (148)	1965	2185	2165	2185	2185	2185	2185
400 (204)	1900	2110	2080	2115	2115	2115	2115
500 (260)	1810	1995	1995	1995	1995	1995	1995
600 (316)	1705	1815	1815	1815	1815	1815	1815
650 (343)	1650	1765	1765	1765	1765	1765	1765
700 (371)	1590	-	1705	1705	1705	1705	1705
750 (399)	1520	-	1595	1595	1595	1595	1595
800 (427)	1235	-	1525	1525	1525	1525	1525
850 (454)	955	-	1460	1460	1460	1460	1460
900 (482)	690	-	1350	1350	1120	1350	1350
950 (510)	410	-	955	1160	825	1130	1160
1000 (538)	255	-	650	805	595	760	1090
1050 (566)	-	-	430	525	430	515	1080
1100 (593)	-	-	290	330	300	340	905
1150 (621)	-	-	195	205	185	225	670
1200 (649)	-	-	125	125	105	155	430

Class 1500							
Temperature °F (°C)	WCB*	LCC	WC6	WC9	C5	C12	C12A
-20 to 100 (-29 to 38)	3705	3750	3750	3750	3750	3750	3750
200 (93)	3395	3750	3750	3750	3750	3750	3750
300 (148)	3270	3640	3610	3640	3640	3640	3640
400 (204)	3170	3520	3465	3530	3530	3530	3530
500 (260)	3015	3325	3325	3325	3325	3325	3325
600 (316)	2840	3025	3025	3025	3025	3025	3025
650 (343)	2745	2940	2940	2940	2940	2940	2940
700 (371)	2665	-	2840	2840	2840	2840	2840
750 (399)	2535	-	2660	2660	2660	2660	2660
800 (427)	2055	-	2540	2540	2540	2540	2540
850 (454)	1595	-	2435	2435	2435	2435	2435
900 (482)	1150	-	2245	2245	1870	2245	2245
950 (510)	685	-	1595	1930	1370	1885	1930
1000 (538)	430	-	1080	1335	995	1270	1820
1050 (566)	-	-	720	875	720	855	1800
1100 (593)	-	-	480	550	495	565	1510
1150 (621)	-	-	325	345	310	375	1115
1200 (649)	-	-	205	205	170	255	720

Class 2500							
Temperature °F (°C)	WCB*	LCC	WC6	WC9	C5	C12	C12A
-20 to 100 (-29 to 38)	6170	6250	6250	6250	6250	6250	6250
200 (93)	5655	6250	6250	6250	6250	6250	6250
300 (148)	5450	6070	6015	6070	6070	6070	6070
400 (204)	5280	5865	5775	5880	5880	5880	5880
500 (260)	5025	5540	5540	5540	5540	5540	5540
600 (316)	4730	5040	5040	5040	5040	5040	5040
650 (343)	4575	4905	4905	4905	4905	4905	4905
700 (371)	4425	-	4730	4730	4730	4730	4730
750 (399)	4230	-	4430	4430	4430	4430	4430
800 (427)	3430	-	4230	4230	4230	4230	4230
850 (454)	2655	-	4060	4060	4060	4060	4060
900 (482)	1915	-	3745	3745	3115	3745	3745
950 (510)	1145	-	2655	3220	2285	3145	3220
1000 (538)	715	-	1800	2230	1655	2115	3030
1050 (566)	-	-	1200	1455	1200	1430	3000
1100 (593)	-	-	800	915	830	945	2515
1150 (621)	-	-	545	570	515	630	1855
1200 (649)	-	-	345	345	285	430	1200

\* Not recommended for prolonged use above 800° F.

\*\* For weld end valves only. Flanged end ratings terminate at 1000° F.

**Note:** Packing, gasket, or bolting may limit temperature. Please advise service temperature if above 1000° F. Ratings from ASME B16.34 standard class valves. Special class weld end valves to ASME B16.34 are available on special order.

## Flange Dimensions - ASME B16.5

### Class 150 and 300

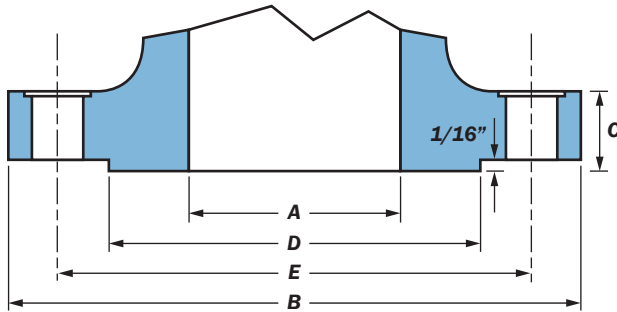

### Class 600 through 2500

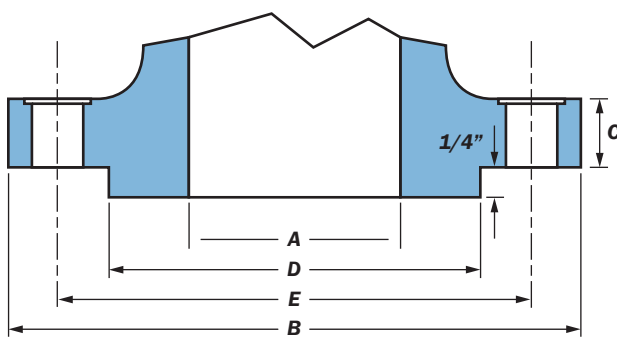

**Standards:** NPS 24 and smaller in all classes conform to ASME B16.5. NPS 30 and larger conform to ASME B16.47 (Series A).

**Facing:** End flanges are regularly furnished with a raised face having a serrated finish per MSS SP-6. The thickness of the flange dimension (C) includes the raised face for Class 150 and 300. For Class 600 through 2500, the flange dimension (C) does not include the 1/4" raised face.

**Bolt Holes:** Bolt holes are 1/8" larger than the bolt diameter. Bolt holes are drilled to straddle the center line.

Flange Dimensions in Inches								
Class 150								
Size In. (mm)	A	B	C	D	E	Stud Bolts		Hole Diam.
						No.	Diam.	
2 (50)	2.00	6.00	0.75	3.62	4.75	4	0.63	0.75
2.5 (65)	2.50	7.00	0.88	4.12	5.50	4	0.63	0.75
3 (80)	3.00	7.50	0.94	5.00	6.00	4	0.63	0.75
4 (100)	4.00	9.00	0.94	6.19	7.50	8	0.63	0.75
5 (125)	5.00	10.00	0.94	7.31	8.50	8	0.75	0.88
6 (150)	6.00	11.00	1.00	8.50	9.50	8	0.75	0.88
8 (200)	8.00	13.50	1.12	10.62	11.75	8	0.75	0.88
10 (250)	10.00	16.00	1.19	12.75	14.25	12	0.88	1.00
12 (300)	12.00	19.00	1.25	15.00	17.00	12	0.88	1.00
14 (350)	13.25	21.00	1.38	16.25	18.75	12	1.00	1.13
16 (400)	15.25	23.50	1.44	18.50	21.25	16	1.00	1.13
18 (450)	17.25	25.00	1.56	21.00	22.75	16	1.125	1.25
20 (500)	19.25	27.50	1.69	23.00	25.00	20	1.125	1.25
24 (600)	23.25	32.00	1.88	27.25	29.50	20	1.25	1.38
30 (750)	29.25	38.75	2.94	33.75	36.00	28	1.25	1.38
36 (900)	35.06	46.00	3.56	40.25	42.75	32	1.50	1.63
42 (1050)	40.87	53.00	3.81	47.00	49.50	36	1.50	1.63
48 (1200)	46.00	59.50	4.25	53.50	56.00	44	1.50	1.63

Flange Dimensions in Inches								
Class 300								
Size In. (mm)	A	B	C	D	E	Stud Bolts		Hole Diam.
						No.	Diam.	
2 (50)	2.00	6.50	0.88	3.62	5.00	8	0.63	0.75
2.5 (65)	2.50	7.50	1.00	4.12	5.88	8	0.75	0.88
3 (80)	3.00	8.25	1.12	5.00	6.62	8	0.75	0.88
4 (100)	4.00	10.00	1.25	6.19	7.88	8	0.75	0.88
5 (125)	5.00	11.00	1.38	7.31	9.25	8	0.75	0.88
6 (150)	6.00	12.50	1.44	8.50	10.62	12	0.75	0.88
8 (200)	8.00	15.00	1.62	10.62	13.00	12	0.88	1.00
10 (250)	10.00	17.50	1.88	12.75	15.25	16	1.00	1.13
12 (300)	12.00	20.50	2.00	15.00	17.75	16	1.13	1.25
14 (350)	13.25	23.00	2.12	16.25	20.25	20	1.13	1.25
16 (400)	15.25	25.50	2.25	18.50	22.50	20	1.25	1.38
18 (450)	17.00	28.00	2.38	21.00	24.75	24	1.25	1.38
20 (500)	19.00	30.50	2.50	23.00	27.00	24	1.25	1.38
24 (600)	23.00	36.00	2.75	27.25	32.00	24	1.50	1.63
30 (750)	29.00	43.00	3.62	33.75	39.25	28	1.75	1.88
36 (900)	34.50	50.00	4.12	40.25	46.00	32	2.00	2.13

Flange Dimensions in Inches								
Class 600								
Size In. (mm)	A	B	C	D	E	Stud Bolts		Hole Diam.
						No.	Diam.	
2 (50)	2.00	6.50	0.88	3.62	5.00	8	0.63	0.75
2.5 (65)	2.50	7.50	1.00	4.12	5.88	8	0.75	0.88
3 (80)	3.00	8.25	1.12	5.00	6.62	8	0.75	0.88
4 (100)	4.00	10.00	1.25	6.19	7.88	8	0.75	0.88
5 (125)	5.00	11.00	1.38	7.31	9.25	8	0.75	0.88
6 (150)	6.00	12.50	1.44	8.50	10.62	12	0.75	0.88
8 (200)	8.00	15.00	1.62	10.62	13.00	12	0.88	1.00
10 (250)	10.00	17.50	1.88	12.75	15.25	16	1.00	1.13
12 (300)	12.00	20.50	2.00	15.00	17.75	16	1.13	1.25
14 (350)	13.25	23.00	2.12	16.25	20.25	20	1.13	1.25
16 (400)	15.25	25.50	2.25	18.50	22.50	20	1.25	1.38
18 (450)	17.00	28.00	2.38	21.00	24.75	24	1.25	1.38
20 (500)	19.00	30.50	2.50	23.00	27.00	24	1.25	1.38
24 (600)	23.00	36.00	2.75	27.25	32.00	24	1.50	1.63
30 (750)	29.00	43.00	3.62	33.75	39.25	28	1.75	1.88
36 (900)	34.50	50.00	4.12	40.25	46.00	32	2.00	2.13

Flange Dimensions in Inches								
Class 900								
Size In. (mm)	A	B	C	D	E	Stud Bolts		Hole Diam.
						No.	Diam.	
2 (50)	1.88	8.50	1.50	3.62	6.50	8	0.88	1.00
2.5 (65)	2.25	9.62	1.62	4.12	7.50	8	1.00	1.13
3 (80)	2.88	9.50	1.50	5.00	7.500	8	0.88	1.00
4 (100)	3.88	11.50	1.75	6.19	9.25	8	1.13	1.25
5 (125)	4.75	13.75	2.00	7.31	11.00	8	1.25	1.38
6 (150)	5.75	15.00	2.19	8.50	12.50	12	1.13	1.25
8 (200)	7.50	18.50	2.50	10.62	15.50	12	1.38	1.50
10 (250)	9.38	21.50	2.75	12.75	18.50	16	1.38	1.50
12 (300)	11.12	24.00	3.12	15.00	21.00	20	1.38	1.50
14 (350)	12.25	25.25	3.38	16.25	22.00	20	1.50	1.63
16 (400)	14.00	27.75	3.50	18.50	24.25	20	1.63	1.75
18 (450)	15.75	31.00	4.00	21.00	27.00	20	1.88	2.00
20 (500)	17.50	33.75	4.25	23.00	29.50	20	2.00	2.13
24 (600)	21.00	41.00	5.50	27.25	35.50	20	2.50	2.63

Flange Dimensions in Inches								
Class 1500								
Size In. (mm)	A	B	C	D	E	Stud Bolts		Hole Diam.
						No.	Diam.	
2 (50)	1.88	8.50	1.50	3.62	6.50	8	0.88	1.00
2.5 (65)	2.25	9.62	1.62	4.12	7.50	8	1.00	1.13
3 (80)	2.75	10.50	1.88	5.00	8.00	8	1.13	1.25
4 (100)	3.62	12.25	2.12	6.19	9.50	8	1.25	1.38
5 (125)	4.38	14.75	2.88	7.31	11.50	8	1.50	1.63
6 (150)	5.38	15.50	3.25	8.50	12.50	12	1.38	1.50
8 (200)	7.00	19.00	3.62	10.62	15.50	12	1.63	1.75
10 (250)	8.75	23.00	4.25	12.75	19.00	12	1.88	2.00
12 (300)	10.38	26.50	4.88	15.00	22.50	16	2.00	2.13
14 (350)	11.38	29.50	5.25	16.25	25.00	16	2.25	2.38
16 (400)	13.00	32.50	5.75	18.50	27.75	16	2.50	2.63
18 (450)	14.62	36.00	6.38	21.00	30.50	16	2.75	2.88
20 (500)	16.38	38.75	7.00	23.00	32.75	16	3.00	3.13
24 (600)	19.62	46.00	8.00	27.25	39.00	16	3.50	3.63

Flange Dimensions in Inches								
Class 2500								
Size In. (mm)	A	B	C	D	E	Stud Bolts		Hole Diam.
						No.	Diam.	
2 (50)	1.50	9.25	2.00	3.62	6.75	8	1.00	1.13
2.5 (65)	1.88	10.50	2.25	4.12	7.75	8	1.13	1.25
3 (80)	2.25	12.00	2.62	5.00	9.00	8	1.25	1.38
4 (100)	2.88	14.00	3.00	6.19	10.75	8	1.50	1.63
5 (125)	3.62	16.50	3.62	7.31	12.75	8	1.75	1.88
6 (150)	4.38	19.00	4.25	8.50	14.50	8	2.00	2.13
8 (200)	5.75	21.75	5.00	10.62	17.25	12	2.00	2.13
10 (250)	7.25	26.50	6.50	12.75	21.75	12	2.50	2.63
12 (300)	8.62	30.00	7.25	15.00	24.38	12	2.75	2.88

### Auxiliary Connection Locations (Bypasses, Drains, etc.)

#### Bypasses

Bypasses serve two purposes. They are used in steam services as a means to warm the line before the main valve is opened. They are also used to balance the pressure on both sides of the main valve as an aid to reduce the torque required to open the main valve.

Cameron's NEWCO cast steel valve can be furnished with all welded bypasses when specified. The standard bypass configuration is the single valve bypass attached to the side of the main valve with the stems of both valves parallel as shown below. Piping and the OS&Y globe bypass valve have a pressure-temperature rating and corrosion resistance equal to exceeding that of the main valve.



When other bypass configurations are required, a sketch or drawing must accompany the order.

### Drains

Cameron's NEWCO cast steel valves can be furnished with drains at any of the locations shown. Standard drain connections consist of a drilled, tapped, and plugged hole at the location(s) specified. Other types of drains, including welding or threaded nipples with or without shut-off valves, can also be furnished when specified.

**Please refer to ASME B16.34 for exact auxiliary connection locations, sizes and threading information.**

Each letter in the illustration(s) below identifies the possible hole locations for auxiliary connection(s). These illustrations are for reference purposes only.

Unless specified otherwise, auxiliary connection hole sizes shall be drilled and tapped as follows:

- 2" through 4" utilizes a .50" hole
- 5" through 8" utilizes a .75" hole
- 10" and larger utilizes a 1" hole

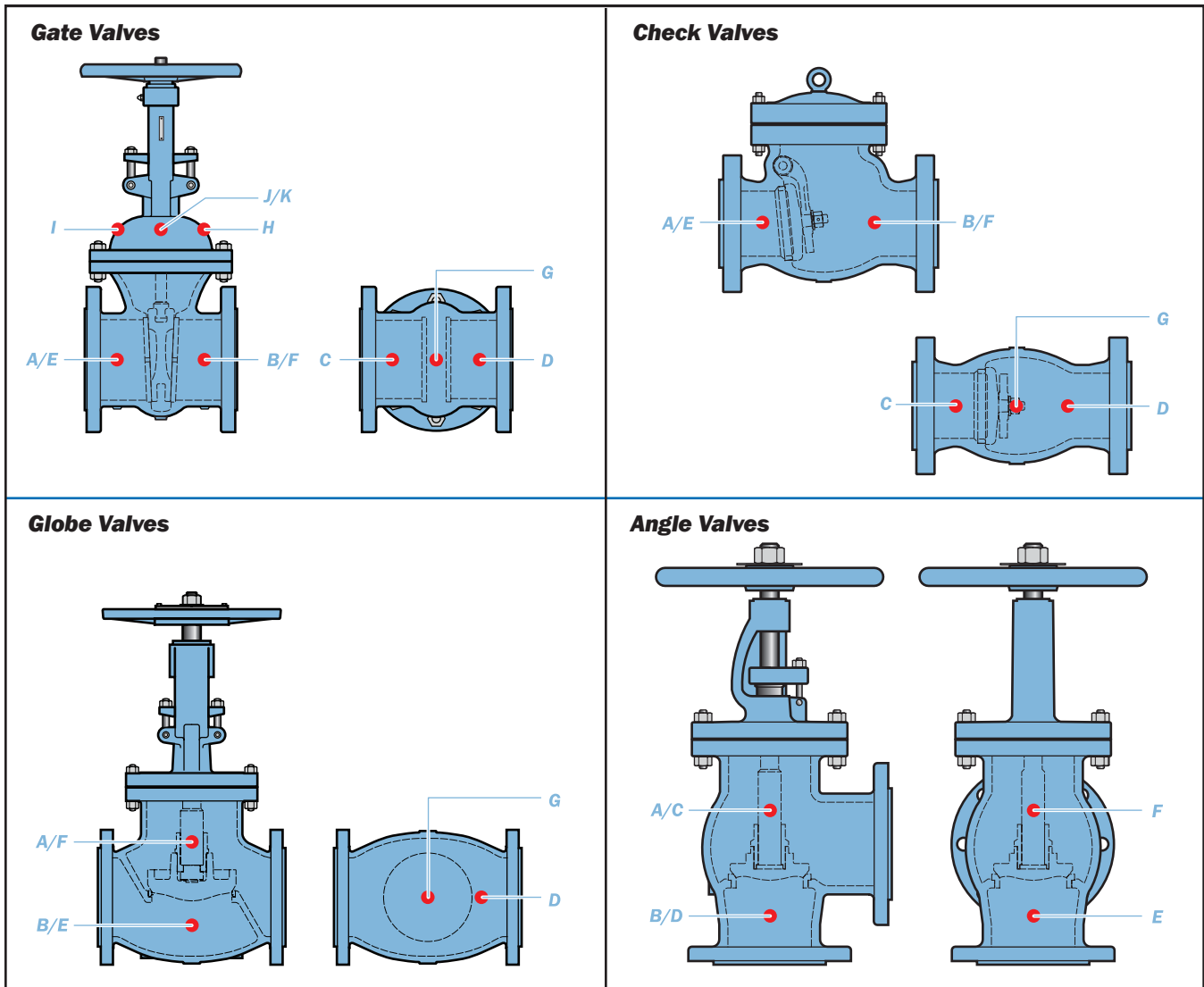

**I. CAST STEEL BOLTED BONNET GATE VALVES  
SIZES: 2" TO 48" (50MM TO 1200MM) • PRESSURE CLASS: 150 TO 1500**

Typical Cast Steel Bolted Bonnet Gate Valve Expanded View

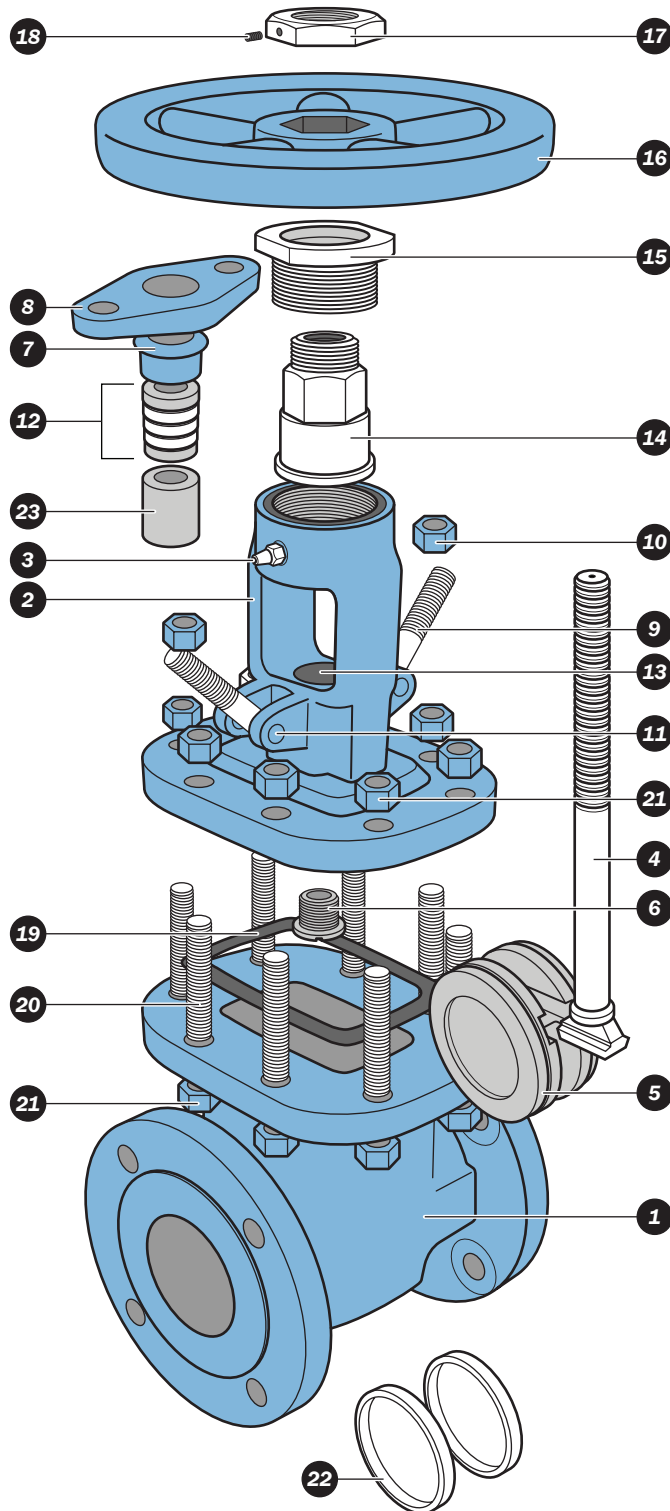

1. **Body:** Cameron's NEWCO cast steel bodies provide low resistance flow and optimum strength and performance.
2. **Yoke and Bonnet:** Cameron's NEWCO bonnet assemblies are built to the same standards as the bodies. Larger size gate valves utilize a multi-piece bonnet design.
3. **Grease Fitting:** The grease fitting allows for easy stem lubrication.
4. **Stem:** The stem is precision machined and inserts into the horizontal channel in the disc.
5. **Wedge:** Cameron's 1-piece flex wedge is machined to the tightest tolerances to ensure trouble free shut-off and cycling.
6. **Back Seat Bushing:** The back seat, when engaged with the stem head, provides a stable shut-off to the stuffing box which isolates the packing from flow exposure.
7. **Gland:** The gland compresses the packing to create a stem seal above the back seat, between the bonnet and stem.
8. **Gland Flange:** The gland flange applies pressure to the gland for accurate packing adjustments.
9. & 10. **Gland Bolts and Nuts:** The gland bolts and nuts allow for easy adjustments for packing compression.
11. **Gland Bolt Pin:** The gland bolt pin secures the gland bolts to the yoke and bonnet.
12. **Packing:** The packing creates a seal above the back seat, between the bonnet and stem.
13. **Stuffing Box:** The stuffing box contains the packing.
14. **Stem Nut:** The stem nut provides a precision guide for proper stem alignment.
15. **Yoke Bushing:** The retaining nut secures the stem nut to the bonnet assembly.
16. **Handwheel:** The handwheel cycles the valve.
17. **Handwheel Nut:** The handwheel nut secures the handwheel to the bonnet assembly.
18. **Set Screw:** The set screw prevents handwheel nut loosening.
19. **Bonnet Gasket:** The bonnet gasket creates a leakproof seal between the bonnet and body.
20. & 21. **Bonnet Studs and Nuts:** The bonnet studs and nuts secure the bonnet to the body.
22. **Seat Rings:** To ensure a stable shut-off, seat rings are aligned and seal-welded into the valve, then precision ground for optimal seating.
23. **Spacer Ring:** Assists the packing rings in creating a seal above the back seat, between the bonnet and stem.

Styles: CB2, CB3 and CB4/2
Class 150 - Sizes: 2" to 48"
Pressure Class Range: 150 to 1500

**Design and Manufacturing Standards**

Valve Design: ASME B16.34/API 600
Flange Dimensions: ASME B16.5, B16.47 (Series A)
Face to Face Dimensions: ASME B16.10
Tested in Accordance With: API 598
Recommended Spare Parts*

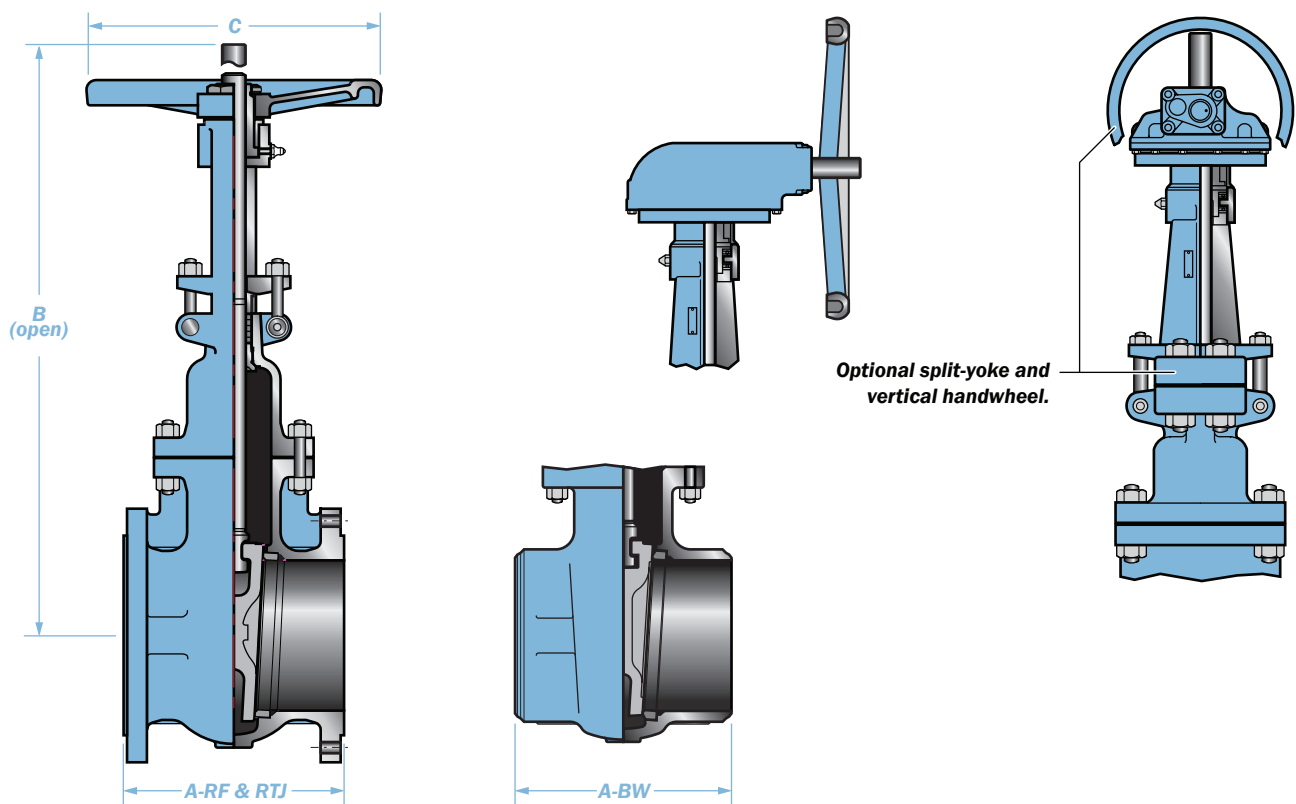

\*\* Gear operated is standard. Handwheel available upon request.

Typical Bill of Materials (See page 89 for available materials)			
Component	CB2	CB3	CB4/2
Body	ASTM A216-WCB		
Seat Rings	ASTM A105/HF		
Wedge 2" - 3"	ASTM A276-410	ASTM A216-WCB/HF	ASTM A351- CF8M/A276-316
Wedge 4" and larger	ASTM A216-WCB w/13% Chrome		ASTM A216-WCB w/316 Hardface
Stem	ASTM A182-F6a		ASTM A182-316
Yoke and Bonnet	ASTM A216-WCB		
*Bonnet Gasket	Multilayered Corrugated 316 w/Graphite		
Bonnet Nuts	ASTM A194-2H		ASTM A194-2HM
Bonnet Studs	ASTM A193-B7		ASTM A193-B7M
Back Seat Bushing	ASTM A276-410		ASTM A276-316
*Packing	Graphite w/Braided Carbon Fiber End Rings		
Gland	ASTM A276-410		ASTM A276-316
Gland Flange	ASTM A216-WCB		
Gland Bolt Pins	ASTM A36		
Gland Bolts	ASTM A307-B		
Gland Nuts	ASTM A194-2H		
Nameplate	Stainless Steel 304		
Nameplate Rivets	Stainless Steel - Commercial		
Grease Fitting	Carbon Steel - Commercial		
Stem Nut	ASTM A439-D2		
Yoke Bushing	ASTM A536 (65-45-12)		
Handwheel	ASTM A536 (65-45-12)		
Handwheel Nut	ASTM A536 (65-45-12)		
Set Screw	ASTM A193-B6		
Spacer Ring	N/A		

Class 150																			
Size	NPS	2	2.5	3	4	5	6	8	10	12	14	16	18	20	24	30	36	42	48
	DN	50	65	80	100	125	150	200	250	300	350	400	450	500	600	750	900	1050	1200
A-RF	In	7.0	7.5	8.0	9.0	10.0	10.5	11.5	13.0	14.0	15.0	16.0	17.0	18.0	20.0	24.0	28.0	31.0	34.0
	mm	178	191	203	229	254	267	292	330	356	381	406	432	457	508	610	711	813	864
A-BW	In	8.5	9.5	11.1	12.0	15.0	15.9	16.5	18.0	19.8	22.5	24.0	26.0	28.0	32.0	24.0	28.0	43.0	46.0
	mm	216	241	282	305	381	404	419	457	503	572	610	660	711	813	610	711	1092	1168
B	In	14.8	17.1	18.2	22.6	28.1	33.2	38.9	46.4	54.6	63.5	72.4	79.2	86.0	100.8	125.1	153.2	174.4	217.5
	mm	376	434	462	574	714	843	988	1179	1387	1613	1839	2012	2184	2560	3178	3891	4430	5525
C	In	8.0	8.0	8.0	10.0	13.8	14.0	16.0	18.0	20.0	22.0	24.0	27.0	30.0	30.0	35.0	43.0	35.4	35.4
	mm	203	203	203	254	350	356	406	457	508	559	610	686	762	762	889	1092	**900	**900
RF	Lbs	46	56	71	111	163	196	289	449	639	860	1190	1389	1786	2602	4466	4850	10134	15677
	Kg	21	25	32	50	74	89	131	204	290	391	541	631	812	1183	2030	1193	4600	8500
BW	Lbs	40	46	58	91	152	180	259	425	584	811	1146	1349	1720	2534	4037	4385	10198	15545
	Kg	18	21	26	41	69	82	118	193	265	369	521	613	782	1152	1835	1993	4625	8550

**Note:** Dimensions: Inches/Millimeters - Weights: Pounds/Kilograms. Larger sizes available on request. Dimensions are subject to change without notice.

Styles: CB2, CB3 and CB4/2
Class 300 - Sizes: 2" to 36"
Pressure Class Range: 150 to 1500

<b>Design and Manufacturing Standards</b>
---

Valve Design: ASME B16.34/API 600
Flange Dimensions: ASME B16.5, B16.47 (Series A)
Face to Face Dimensions: ASME B16.10
Tested in Accordance With: API 598
Recommended Spare Parts*

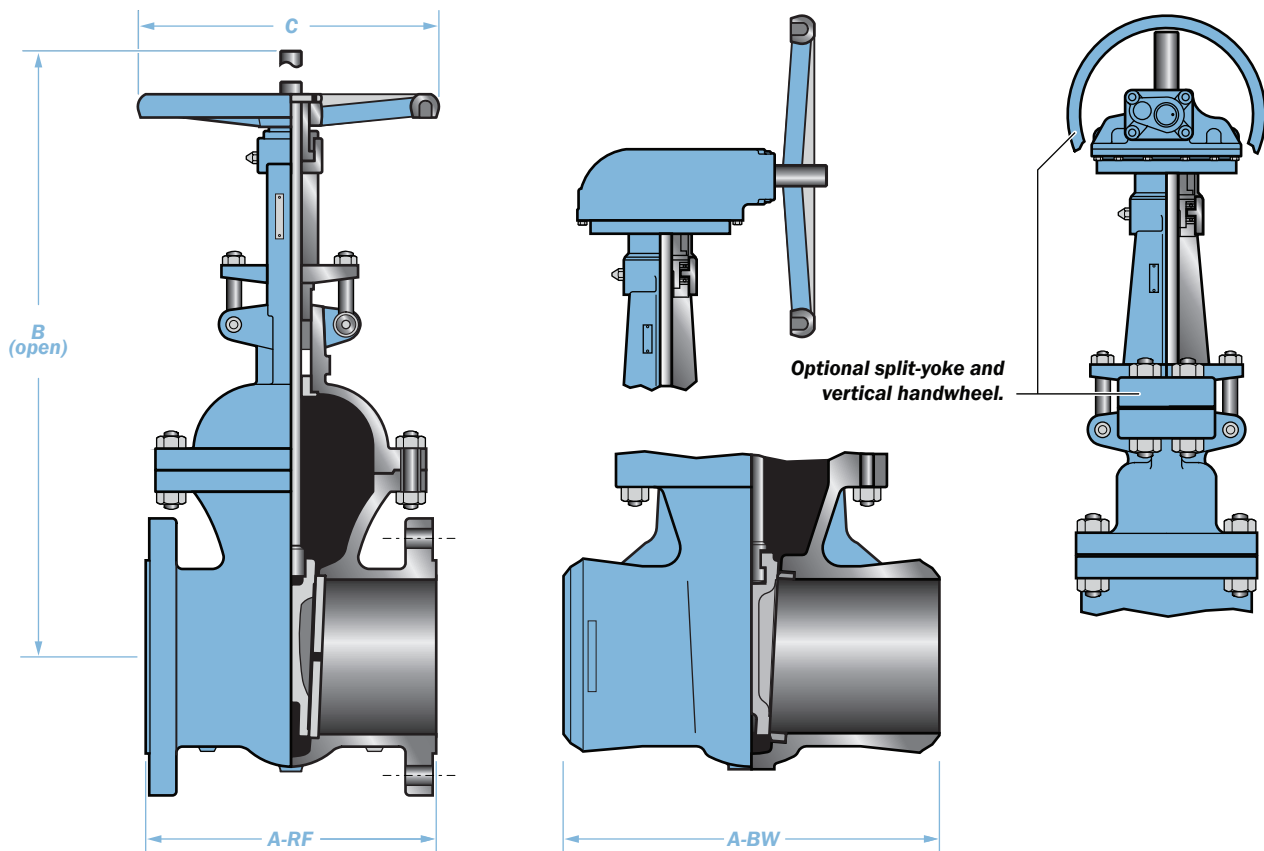

\*\* Gear operated is standard. Handwheel available upon request.

Typical Bill of Materials (See page 89 for available materials)			
Component	CB2	CB3	CB4/2
Body	ASTM A216-WCB		
Seat Rings	ASTM A105/HF		
Wedge 2" - 3"	ASTM A276-410	ASTM A216-WCB/HF	ASTM A351-CF8M/A276-316
Wedge 4" and larger	ASTM A216-WCB w/13% Chrome	ASTM A216-WCB/HF	ASTM A216-WCB w/316 Hardface
Stem	ASTM A182-F6a		ASTM A182-316
Yoke and Bonnet	ASTM A216-WCB		
*Bonnet Gasket	Spiral Wound 316 Stainless Steel/Graphite		
Bonnet Nuts	ASTM A194-2H		ASTM A194-2HM
Bonnet Studs	ASTM A193-B7		ASTM A193-B7M
Back Seat Bushing	ASTM A276-410		ASTM A276-316
*Packing	Graphite w/Braided Carbon Fiber End Rings		
Gland	ASTM A276-410		ASTM A276-316
Gland Flange	ASTM A216-WCB		
Gland Bolt Pins	ASTM A36		
Gland Bolts	ASTM A307-B		
Gland Nuts	ASTM A194-2H		
Nameplate	Stainless Steel 304		
Nameplate Rivets	Stainless Steel - Commercial		
Grease Fitting	Carbon Steel - Commercial		
Stem Nut	ASTM A439-D2		
Yoke Bushing	ASTM A536 (65-45-12)		
Handwheel	ASTM A536 (65-45-12)		
Handwheel Nut	ASTM A536 (65-45-12)		
Set Screw	ASTM A193-B6		
Spacer Ring	ASTM A276-410		

Class 300																	
Size	NPS	2	2.5	3	4	5	6	8	10	12	14	16	18	20	24	30	36
	DN	50	65	80	100	125	150	200	250	300	350	400	450	500	600	750	900
A-RF	In	8.5	9.5	11.1	12.0	15.0	15.9	16.5	18.0	19.75	30.0	33.0	36.0	39.0	45.0	55.0	68.0
	mm	216	241	282	305	381	404	419	457	502	762	838	914	991	1143	1397	1727
A-BW	In	8.5	9.5	11.1	12.0	15.0	15.9	16.5	18.0	19.75	30.0	33.0	36.0	39.0	45.0	55.0	68.0
	mm	216	241	282	305	381	404	419	457	502	762	838	914	991	1143	1397	1727
B	In	17.2	19.1	20.0	24.0	29.6	33.0	41.1	49.3	57.0	67.0	73.1	82.2	95.5	104.7	136.3	169.8
	mm	437	485	508	610	752	838	1044	1252	1448	1702	1857	2088	2426	2659	3462	4312
C	In	8.0	10.0	10.0	12.0	13.7	16.0	18.0	20.0	22.0	25.2	27.0	27.0	30.0	30.0	31.9	31.9
	mm	203	254	254	305	350	406	457	508	559	640	686	686	762	762	**810	**810
RF Wt.	Lbs	64	88	112	175	258	340	542	816	1072	1764	2183	2867	3682	5645	9702	15104
	Kg	29	40	51	80	117	155	246	371	487	802	992	1303	1674	2566	4410	6850
BW Wt.	Lbs	51	68	86	154	207	269	430	620	871	1323	1830	2381	3109	4873	8350	11003
	Kg	23	31	39	70	94	122	195	282	396	601	832	1082	1413	2215	3795	4990

**Note:** Dimensions: Inches/Millimeters - Weights: Pounds/Kilograms. Larger sizes available on request. Dimensions are subject to change without notice.

Styles: CB2, CB3 and CB4/2
Class: 600 - Sizes: 2" to 24"
Pressure Class Range: 150 to 1500

**Design and Manufacturing Standards**

Valve Design: ASME B16.34/API 600
Flange Dimensions: ASME B16.5, B16.47 (Series A)
Face to Face Dimensions: ASME B16.10
Tested in Accordance With: API 598
Recommended Spare Parts*

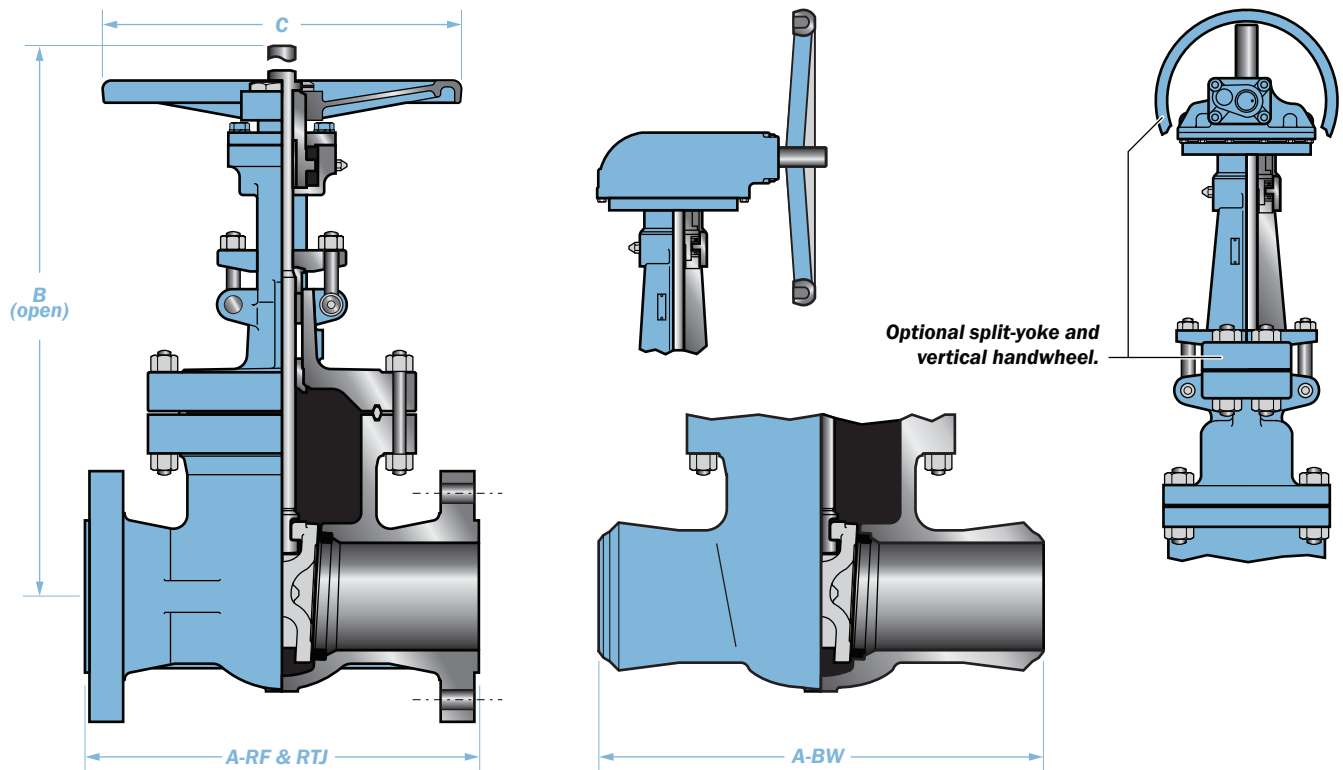

\*\* Gear operated is standard. Handwheel available upon request.



**Typical Bill of Materials (See page 89 for available materials)**

Component	CB2	CB3	CB4/2
Body	ASTM A216-WCB		
Seat Rings	ASTM A105/HF		
Wedge 2" - 3"	ASTM A276-410	ASTM A216-WCB/HF	ASTM A351-CF8M/A276-316
Wedge 4" and larger	ASTM A216-WCB w/13% Chrome	ASTM A216-WCB/HF	ASTM A216-WCB w/316 Hardface
Stem	ASTM A182-F6a		ASTM A182-316
Yoke and Bonnet	ASTM A216-WCB		
*Bonnet Gasket	Soft Steel Ring Joint		
Bonnet Nuts	ASTM A194-2H		ASTM A194-2HM
Bonnet Studs	ASTM A193-B7		ASTM A193-B7M
Back Seat Bushing	ASTM A276-410		ASTM A276-316
*Packing	Graphite w/Braided Carbon Fiber End Rings		
Gland	ASTM A276-410		ASTM A276-316
Gland Flange	ASTM A216-WCB		
Gland Bolt Pins	ASTM A36		
Gland Bolts	ASTM A307-B		
Gland Nuts	ASTM A194-2H		
Nameplate	Stainless Steel 304		
Nameplate Rivets	Stainless Steel - Commercial		
Grease Fitting	Carbon Steel - Commercial		
Stem Nut	ASTM A439-D2		
Yoke Bushing	ASTM A536 (65-45-12)		
Handwheel	ASTM A536 (65-45-12)		
Handwheel Nut	ASTM A536 (65-45-12)		
Set Screw	ASTM A193-B6		
Spacer Ring	ASTM A276-410		

**Class 600**

Size	NPS	2	2.5	3	4	5	6	8	10	12	14	16	18	20	24
	DN	50	65	80	100	125	150	200	250	300	350	400	450	500	600
A-RF	In	11.5	13.0	14.0	17.0	20.0	22.0	26.0	31.0	33.0	35.0	39.0	43.0	47.0	55.0
	mm	292	330	356	432	508	559	660	787	838	889	991	1092	1194	1397
A-BW	In	11.5	13.0	14.0	17.0	20.0	22.0	26.0	31.0	33.0	35.0	39.0	43.0	47.0	55.0
	mm	292	330	356	432	508	559	660	787	838	889	991	1092	1194	1397
A-RTJ	In	11.62	13.12	14.12	17.12		22.12	26.12	31.12	33.12	35.12	39.12	43.12	47.25	55.38
	mm	295	333	359	435		562	664	791	841	892	994	1095	1200	1406
B	In	18.3	19.9	21.7	26.9	31.6	36.5	44.0	52.8	61.4	64.8	71.7	79.3	104.8	116.9
	mm	465	505	551	683	803	927	1118	1341	1560	1646	1821	2014	2662	2970
C	In	10.0	10.0	12.0	15.0	18.0	20.0	24.0	27.0	27.0	30.0	35.0	43.0	43.0	31.9
	mm	254	254	305	381	457	508	610	686	686	762	889	1092	1092	**810
RF-RTJ	Lbs	97	132	176	320	520	680	1150	1715	2440	3150	4415	5010	6853	10337
	Kg	44	60	80	145	236	309	523	780	1109	1432	2007	2277	3108	4688
BW	Lbs	79	120	152	270	430	580	1020	1430	1950	2695	3800	5010	5640	8595
	Kg	36	55	69	123	195	264	464	650	886	1225	1727	2277	2558	3898

**Note:** Dimensions: Inches/Millimeters - Weights: Pounds/Kilograms. Larger sizes available on request. Dimensions are subject to change without notice.

Styles: CB2, CB3 and CB4/2
Class: 900 - Sizes: 2" to 12"
Pressure Class Range: 150 to 1500

**Design and Manufacturing Standards**

Valve Design: ASME B16.34/API 600
Flange Dimensions: ASME B16.5, B16.47 (Series A)
Face to Face Dimensions: ASME B16.10
Tested in Accordance With: API 598
Recommended Spare Parts*

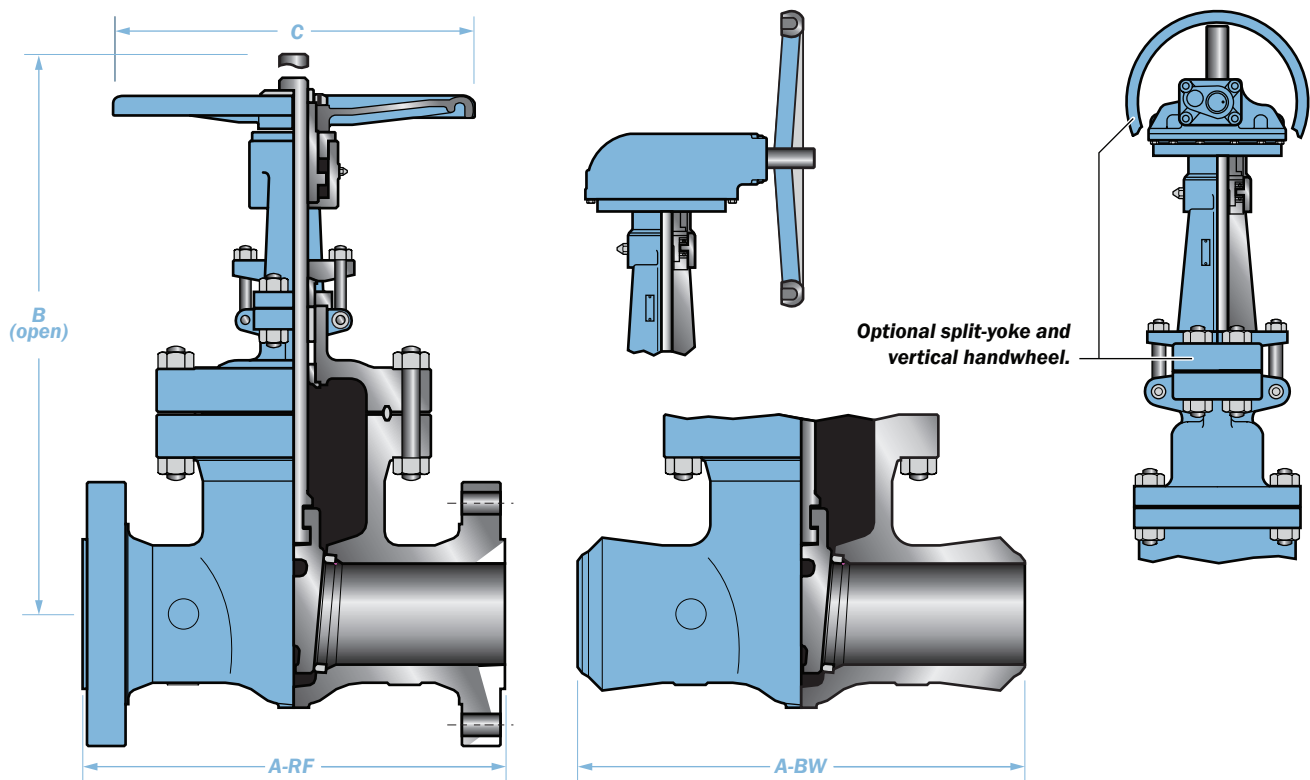

Typical Bill of Materials (See page 89 for available materials)			
Component	CB2	CB3	CB4/2
Body	ASTM A216-WCB		
Seat Rings	ASTM A105/HF		
Wedge 2" - 3"	ASTM A276-410	ASTM A216-WCB/HF	ASTM A351-CF8M/A276-316
Wedge 4" and larger	ASTM A216-WCB w/13% Chrome	ASTM A216-WCB/HF	ASTM A216-WCB w/316 Hardface
Stem	ASTM A182-F6a		ASTM A182-316
Yoke and Bonnet	ASTM A216-WCB		
*Bonnet Gasket	Soft Steel Ring Joint		
Bonnet Nuts	ASTM A194-2H		ASTM A194-2HM
Bonnet Studs	ASTM A193-B7		ASTM A193-B7M
Back Seat Bushing	ASTM A276-410		ASTM A276-316
*Packing	Graphite w/Braided Carbon Fiber End Rings		
Gland	ASTM A276-410		ASTM A276-316
Gland Flange	ASTM A216-WCB		
Gland Bolt Pins	ASTM A36		
Gland Bolts	ASTM A307-B		
Gland Nuts	ASTM A194-2H		
Nameplate	Stainless Steel 304		
Nameplate Rivets	Stainless Steel - Commercial		
Grease Fitting	Carbon Steel - Commercial		
Stem Nut	ASTM A439-D2		
Yoke Bushing	ASTM A536 (65-45-12)		
Handwheel	ASTM A536 (65-45-12)		
Handwheel Nut	ASTM A536 (65-45-12)		
Set Screw	ASTM A193-B6		
Spacer Ring	ASTM A276-410		

Class 900									
Size	NPS	2	2.5	3	4	6	8	10	12
	DN	50	65	75	100	150	200	250	300
A-RF	In	14.5	16.5	15.0	18.0	24.0	29.0	33.0	38.0
	mm	368	419	381	457	610	737	838	965
A-BW	In	14.5	16.5	15.0	18.0	24.0	29.0	33.0	38.0
	mm	368	419	381	457	610	737	838	965
A-RTJ	In	14.62	16.62	15.12	18.12	24.12	29.12	33.12	38.12
	mm	371	422	384	460	612	740	841	968
B	In	21.7	26.0	23.7	27.6	38.4	45.5	52.6	59.8
	mm	551	660	602	701	975	1156	1336	1519
C	In	9.8	9.8	13.8	13.8	22.0	25.2	30.0	30.0
	mm	250	250	350	350	560	640	760	760
RF-RTJ Wt.	Lbs	135	175	255	453	913	1705	2387	3600
	Kg	61	385	116	206	415	775	1085	1636
BW Wt.	Lbs	125	155	213	396	807	1465	1724	2790
	Kg	57	70	97	180	367	665	784	1268

**Note:** Dimensions: Inches/Millimeters - Weights: Pounds/Kilograms. Larger sizes available on request. Dimensions are subject to change without notice.

Styles: CB2, CB3 and CB4/2
Class: 1500 - Sizes: 2" to 12"
Pressure Class Range: 150 to 1500

**Design and Manufacturing Standards**

Valve Design: ASME B16.34/API 600
Flange Dimensions: ASME B16.5, B16.47 (Series A)
Face to Face Dimensions: ASME B16.10
Tested in Accordance With: API 598
Recommended Spare Parts*

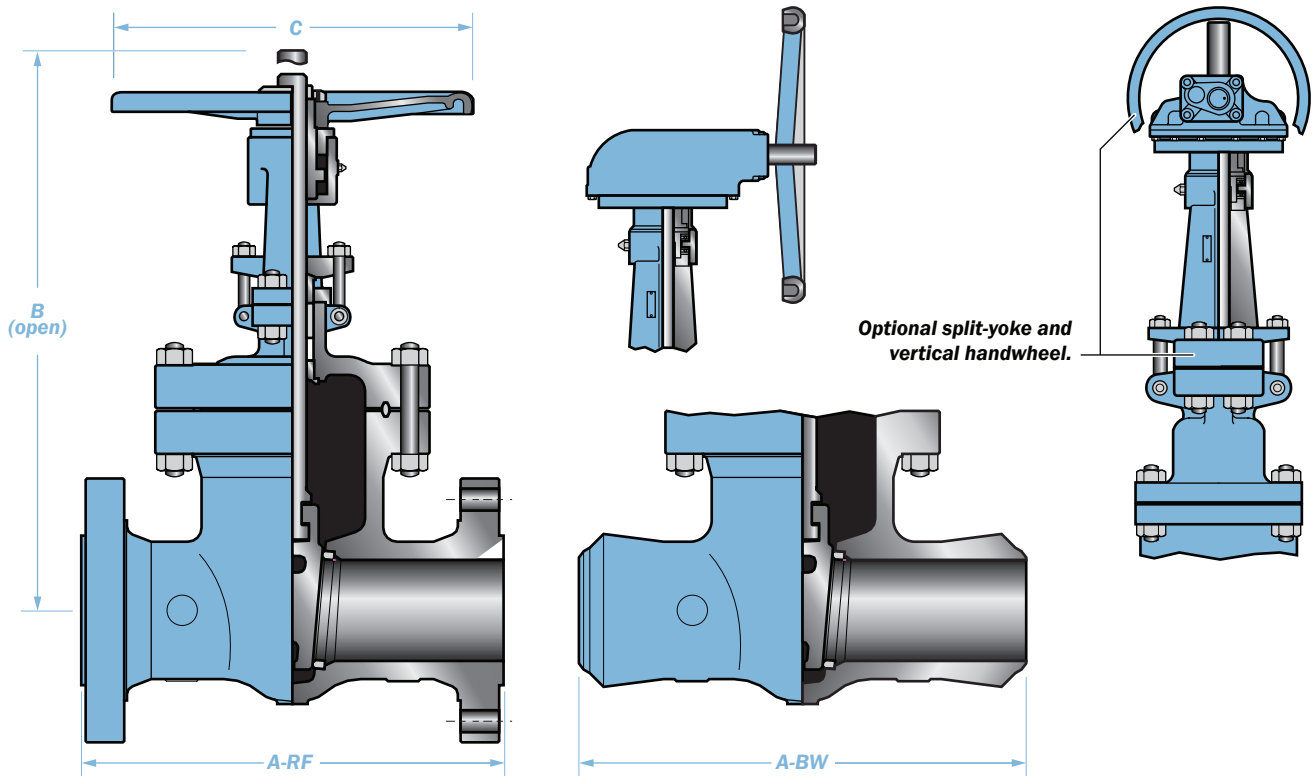

Typical Bill of Materials (See page 89 for available materials)			
Component	CB2	CB3	CB4/2
Body	ASTM A216-WCB		
Seat Rings	ASTM A105/HF		
Wedge 2" - 3"	ASTM A276-410	ASTM A216-WCB/HF	ASTM A351-CF8M/A276-316
Wedge 4" and larger	ASTM A216-WCB w/13% Chrome	ASTM A216-WCB/ HF	ASTM A216-WCB w/316 Hardface
Stem	ASTM A182-F6a		ASTM A182-316
Yoke and Bonnet	ASTM A216-WCB		
*Bonnet Gasket	Soft Steel Ring Joint		
Bonnet Nuts	ASTM A194-2H		ASTM A194-2HM
Bonnet Studs	ASTM A193-B7		ASTM A193-B7M
Back Seat Bushing	ASTM A276-410		ASTM A276-316
*Packing	Graphite w/Braided Carbon Fiber End Rings		
Gland	ASTM A276-410		ASTM A276-316
Gland Flange	ASTM A216-WCB		
Gland Bolt Pins	ASTM A36		
Gland Bolts	ASTM A307-B		
Gland Nuts	ASTM A194-2H		
Nameplate	Stainless Steel 304		
Nameplate Rivets	Stainless Steel - Commercial		
Grease Fitting	Carbon Steel - Commercial		
Stem Nut	ASTM A439-D2		
Yoke Bushing	ASTM A536 (65-45-12)		
Handwheel	ASTM A536 (65-45-12)		
Handwheel Nut	ASTM A536 (65-45-12)		
Set Screw	ASTM A193-B6		
Spacer Ring	ASTM A276-410		

Class 1500									
Size	NPS	2	2.5	3	4	6	8	10	12
	DN	50	65	75	100	150	200	250	300
A-RF	In	14.5	16.5	18.5	21.5	27.8	32.75	39.0	44.5
	mm	368	419	470	546	706	832	991	1130
A-BW	In	14.5	16.5	18.5	21.5	27.8	32.75	39.0	44.5
	mm	368	419	470	546	706	832	991	1130
A-RTJ	In	14.62	16.62	18.62	21.62	28.0	33.13	39.38	45.12
	mm	371	422	473	549	711	841	1000	1146
B	In	21.7	26.0	28.5	32.6	39.3	48.1	66.5	82.3
	mm	551	660	724	828	998	1223	1688	2090
C	In	11.8	11.8	15.75	19.6	23.6	30.0	30.0	35.0
	mm	300	300	400	500	600	760	760	889
RF-RTJ Wt.	Lbs	128	163	209	423	978	1625	4412	8414
	Kg	58	74	95	192	445	739	2001	3816
BW Wt.	Lbs	106	137	174	352	870	1650	3541	7080
	Kg	48	62	79	160	395	750	1606	3211

**Note:** Dimensions: Inches/Millimeters - Weights: Pounds/Kilograms. Larger sizes available on request. Dimensions are subject to change without notice.

## II. CAST STEEL BOLTED BONNET GLOBE VALVES SIZES: 2" TO 14" (50MM TO 350MM) • PRESSURE CLASS: 150 TO 1500

Typical Cast Steel Bolted Bonnet Globe Valve Expanded View

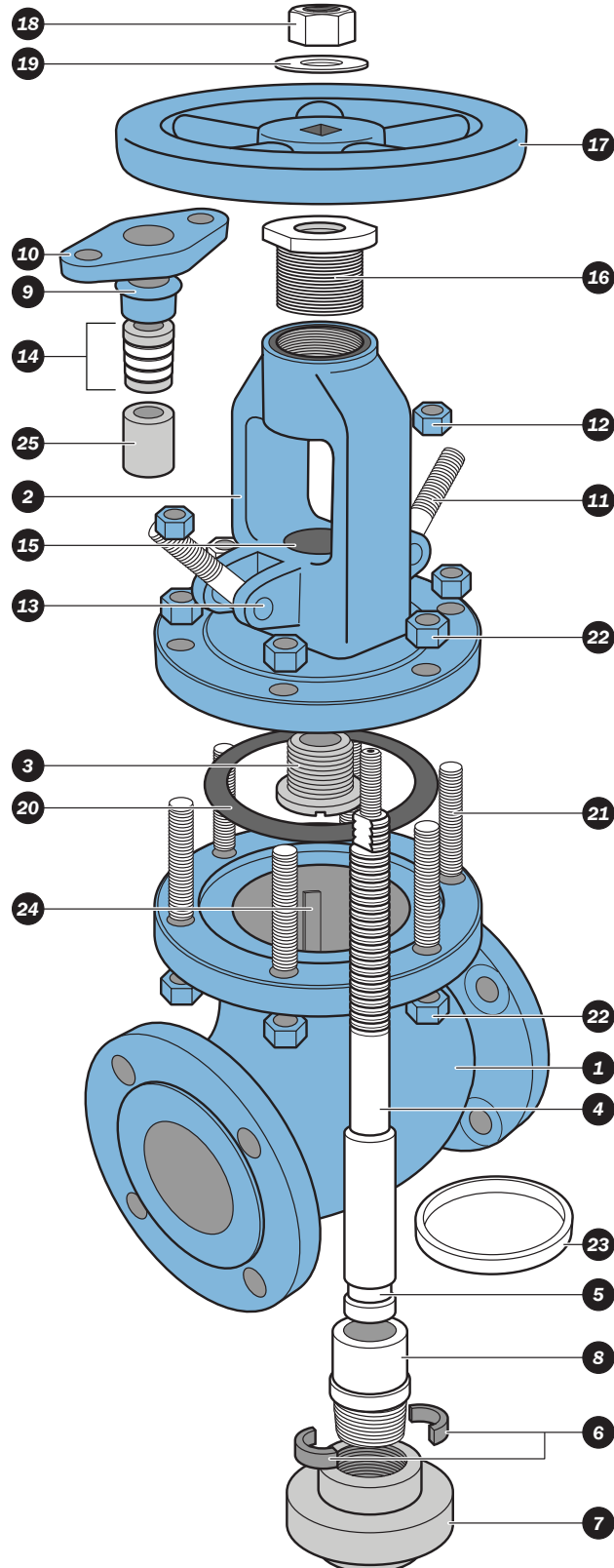

1. **Body:** Cameron's NEWCO cast steel bodies provide low resistance flow and optimum strength and performance.
2. **Bonnet:** Cameron's NEWCO bonnet assemblies are built to the same standards as the bodies.
3. **Back Seat Bushing:** The back seat, when engaged with the stem head, provides a stable shut-off to the stuffing box which isolates the packing from flow exposure.
4. **Stem:** The stem inserts vertically into the disc.
5. **Lock Groove:** The lock groove receives the split lock ring, which allows the disc nut to lift the disc during cycling.
6. **Split Ring:** The split ring allows the disc nut to lift the disc during cycling.
7. **Disc:** Cameron's plug type disc is machined to the tightest tolerances to ensure trouble free shut-off and cycling.
8. **Disc Nut:** The disc nut, in conjunction with the split lock ring, secures the disc to the stem.
9. **Gland:** The gland compresses the packing to create a stem seal above the back seat between the bonnet and stem.
10. **Gland Flange:** The gland flange applies pressure to the gland for accurate packing compression.
11. & 12. **Gland Bolts and Nuts:** The gland bolts and nuts allow for easy adjustments for packing compression.
13. **Gland Bolt Pin:** The gland bolt pin secures the gland bolts to the yoke and bonnet.
14. **Packing:** The packing creates a seal above the back seat between the bonnet and stem.
15. **Stuffing Box:** The stuffing box contains the packing.
16. **Stem Nut:** The stem nut provides a precision guide for proper stem alignment.
17. **Handwheel:** The handwheel cycles the valve.
18. **Handwheel Nut:** The handwheel nut secures the handwheel to the bonnet assembly.
19. **Handwheel Washer:** The washer helps to prevent loosening or distributes pressure evenly.
20. **Bonnet Gasket:** The bonnet gasket creates a leakproof seal between the bonnet and body.
21. & 22. **Bonnet Studs and Nuts:** The bonnet studs and nuts secure the bonnet to the body.
23. **Seat Ring:** To ensure a stable shut-off, the seat ring is aligned and seal-welded into the valve, then precision ground for optimal seating.
24. **Disc Guide:** The disc guides provide a stable track for keeping the disc aligned with the seat during cycling.
25. **Spacer Ring:** The spacer ring assists the packing rings in creating a seal above the back seat between the bonnet and stem.

Styles: CB2, CB3 and CB4/2
Class: 150 - Sizes: 2" to 14"
Pressure Class Range: 150 to 1500

**Design and Manufacturing Standards**

Valve Design: ASME B16.34/API 600
Flange Dimensions: ASME B16.5, B16.47 (Series A)
Face to Face Dimensions: ASME B16.10
Tested in Accordance With: API 598
Recommended Spare Parts*

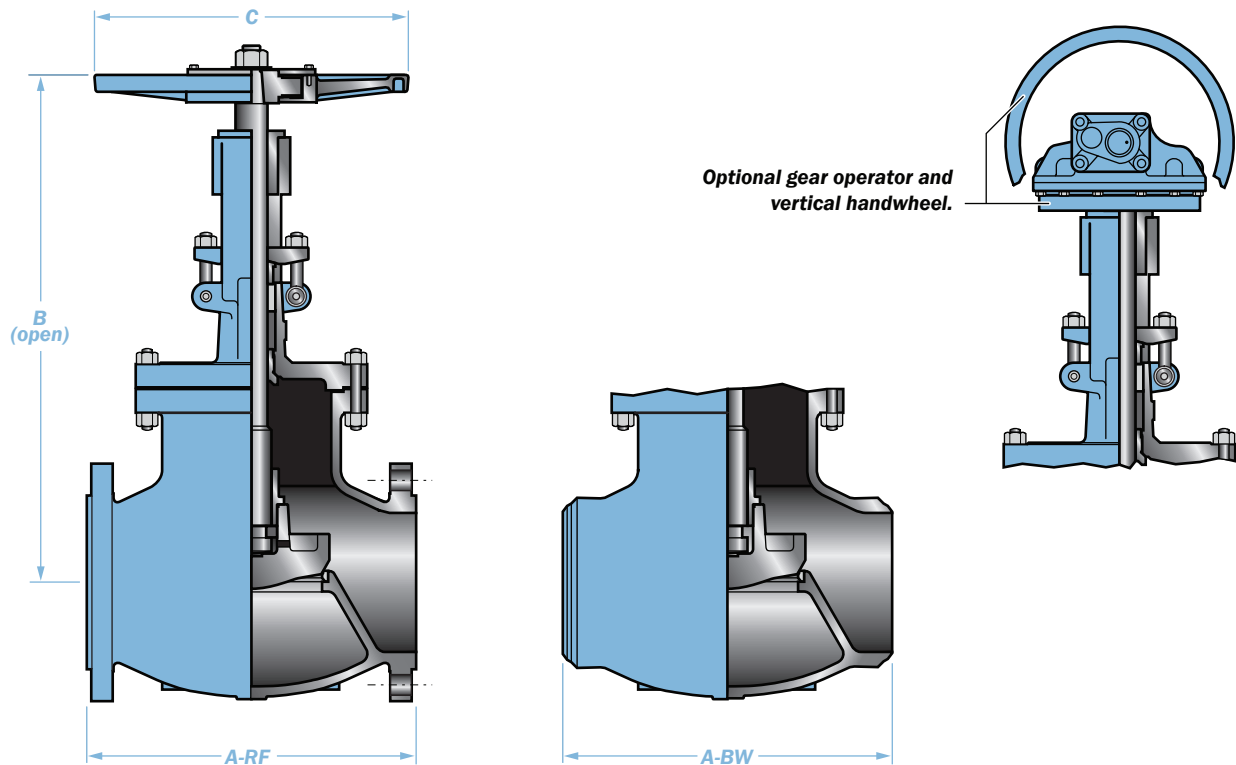



Typical Bill of Materials (See page 89 for available materials)			
Component	CB2	CB3	CB4/2
Body	ASTM A216-WCB		
Disc 2" through 4"	ASTM A276-410	ASTM A216-WCB/HF	ASTM A276-316
Disc 5" and larger	ASTM A216-WCB/13% Chrome		ASTM A216-WCB/316
Stem	ASTM A276-410		ASTM A276-316
Bonnet	ASTM A216-WCB		
*Bonnet Gasket	Spiral Wound 316 Stainless Steel/Graphite		
Bonnet Nuts	ASTM A194-2H		ASTM A194-2HM
Bonnet Studs	ASTM 193-B7		ASTM A193-B7M
Back Seat Bushing	ASTM A276-410		ASTM A276-316
*Packing	Graphite w/Braided Carbon Fiber End Rings		
Gland	ASTM A276-410		ASTM A276-316
Gland Flange	ASTM A276-WCB		
Gland Bolt Pins	ASTM A36		
Gland Nuts	ASTM A194-2H		ASTM A194-2HM
Gland Bolts	ASTM A307-B		ASTM A193-B7M
Seat Ring	ASTM A105/HF **		
Split Ring	ASTM A276-410		
Nameplate	ASTM A666-304		
Nameplate Rivets	Commercial		
Disc Nut	ASTM A276-410		ASTM A276-316
Stem Nut	ASTM A439-D2		
Handwheel Washer	ASTM A36		
Handwheel Nut	ASTM A36		
Handwheel	ASTM A536 (65-45-12)		
Spacer Ring	N/A		

Class 150											
Size	NPS	2	2.5	3	4	5	6	8	10	12	14
	DN	50	65	75	100	125	150	200	250	300	350
A-RF	In	8.0	8.5	9.5	11.5	14.0	16.0	19.5	24.5	27.5	31.0
	mm	203	216	241	292	356	406	495	622	699	787
A-BW	In	8.0	8.5	9.5	11.5	14.0	16.0	19.5	24.5	27.5	31.0
	mm	203	216	241	292	356	406	495	622	699	787
B	In	14.9	15.8	16.6	19.9	21.8	22.4	26.5	30.6	34.8	41.4
	mm	378	401	422	505	554	569	673	777	884	1052
C	In	8.0	10.0	10.0	12.0	14.0	16.0	18.0	22.0	24.0	25.2
	mm	203	254	254	305	356	406	457	559	610	640
RF Wt.	Lbs	51	73	93	137	192	243	419	507	948	1276
	Kg	23	33	42	62	87	110	190	276	476	625
BW Wt.	Lbs	51	73	93	137	192	243	419	507	948	1276
	Kg	23	33	42	62	87	110	190	276	476	625

**Note:** Dimensions: Inches/Millimeters - Weights: Pounds/Kilograms. Larger sizes available on request. Dimensions are subject to change without notice.

Styles: CB2, CB3 and CB4/2
Class: 300 - Sizes: 2" to 14"
Pressure Class Range: 150 to 1500

**Design and Manufacturing Standards**

Valve Design: ASME B16.34/API 600
Flange Dimensions: ASME B16.5, B16.47 (Series A)
Face to Face Dimensions: ASME B16.10
Tested in Accordance With: API 598 and API RP591
Recommended Spare Parts**

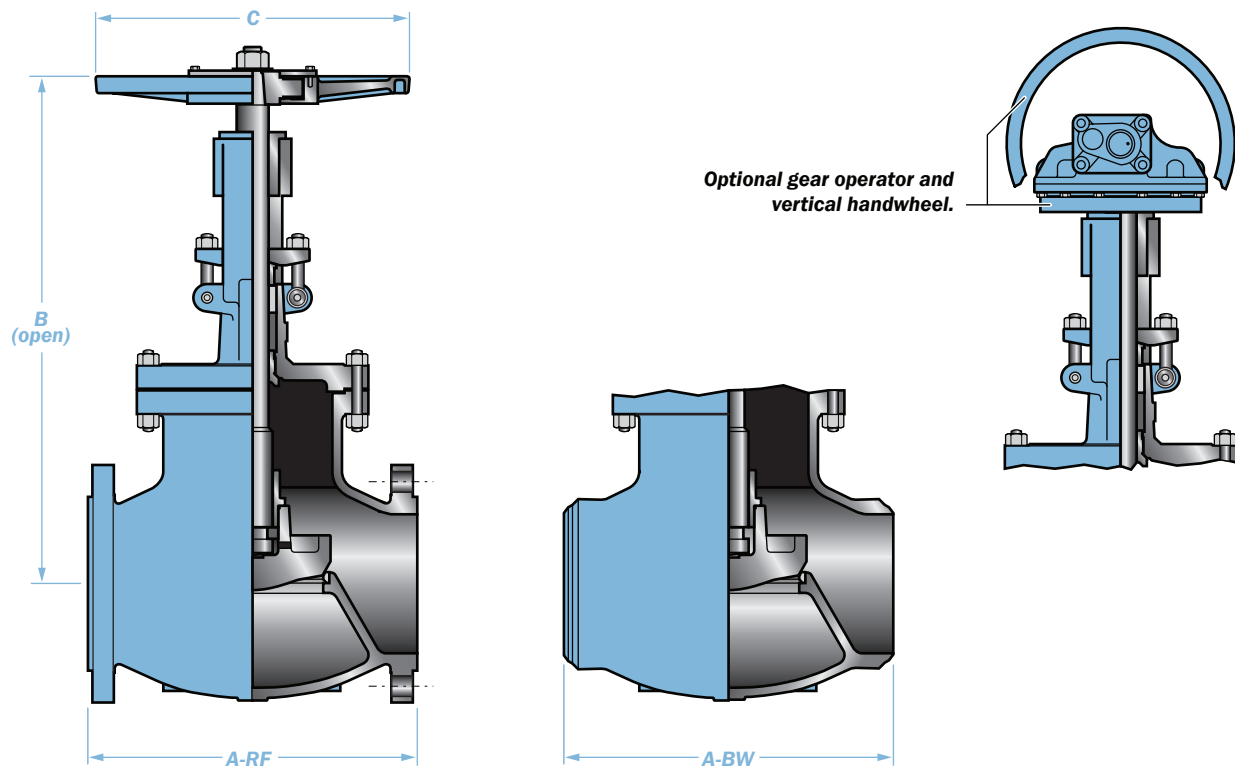

Typical Bill of Materials (See page 89 for available materials)			
Component	CB2	CB3	CB4/2
Body	ASTM A216-WCB		
Disc 2" through 4"	ASTM A276-410	ASTM A216-WCB/HF	ASTM A276-316
Disc 5" and larger	ASTM A216-WCB/ 13% Chrome		ASTM A216-WCB/316
Stem	ASTM A276-410		ASTM A276-316
Bonnet	ASTM A216-WCB		
*Bonnet Gasket	Spiral Wound 316 Stainless Steel/Graphite		
Bonnet Nuts	ASTM A194-2H		ASTM A194-2HM
Bonnet Studs	ASTM 193-B7		ASTM A193-B7M
Back Seat Bushing	ASTM A276-410		ASTM A276-316
*Packing	Graphite W/Braided Carbon Fiber End Rings		
Gland	ASTM A276-410		ASTM A276-316
Gland Flange	ASTM A276-WCB		
Gland Bolt Pins	ASTM A36		
Gland Nuts	ASTM A194-2H		ASTM A194-2HM
Gland Bolts	ASTM A307-B		ASTM A193-B7M
Seat Ring	ASTM A105/HF**		
Split Ring	ASTM A276-410		
Nameplate	ASTM A666-304		
Nameplate Rivets	Commercial		
Disc Nut	ASTM A276-410		ASTM A276-316
Stem Nut	ASTM A439-D2		
Handwheel Washer	ASTM A36		
Handwheel Nut	ASTM A36		
Handwheel	ASTM A536 (65-45-12)		
Spacer Ring	ASTM A276-410		

Class 300											
Size	NPS	2	2.5	3	4	5	6	8	10	12	14
	DN	50	65	75	100	125	150	200	250	300	350
A-RF	In	10.5	11.5	12.5	14.0	15.75	17.5	22.0	24.5	28.0	33.0
	mm	267	292	318	357	400	445	559	622	711	838
A-BW	In	10.5	11.5	12.5	14.0	15.75	17.5	22.0	24.5	28.0	33.0
	mm	267	292	318	357	400	445	559	622	711	838
B	In	16.9	17.8	19.2	23.0	27.4	30.6	36.2	40.8	47.3	54.3
	mm	429	452	488	584	696	777	919	1036	1201	1379
C	In	10.0	10.0	12.0	14.0	14.0	18.0	24.0	24.0	27.0	28.3
	mm	254	254	305	356	406	457	610	610	686	720
RF Wt.	Lbs	75.0	100.0	130.0	203.0	294.0	421.0	715	1015	1500	2446
	Kg	34	45	59	92	134	191	325	461	682	1112
BW Wt.	Lbs	55	79	101	163	242	355	566	770	1218	1996
	Kg	25	36	46	74	110	161	257	350	554	907

**Note:** Dimensions: Inches/Millimeters - Weights: Pounds/Kilograms. Larger sizes available on request. Dimensions are subject to change without notice.

Styles: CB2, CB3 and CB4/2

Class: 600 - Sizes: 2" to 8"

Pressure Class Range: 150 to 1500

**Design and Manufacturing Standards**

Valve Design: ASME B16.34/API 600

Flange Dimensions: ASME B16.5, B16.47 (Series A)

Face to Face Dimensions: ASME B16.10

Tested in Accordance With: API 598 and API RP591

Recommended Spare Parts\*\*

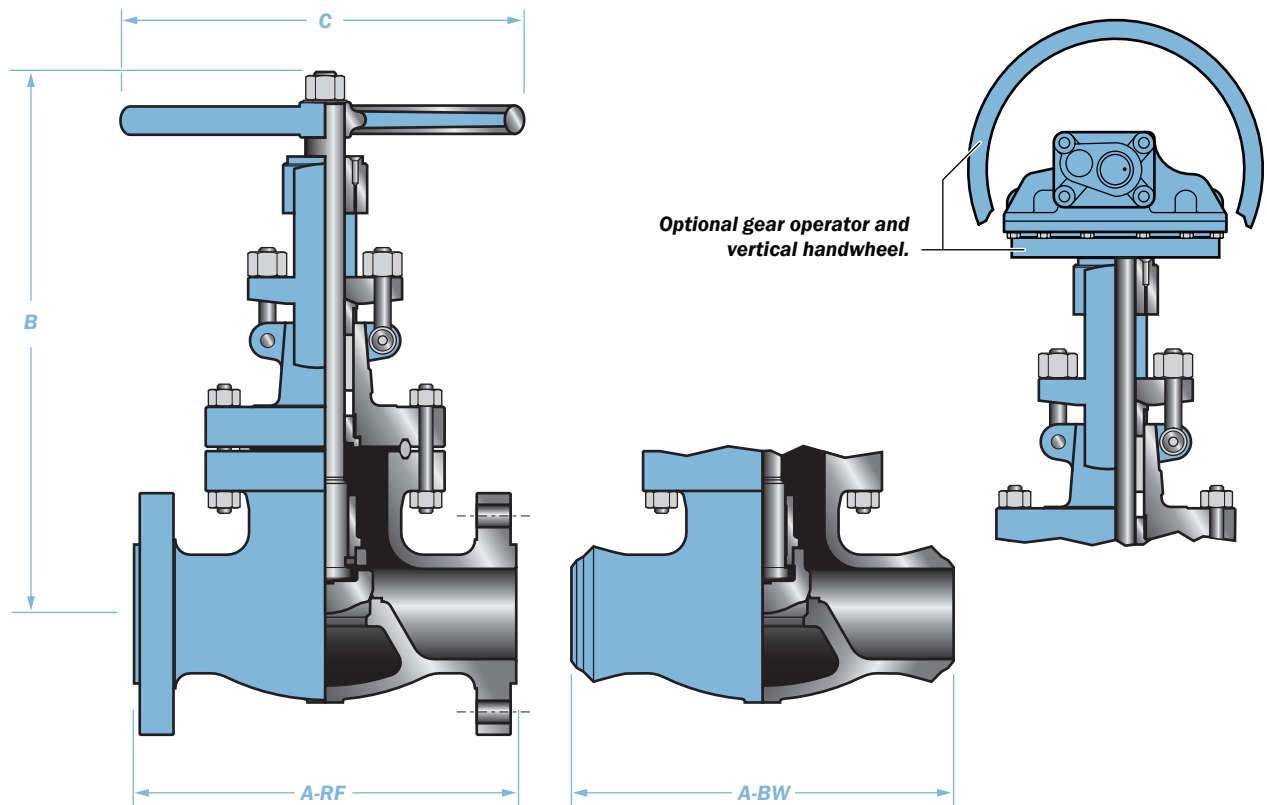

Typical Bill of Materials (See page 89 for available materials)			
Component	CB2	CB3	CB4/2
Body	ASTM A216-WCB		
Disc 2" through 4"	ASTM A276-410	ASTM A216-WCB/HF	ASTM A276-316
Disc 5" and larger	ASTM A216-WCB/ 13% Chrome		ASTM A216-WCB/316
Stem	ASTM A276-410		ASTM A276-316
Bonnet	ASTM A216-WCB		
*Bonnet Gasket	Soft Steel Ring Joint		
Bonnet Nuts	ASTM A194-2H		ASTM A194-2HM
Bonnet Studs	ASTM 193-B7		ASTM A193-B7M
Back Seat Bushing	ASTM A276-410		ASTM A276-316
*Packing	Graphite W/Braided Carbon Fiber End Rings		
Gland	ASTM A276-410		ASTM A276-316
Gland Flange	ASTM A276-WCB		
Gland Bolt Pins	ASTM A36		
Gland Nuts	ASTM A194-2H		ASTM A194-2HM
Gland Bolts	ASTM A307-B		ASTM A193-B7M
Seat Ring	Integral ASTM A216-WCB/HF		
Split Ring	ASTM A276-410		
Nameplate	ASTM A666-304		
Nameplate Rivets	Commercial		
Disc Nut	ASTM A276-410		ASTM A276-316
Stem Nut	ASTM A439-D2		
Handwheel Washer	ASTM A36		
Handwheel Nut	ASTM A36		
Handwheel	ASTM A536 (65-45-12)		
Spacer Ring	ASTM A276-410		

Class 600							
Size	NPS	2	2.5	3	4	6	8
	DN	50	65	75	100	150	200
A-RF	In	11.5	13.0	14.0	17.0	22.0	26.0
	mm	292	325	256	435	559	660
A-BW	In	11.5	13.0	14.0	17.0	22.0	26.0
	mm	292	325	256	435	559	660
B	In	18.4	20.0	24.4	29.0	37.9	44.7
	mm	467	508	620	737	963	1135
C	In	10.0	10.0	14.0	18.0	24.0	24.0
	mm	254	254	356	457	610	610
RF Wt.	Lbs	90	130	170	313	778	1245
	Kg	41	59	77	142	354	566
BW Wt.	Lbs	79	110	141	256	640	961
	Kg	36	50	64	116	291	437

**Note:** Dimensions: Inches/Millimeters - Weights: Pounds/Kilograms. Larger sizes available on request. Dimensions are subject to change without notice.

Styles: CB2, CB3 and CB4/2

Class: 900 - Sizes: 2" to 8"

Pressure Class Range: 150 to 1500

**Design and Manufacturing Standards**

Valve Design: ASME B16.34/API 600

Flange Dimensions: ASME B16.5, B16.47 (Series A)

Face to Face Dimensions: ASME B16.10

Tested in Accordance With: API 598

Recommended Spare Parts\*

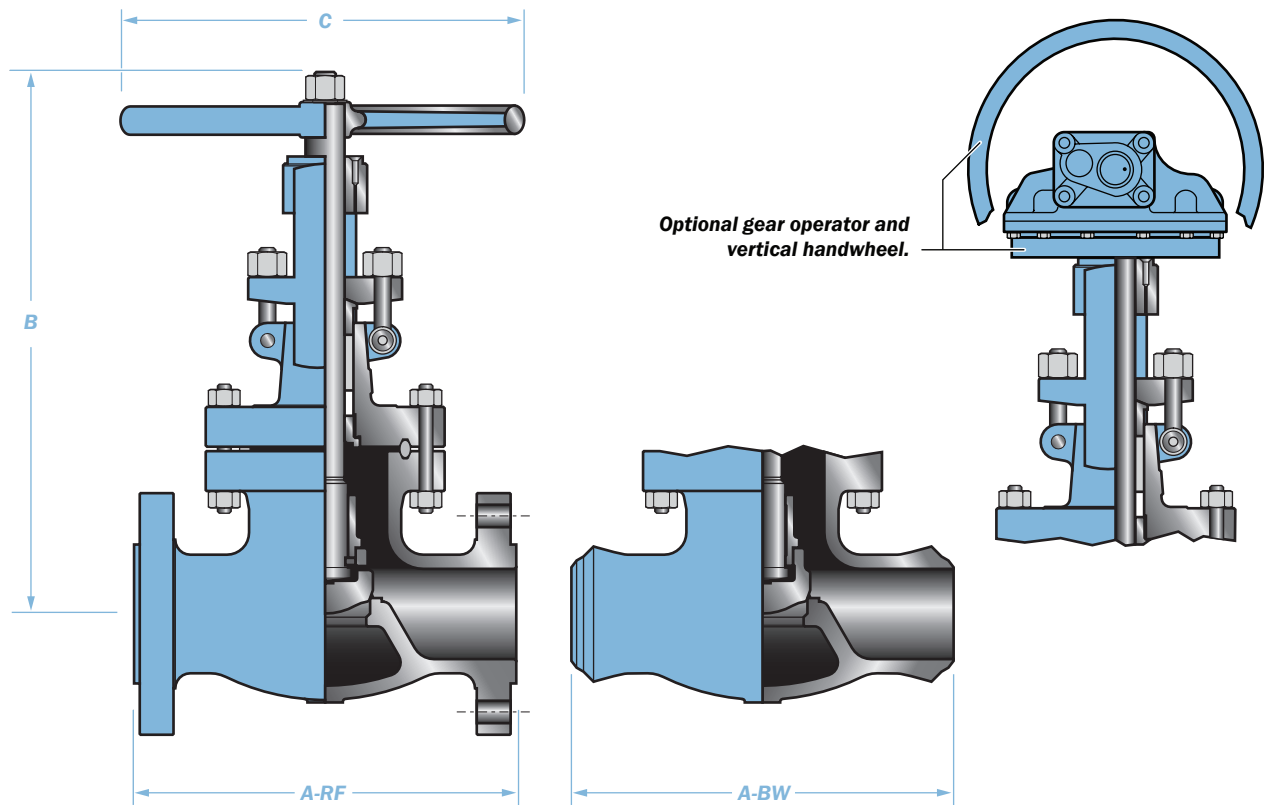

Typical Bill of Materials (See page 89 for available materials)			
Component	CB2	CB3	CB4/2
Body	ASTM A216-WCB		
Disc 2" through 4"	ASTM A276-410	ASTM A216-WCB/HF	ASTM A276-316
Disc 5" and larger	ASTM A216-WCB/ 13% Chrome		ASTM A216-WCB/316
Stem	ASTM A276-410		ASTM A276-316
Bonnet	ASTM A216-WCB		
*Bonnet Gasket	Soft Steel Ring Joint		
Bonnet Nuts	ASTM A194-2H		ASTM A194-2HM
Bonnet Studs	ASTM 193-B7		ASTM A193-B7M
Back Seat Bushing	ASTM A276-410		ASTM A276-316
*Packing	Graphite W/Braided Carbon Fiber End Rings		
Gland	ASTM A276-410		ASTM A276-316
Gland Flange	ASTM A276-WCB		
Gland Bolt Pins	ASTM A36		
Gland Nuts	ASTM A194-2H		ASTM A194-2HM
Gland Bolts	ASTM A307-B		ASTM A193-B7M
Seat Ring	Integral ASTM A216-WCB/HF		
Split Ring	ASTM A276-410		
Nameplate	ASTM A666-304		
Nameplate Rivets	Commercial		
Disc Nut	ASTM A276-410		ASTM A276-316
Stem Nut	ASTM A439-D2		
Handwheel Washer	ASTM A36		
Handwheel Nut	ASTM A36		
Handwheel	ASTM A536 (65-45-12)		
Spacer Ring	ASTM A276-410		

Class 900						
Size	NPS	2	3	4	6	8
	DN	50	75	100	150	200
A-RF	In	14.5	15.0	18.0	24.0	29.0
	mm	368	381	457	610	737
A-BW	In	14.5	15.0	18.0	24.0	29.0
	mm	368	381	457	610	737
B	In	22.6	26.0	30.6	39.6	60.1
	mm	574	660	777	1006	1527
C	In	13.8	17.7	17.7	22.0	28.3
	mm	350	450	450	560	720
RF Wt.	Lbs	198	335	440	1675	2090
	Kg	90	152	200	761	950
BW Wt.	Lbs	176	297	376	1144	1634
	Kg	80	135	171	520	743

**Note:** Dimensions: Inches/Millimeters - Weights: Pounds/Kilograms. Larger sizes available on request. Dimensions are subject to change without notice.

Styles: CB2, CB3 and CB4/2
Class: 1500 - Sizes: 2" to 6"
Pressure Class Range: 150 to 1500

**Design and Manufacturing Standards**

Valve Design: ASME B16.34/API 600
Flange Dimensions: ASME B16.5, B16.47 (Series A)
Face to Face Dimensions: ASME B16.10
Tested in Accordance With: API 598
Recommended Spare Parts*

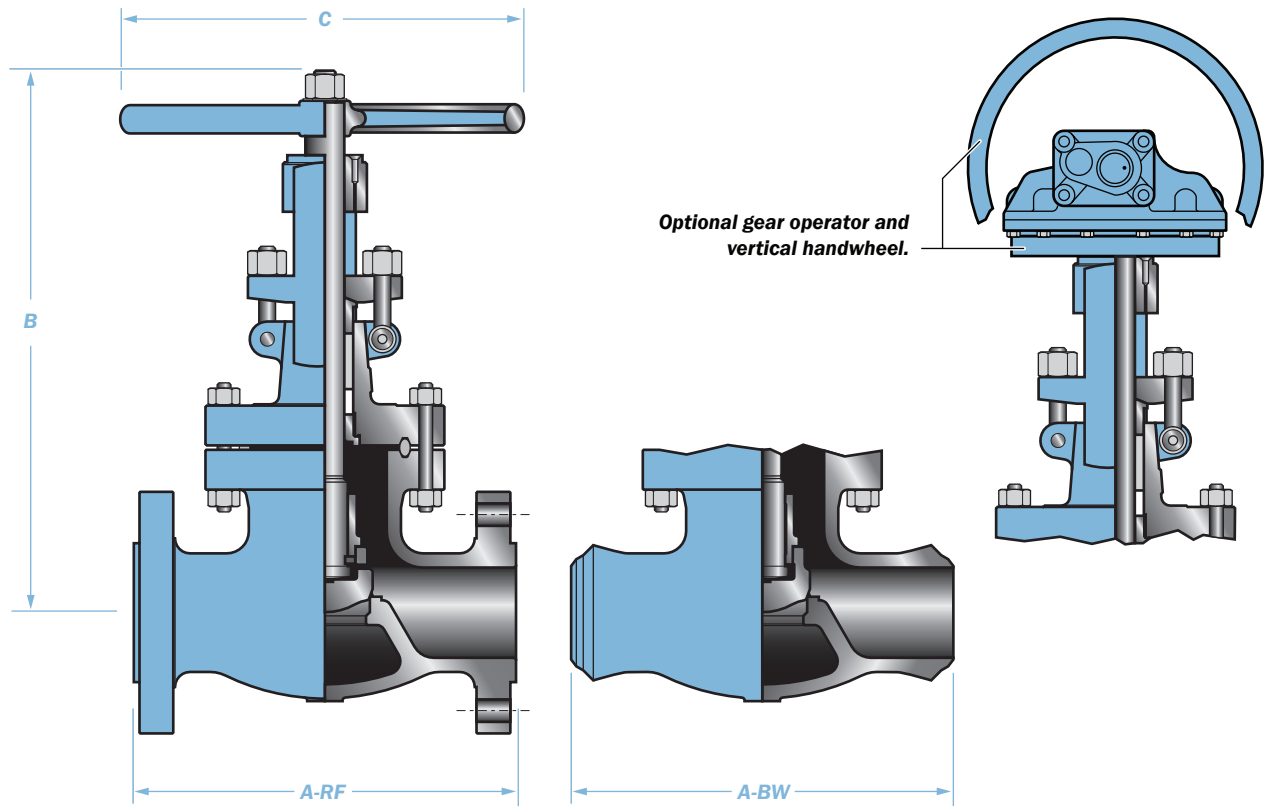



Typical Bill of Materials (See page 89 for available materials)			
Component	CB2	CB3	CB4/2
Body	ASTM A216-WCB		
Disc 2" through 4"	ASTM A276-410	ASTM A216-WCB/HF	ASTM A276-316
Disc 5" and larger	ASTM A216-WCB/ 13% Chrome		ASTM A216- WCB/316
Stem	ASTM A276-410		ASTM A276-316
Bonnet	ASTM A216-WCB		
*Bonnet Gasket	Soft Steel Ring Joint		
Bonnet Nuts	ASTM A194-2H		ASTM A194-2HM
Bonnet Studs	ASTM 193-B7		ASTM A193-B7M
Back Seat Bushing	ASTM A276-410		ASTM A276-316
*Packing	Graphite W/Braided Carbon Fiber End Rings		
Gland	ASTM A276-410		ASTM A276-316
Gland Flange	ASTM A276-WCB		
Gland Bolt Pins	ASTM A36		
Gland Nuts	ASTM A194-2H		ASTM A194-2HM
Gland Bolts	ASTM A307-B		ASTM A193-B7M
Seat Ring	Integral ASTM A216-WCB/HF		
Split Ring	ASTM A276-410		
Nameplate	ASTM A666-304		
Nameplate Rivets	Commercial		
Disc Nut	ASTM A276-410		ASTM A276-316
Stem Nut	ASTM A439-D2		
Handwheel Washer	ASTM A36		
Handwheel Nut	ASTM A36		
Handwheel	ASTM A536 (65-45-12)		
Spacer Ring	ASTM A276-410		

Class 1500					
Size	NPS	2	3	4	6
	DN	50	75	100	150
A-RF	In	14.5	18.5	21.5	27.75
	mm	368	470	546	705
A-BW	In	14.5	18.5	21.5	27.75
	mm	368	470	546	705
B	In	19.6	25.6	30.8	36.5
	mm	498	650	782	927
C	In	13.8	17.7	19.7	25.2
	mm	350	450	500	640
RF	Lbs	209	551	959	1191
Wt.	Kg	95	250	436	541
BW	Lbs	143	460	830	996
Wt.	Kg	65	209	377	453

**Note:** Dimensions: Inches/Millimeters - Weights: Pounds/Kilograms. Larger sizes available on request. Dimensions are subject to change without notice.

### III. CAST STEEL BOLTED BONNET ANGLE VALVES SIZES: 2" TO 12" (50MM TO 300MM) • PRESSURE CLASS: 150 TO 600

Typical Cast Steel Bolted Bonnet Angle Valve Expanded View

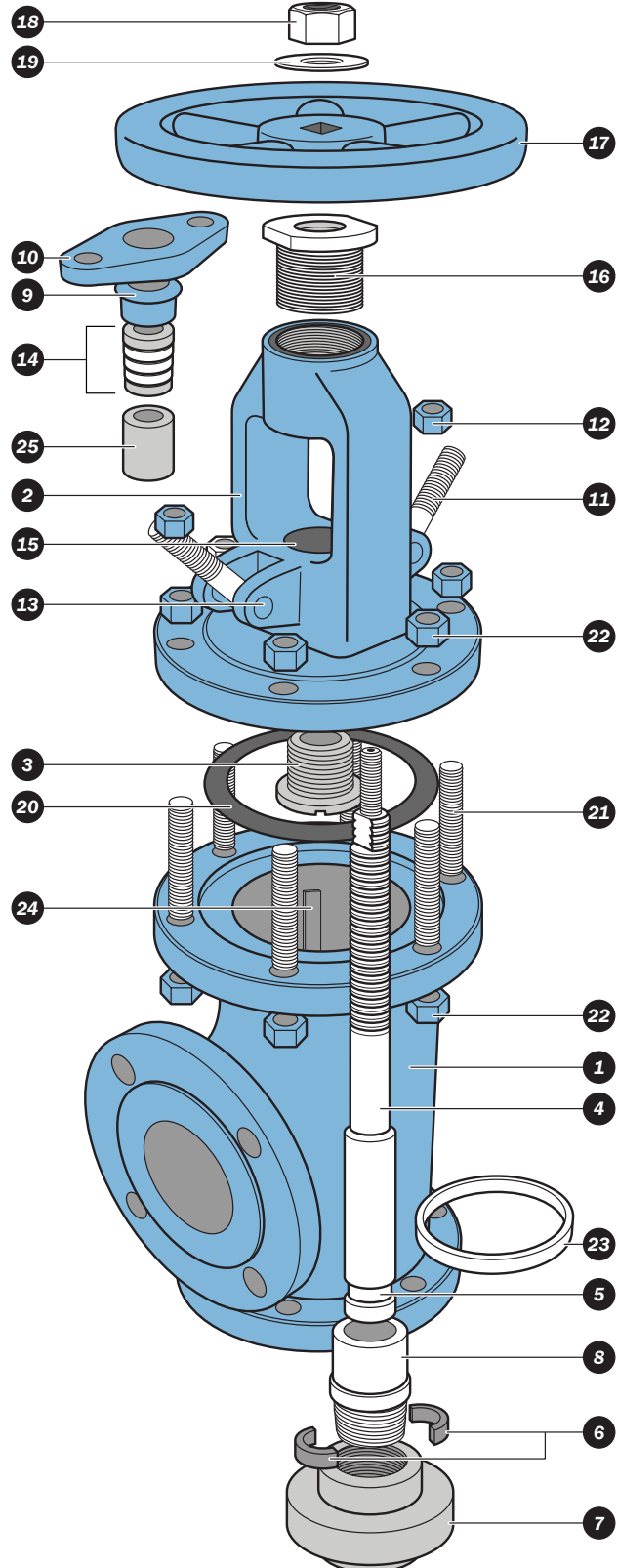

1. **Body:** Cameron's NEWCO cast steel bodies provide low resistance flow and optimum strength and performance.
2. **Bonnet:** Cameron's NEWCO bonnet assemblies are built to the same standards as the bodies.
3. **Back Seat Bushing:** The back seat, when engaged with the stem head, provides a stable shut-off to the stuffing box which isolates the packing from flow exposure.
4. **Stem:** The stem inserts vertically into the disc.
5. **Lock Groove:** The lock groove receives the split lock ring which allows the disc nut to lift the disc during cycling.
6. **Split Ring:** The split ring allows the disc nut to lift the disc during cycling.
7. **Disc:** The disc is machined to the tightest tolerances to ensure trouble free shut-off and cycling.
8. **Disc Nut:** The disc nut, in conjunction with the split lock ring, secures the disc to the stem.
9. **Gland:** The gland compresses the packing to create a stem seal above the back seat between the bonnet and stem.
10. **Gland Flange:** The gland flange applies pressure to the gland for accurate packing compression.
11. & 12. **Gland Bolts and Nuts:** The gland bolts and nuts allow for easy adjustments for packing compression.
13. **Gland Bolt Pin:** The gland bolt pin secures the gland bolts to the yoke and bonnet.
14. **Packing:** The packing creates a seal above the back seat between the bonnet and stem.
15. **Stuffing Box:** The stuffing box contains the packing.
16. **Stem Nut:** The stem nut provides a precision guide for proper stem alignment.
17. **Handwheel:** The handwheel cycles the valve.
18. **Handwheel Nut:** The handwheel nut secures the handwheel to the bonnet assembly.
19. **Handwheel Washer:** The washer helps to prevent loosening or distributes pressure evenly.
20. **Bonnet Gasket:** The bonnet gasket creates a leakproof seal between the bonnet and body.
21. & 22. **Bonnet Studs and Nuts:** The bonnet studs and nuts secure the bonnet to the body.
23. **Seat Ring:** To ensure a stable shut-off, the seat rings are aligned and seal-welded into the valve, then precision ground for optimal seating.
24. **Disc Guide:** The disc guides provide a stable track for keeping the disc aligned with the seat during cycling.
25. **Spacer Ring:** The spacer ring assists the packing rings in creating a seal above the back seat between the bonnet and stem.

Styles: CB2, CB3 and CB4/2
Class: 150 - Sizes: 2" to 12"
Pressure Class Range: 150 to 600

<b>Design and Manufacturing Standards</b>
---

Valve Design: ASME B16.34/API 600
Flange Dimensions: ASME B16.5, B16.47 (Series A)
Face to Face Dimensions: ASME B16.10
Tested in Accordance With: API 598
Recommended Spare Parts*

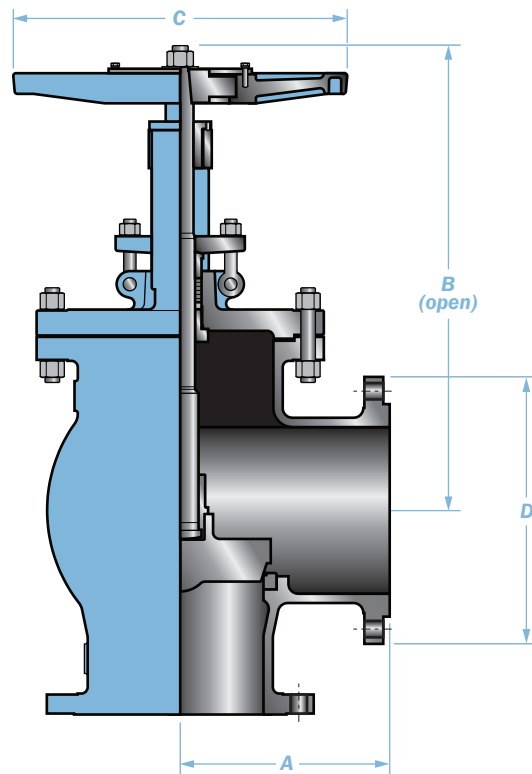

Typical Bill of Materials (See page 89 for available materials)			
Component	CB2	CB3	CB4/2
Body	ASTM A216 GR.WCB		
Seat Ring	ASTM A105/HF		
Disc 2" through 4"	ASTM A276-410	ASTM A216-WCB/HF	ASTM A276-316
Disc 5" and larger	ASTM A216-WCB/ 13% Chrome		ASTM A216-WCB/316
Disc Nut	ASTM A276-410		ASTM A276-316
Stem	ASTM A276-410		ASTM A276-316
*Bonnet Gasket	Spiral Wound 316 Stainless Steel/Graphite		
Bonnet	ASTM A216-WCB		
Bonnet Studs	ASTM 193-B7		ASTM A193-B7M
Bonnet Nuts	ASTM A194-2H		ASTM A194-2HM
Back Seat Bushing	ASTM A276-410		ASTM A276-316
Packing	Graphite w/Braided Carbon Fiber End Rings		
Gland Bolt Pins	ASTM A36		
Gland Bolts	ASTM 193-B7		ASTM A193-B7M
Gland	ASTM A276-410		ASTM A276-316
Gland Flange	ASTM A216-WCB		
Gland Nuts	ASTM A194-2H		ASTM A194-2HM
Stem Nut	ASTM A439-D2		
Split Ring	ASTM A276-410		
Handwheel Washer	ASTM A36		
Handwheel Nut	ASTM A36		
Handwheel	ASTM A539 Type (65-45-12)		
Spacer Ring	ASTM A276-410		ASTM A276-316

Class 150								
Size	NPS	2	3	4	6	8	10	12
	DN	50	75	100	150	200	250	300
A	In	4.0	4.75	5.75	8.0	9.75	12.25	13.75
	mm	107	121	146	203	248	311	349
B	In	15.2	16.9	20.4	21.8	27.4	31	37.8
	mm	386	429	518	554	696	787	960
C	In	8	10	12	15	18	22	24
	mm	203	254	305	381	457	559	610
D	In	6	7.5	9	11	13.5	16	19
	mm	152	191	229	279	343	406	483
RF Wt.	Lbs	57	84	141	234	399	611	794
	Kg	26	38	64	106	181	278	361

**Note:** Dimensions: Inches/Millimeters - Weights: Pounds/Kilograms. Larger sizes available on request. Dimensions are subject to change without notice.

Styles: CB2, CB3 and CB4/2

Class: 300 - Sizes: 2" to 12"

Pressure Class Range: 150 to 600

### Design and Manufacturing Standards

Valve Design: ASME B16.34/API 600

Flange Dimensions: ASME B16.5, B16.47 (Series A)

Face to Face Dimensions: ASME B16.10

Tested in Accordance With: API 598

Recommended Spare Parts\*

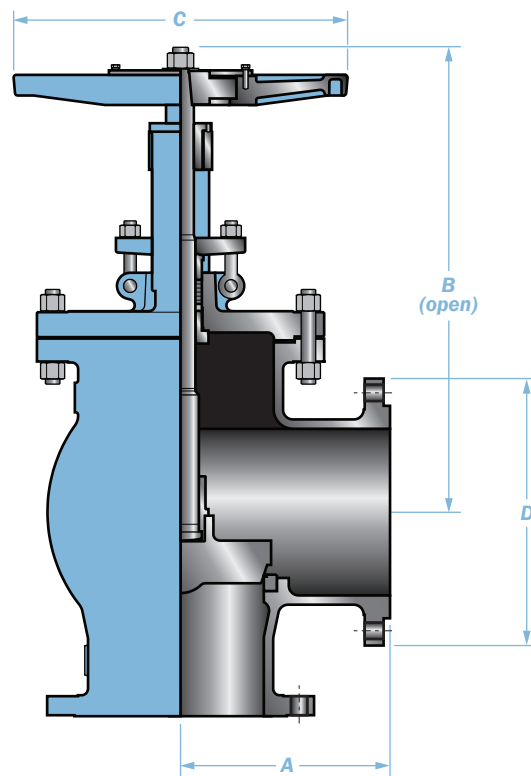

Typical Bill of Materials (See page 89 for available materials)			
Component	CB2	CB3	CB4/2
Body	ASTM A216 GR.WCB		
Seat Ring	ASTM A105/HF		
Disc 2" through 4"	ASTM A276-410	ASTM A216-WCB/HF	ASTM A276-316
Disc 5" and larger	ASTM A216-WCB/ 13% Chrome		ASTM A216-WCB/316
Disc Nut	ASTM A276-410		ASTM A276-316
Stem	ASTM A276-410		ASTM A276-316
*Bonnet Gasket	Spiral Wound 316 Stainless Steel/Graphite		
Bonnet	ASTM A216-WCB		
Bonnet Studs	ASTM 193-B7		ASTM A193-B7M
Bonnet Nuts	ASTM A194-2H		ASTM A194-2HM
Back Seat Bushing	ASTM A276-410		ASTM A276-316
Packing	Graphite w/Braided Carbon Fiber End Rings		
Gland Bolt Pins	ASTM A36		
Gland Bolts	ASTM 193-B7		ASTM A193-B7M
Gland	ASTM A276-410		ASTM A276-316
Gland Flange	ASTM A216-WCB		
Gland Nuts	ASTM A194-2H		ASTM A194-2HM
Stem Nut	ASTM A439-D2		
Split Ring	ASTM A276-410		
Handwheel Washer	ASTM A36		
Handwheel Nut	ASTM A36		
Handwheel	ASTM A539 Type (65-45-12)		
Spacer Ring	ASTM A276-410		ASTM A276-316

Class 300								
Size	NPS	2	3	4	6	8	10	12
	DN	50	75	100	150	200	250	300
A	In	5.25	6.25	7	8.75	11	12.25	14
	mm	133	159	178	222	279	311	356
B	In	15	16.9	21.7	28	30.7	37.5	41.6
	mm	381	429	551	711	780	953	1049
C	In	10	12	14	17	24	24	27
	mm	254	305	356	432	610	610	686
D	In	6.5	8.25	10	12.5	15	17.5	20.5
	mm	165	210	254	318	381	445	521
RF Wt.	Lbs	68	108	198	392	560	934	1288
	Kg	31	49	90	178	255	425	586

**Note:** Dimensions: Inches/Millimeters - Weights: Pounds/Kilograms. Larger sizes available on request. Dimensions are subject to change without notice.

Styles: CB2, CB3 and CB4/2

Class: 600 - Sizes: 2" to 8"

Pressure Class Range: 150 to 600

### Design and Manufacturing Standards

Valve Design: ASME B16.34/API 600

Flange Dimensions: ASME B16.5, B16.47 (Series A)

Face to Face Dimensions: ASME B16.10

Tested in Accordance With: API 598

Recommended Spare Parts\*

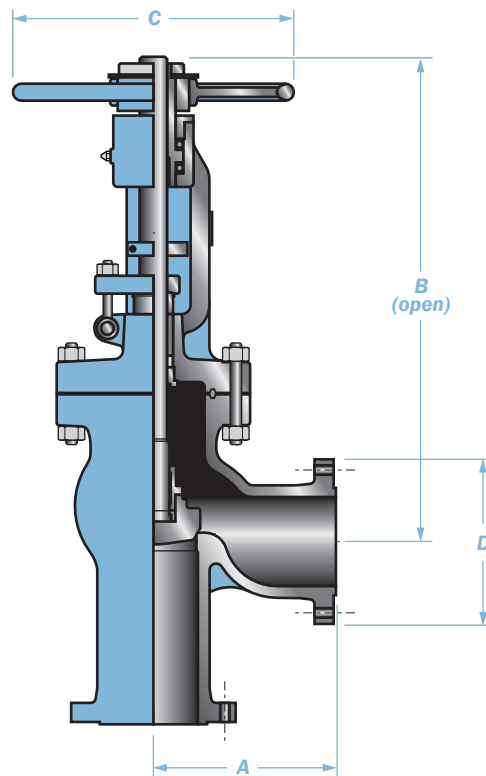



Typical Bill of Materials (See page 89 for available materials)			
Component	CB2	CB3	CB4/2
Body	ASTM A216 GR.WCB		
Seat Ring	ASTM A105/HF		
Disc 2" through 4"	ASTM A276-410	ASTM A216-WCB/HF	ASTM A276-316
Disc 5" and larger	ASTM A216-WCB/13% Chrome		ASTM A216-WCB/316
Disc Nut	ASTM A276-410		ASTM A276-316
Stem	ASTM A276-410		ASTM A276-316
*Bonnet Gasket	Spiral Wound 316 Stainless Steel/Graphite		
Bonnet	ASTM A216-WCB		
Bonnet Studs	ASTM 193-B7		ASTM A193-B7M
Bonnet Nuts	ASTM A194-2H		ASTM A194-2HM
Back Seat Bushing	ASTM A276-410		ASTM A276-316
Packing	Graphite w/Braided Carbon Fiber End Rings		
Gland Bolt Pins	ASTM A36		
Gland Bolts	ASTM 193-B7		ASTM A193-B7M
Gland	ASTM A276-410		ASTM A276-316
Gland Flange	ASTM A216-WCB		
Gland Nuts	ASTM A194-2H		ASTM A194-2HM
Stem Nut	ASTM A439-D2		
Split Ring	ASTM A276-410		
Handwheel Washer	ASTM A36		
Handwheel Nut	ASTM A36		
Handwheel	ASTM A539 Type (65-45-12)		
Spacer Ring	ASTM A276-410		ASTM A276-316

Class 600							
Size	NPS	2	2.5	3	4	6	8
	DN	50	75	100	150	200	250
A	In	5.75	6.5	7.0	8.5	11.0	13.0
	mm	146	165	178	216	279	330
B	In	18.9	20.9	19.8	22.2	28.2	38.5
	mm	480	531	503	564	716	978
C	In	8.8	9.8	11.0	14.0	17.7	24.8
	mm	224	249	279	356	450	630
D	In	6.5	7.5	8.3	9.0	14.0	16.5
	mm	165	191	211	229	356	419
RF Wt.	Lbs	79	110	141	256	640	961
	Kg	36	50	64	116	291	437

**Note:** Dimensions: Inches/Millimeters - Weights: Pounds/Kilograms. Larger sizes available on request. Dimensions are subject to change without notice.

**IV. CAST STEEL BOLTED COVER SWING CHECK VALVES  
SIZES: 2" TO 24" (50MM TO 600MM) • PRESSURE CLASS: 150 TO 1500**

Typical Cast Steel Bolted Cover Swing Check Valve Expanded View

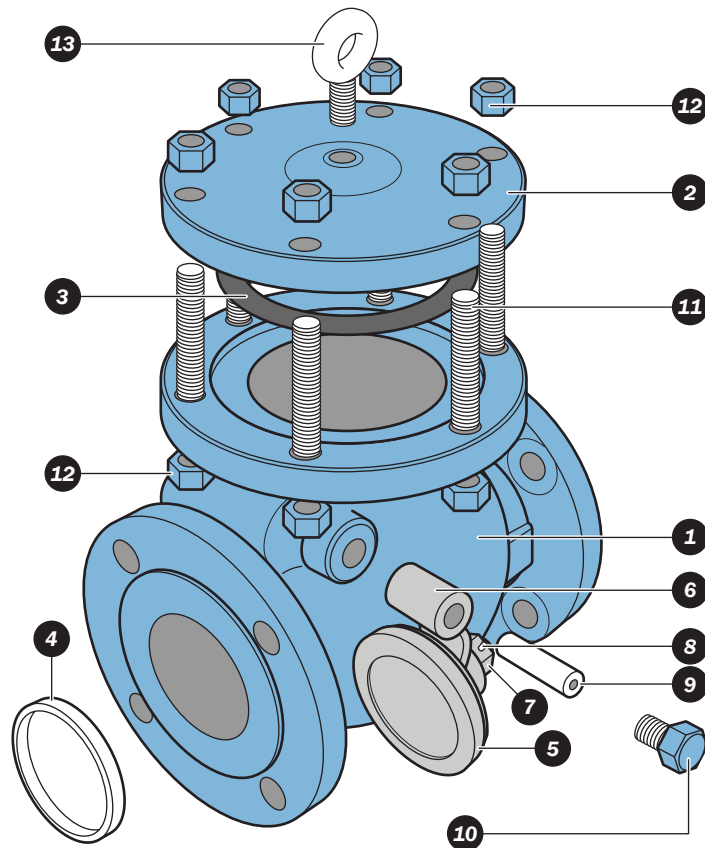

*Note: Classes 150 and 300 use external hinge pin.*

1. **Body:** Cameron's NEWCO cast steel bodies provide low resistance flow and optimum strength and performance.
2. **Cover:** The cover allows access to internal components.
3. **Cover Gasket:** The cover gasket creates a leakproof seal between the bonnet and body.
4. **Seat Ring:** To ensure a stable shut-off, the seat ring is aligned and seal-welded into the valve, then precision ground for optimal seating.
5. **Disc:** The disc allows unidirectional flow and restricts back flow with trouble free shut-off.
6. **Swing Arm:** The swing arm allows the disc to open and close.
7. & 8. **Disc Nut and Pin:** The disc nut and pin secure the disc to the swing arm.
9. **Hinge Pin:** The hinge pin provides a stable mechanism for the swing arm to operate.
10. **Plug:** The plug secures the arm pin inside the valve.
11. **Plug Gasket:** The plug gasket creates a leak-proof seal between the plug and body.
12. & 13. **Cover Studs and Nuts:** The cover studs and nuts secure the bonnet to the body.
14. **Eyebolt:** The eyebolt is use to aid in lifting the valve.

Styles: CB2, CB3 and CB4/2
Class: 150 - Sizes: 2" to 24"
Pressure Class Range: 150 to 1500
<b>Design and Manufacturing Standards</b>
Valve Design: ASME B16.34/API 600
Flange Dimensions: ASME B16.5, B16.47 (Series A)
Face to Face Dimensions: ASME B16.10
Tested in Accordance With: API 598
Recommended Spare Parts*

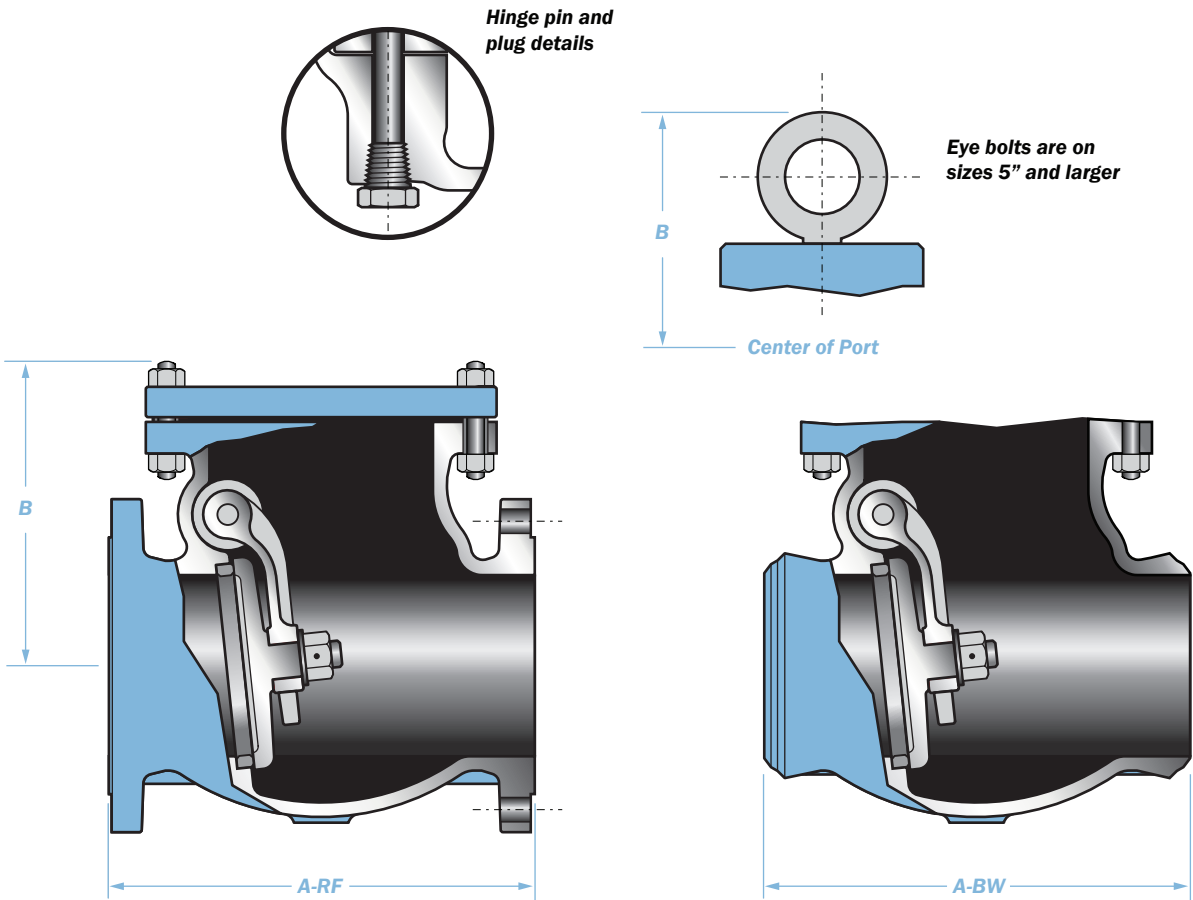

Typical Bill of Materials (See page 89 for available materials)			
Component	CB2	CB3	CB4/2
Body	ASTM A216-WCB		
Cover	ASTM A105N		
Disc 2" through 5"	ASTM A182-F6a	ASTM A182-F6a/HF	ASTM A182-F316
Disc 6" and larger	ASTM A216-WCB/13% Chrome	ASTM A216-WCB/HF	ASTM A216-WCB/316 Faced
Swing Arm	ASTM A216-WCB		
Seat Ring	ASTM A105/HF		
*Cover Gasket	Spiral Wound 316 Stainless Steel/Graphite		
Hinge Pin	ASTM A276-410		ASTM A276-316
Name Plate	304 Stainless Steel		
Plug Gasket	Stainless Steel		
Cover Bolt	ASTM A193-B7		ASTM A193-B7M
Cover Nut	AISI 1020		
Plug	ASTM A276-410		ASTM A276-316
Disc Pin	ASTM A276-316		
Disc Nut	A194-8		
Eye Bolt 5" through 24"	Carbon Steel		

Class 150															
Size	NPS	2	2.5	3	4	5	6	8	10	12	14	16	18	20	24
	DN	50	75	100	150	125	150	200	250	300	350	400	450	500	600
A-RF	In	8.0	8.5	9.5	11.5	13.0	14.0	19.5	24.5	27.5	31.0	34.0	38.5	38.5	51.0
	mm	203	216	241	292	330	356	495	622	699	787	864	978	978	1295
A-BW	In	8.0	8.5	9.5	11.5	13.0	14.0	19.5	24.5	27.5	31.0	34.0	38.5	38.5	51.0
	mm	203	216	241	292	330	356	495	622	699	787	864	978	978	1295
B	In	6.8	7.4	7.7	8.5	12.3	12.8	14.3	17.2	17.9	19.6	21.2	24.2	27.4	30.0
	mm	173	188	196	216	315	325	363	437	455	498	538	615	696	762
RF Wt.	Lbs	36	51	64	98	135	181	298	463	688	898	1147	1367	1808	2866
	Kg	16	23	29	45	61	398	135	210	313	408	521	621	822	1308
BW Wt.	Lbs	29	38	49	73	110	146	243	421	591	766	979	1190	1585	2250
	Kg	13	17	22	33	50	66	110	191	269	348	445	541	720	1123

**Note:** Dimensions: Inches/Millimeters - Weights: Pounds/Kilograms. Larger sizes available on request. Dimensions are subject to change without notice.

Styles: CB2, CB3 and CB4/2
Class: 300 - Sizes: 2" to 24"
Pressure Class Range: 150 to 1500
<b>Design and Manufacturing Standards</b>
Valve Design: ASME B16.34/API 600
Flange Dimensions: ASME B16.5, B16.47 (Series A)
Face to Face Dimensions: ASME B16.10
Tested in Accordance With: API 598
Recommended Spare Parts*

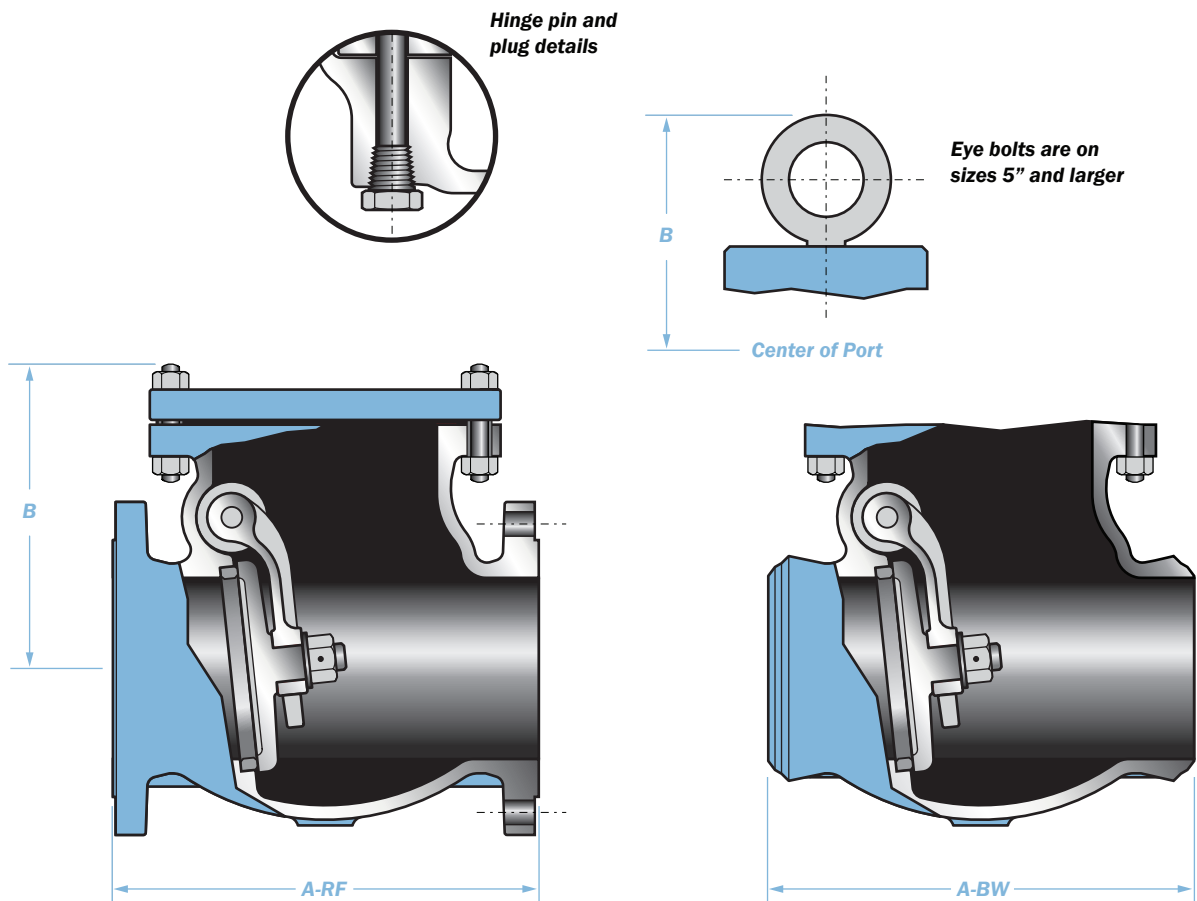

Typical Bill of Materials (See page 89 for available materials)			
Component	CB2	CB3	CB4/2
Body	ASTM A216-WCB		
Cover	ASTM A105N		
Disc 2" through 5"	ASTM A182-F6a	ASTM A182-F6a/HF	ASTM A182-F316
Disc 6" and larger	ASTM A216-WCB/13% Chrome	ASTM A216-WCB/HF	ASTM A216-WCB/316 Faced
Swing Arm	ASTM A216-WCB		
Seat Ring	ASTM A105/HF		
*Cover Gasket	Spiral Wound 316 Stainless Steel/Graphite		
Hinge Pin	ASTM A276-410		ASTM A276-316
Name Plate	304 Stainless Steel		
Plug Gasket	Stainless Steel		
Cover Bolt	ASTM A193-B7		ASTM A193-B7M
Cover Nut	ASTM A276-410		ASTM A276-316
Plug	AISI 1020		
Disc Pin	ASTM A276-316		
Disc Nut	A194-8		
Eye Bolt 5" through 24"	Carbon Steel		

Class 300															
Size	NPS	2	2.5	3	4	5	6	8	10	12	14	16	18	20	24
	DN	50	75	100	150	125	150	200	250	300	350	400	450	500	600
A-RF	In	10.5	11.5	12.5	14.0	15.75	17.5	21.0	24.5	28.0	33.0	34.0	38.5	40.0	53.0
	mm	267	292	318	356	400	445	533	622	711	838	864	978	1016	1346
A-BW	In	10.5	11.5	12.5	14.0	15.75	17.5	21.0	24.5	28.0	33.0	34.0	38.5	40.0	53.0
	mm	267	292	318	356	400	445	533	622	711	838	864	978	1016	1346
B	In	7.6	8.3	8.9	9.8	13.3	14.0	15.9	18.7	21.9	23.1	25.2	28.6	30.2	33.6
	mm	193	211	226	249	338	356	404	475	556	587	640	726	767	853
RF Wt.	Lbs	58	86	95	144	232	283	433	694	1003	1345	1720	2271	2888	4718
	Kg	26	39	43	65	105	129	197	315	456	611	782	1032	1313	2145
BW Wt.	Lbs	44	55	78	103	185	214	341	562	815	1087	1397	1873	2400	3995
	Kg	20	25	35	47	84	97	155	255	370	494	635	851	1091	1816

**Note:** Dimensions: Inches/Millimeters - Weights: Pounds/Kilograms. Larger sizes available on request. Dimensions are subject to change without notice.

Styles: CB2, CB3 and CB4/2
Class: 600 - Sizes: 2" to 14"
Pressure Class Range: 150 to 1500

**Design and Manufacturing Standards**

Valve Design: ASME B16.34/API 600
Flange Dimensions: ASME B16.5, B16.47 (Series A)
Face to Face Dimensions: ASME B16.10
Tested in Accordance With: API 598
Recommended Spare Parts*

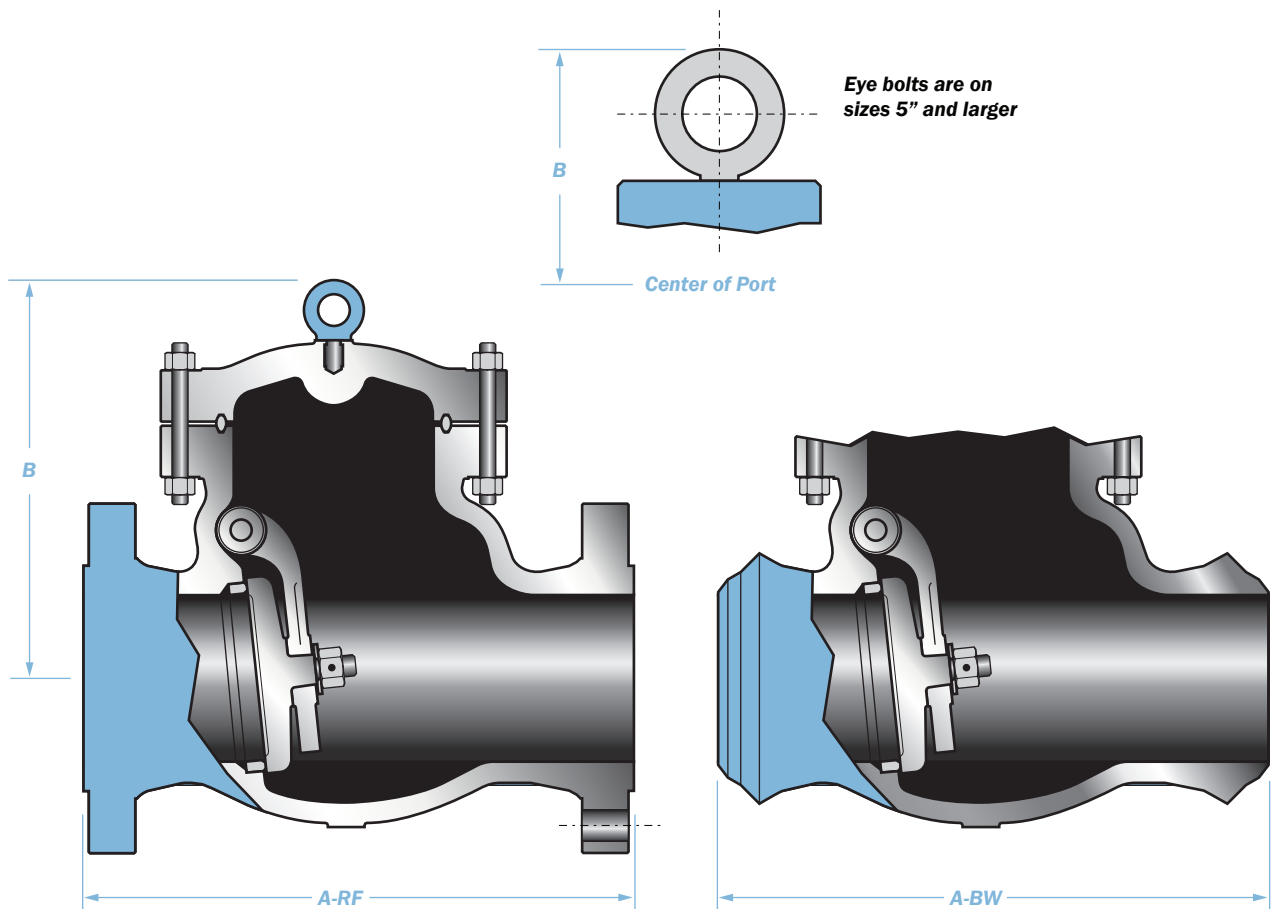



Typical Bill of Materials (See page 89 for available materials)			
Component	CB2	CB3	CB4/2
Body	ASTM A216-WCB		
Cover	ASTM A105N		
Disc 2" through 5"	ASTM A182-F6a	ASTM A182-F6a/HF	ASTM A182-F316
Disc 6" and larger	ASTM A216-WCB/13% Chrome	ASTM A216-WCB/HF	ASTM A216-WCB/316 Faced
Swing Arm	ASTM A216-WCB		
Seat Ring	ASTM A105/HF		
*Cover Gasket	Soft Steel Ring Joint		
Hinge Pin	ASTM A276-410		ASTM A276-316
Name Plate	304 Stainless Steel		
Washer	Stainless Steel		
Cover Bolt	ASTM A193-B7		ASTM A193-B7M
Cover Nut	ASTM A276-410		ASTM A276-316
Plug	AISI 1020		
Pin	ASTM A276-316		
Hex Nut	A194-8		
Eye Bolt 5" through 24"	Carbon Steel		

Class 600											
Size	NPS	2	2.5	3	4	5	6	8	10	12	14
	DN	50	75	100	150	125	150	200	250	300	350
A-RF	In	11.5	13.0	14.0	17.0	20.0	22.0	26.0	31.0	33.0	35.0
	mm	292	330	356	432	508	559	660	787	838	889
A-BW	In	11.5	13.0	14.0	17.0	20.0	22.0	26.0	31.0	33.0	35.0
	mm	292	330	356	432	508	559	660	787	838	889
B	In	7.8	8.8	9.7	13.3	15.5	16.8	19.4	22.6	25.4	26.4
	mm	198	224	246	338	394	427	493	574	645	671
RF Wt.	Lbs	65	90	115	215	348	481	926	1279	1722	2009
	Kg	30	41	52	98	159	219	421	581	783	913
BW Wt.	Lbs	51	68	91	161	255	349	762	1021	1411	1650
	Kg	23	31	41	73	116	159	346	483	641	750

**Note:** Dimensions: Inches/Millimeters - Weights: Pounds/Kilograms. Larger sizes available on request. Dimensions are subject to change without notice.

Styles: CB2, CB3 and CB4/2
Class: 900 - Sizes: 2" to 8"
Pressure Class Range: 150 to 1500

**Design and Manufacturing Standards**

Valve Design: ASME B16.34/API 600
Flange Dimensions: ASME B16.5, B16.47 (Series A)
Face to Face Dimensions: ASME B16.10
Tested in Accordance With: API 598
Recommended Spare Parts*

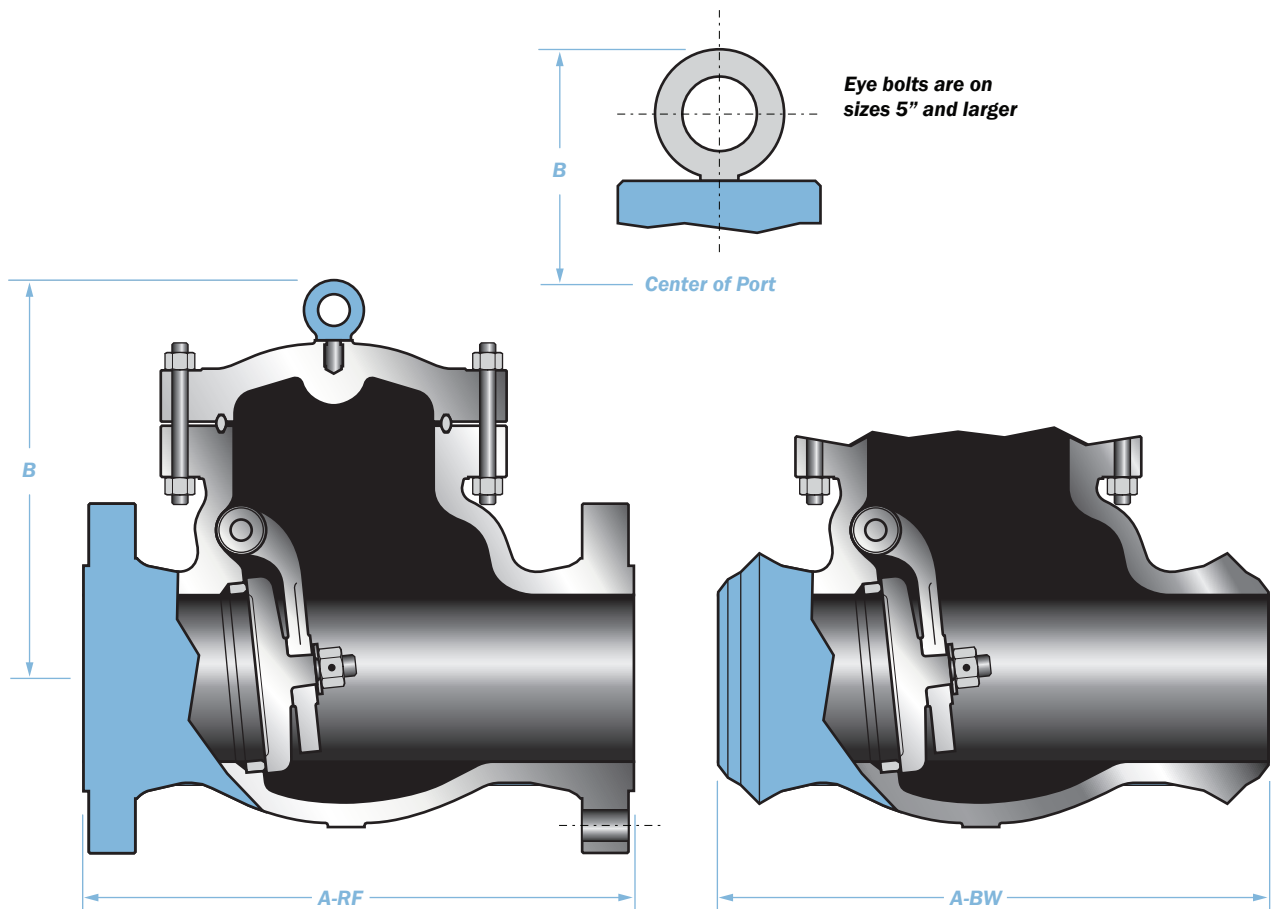

Typical Bill of Materials (See page 89 for available materials)			
Component	CB2	CB3	CB4/2
Body	ASTM A216-WCB		
Cover	ASTM A105N		
Disc 2" through 5"	ASTM A182-F6a	ASTM A182-F6a/HF	ASTM A182-F316
Disc 6" and larger	ASTM A216-WCB/13% Chrome	ASTM A216-WCB/HF	ASTM A216-WCB/316 Faced
Swing Arm	ASTM A216-WCB		
Seat Ring	ASTM A105/HF		
*Cover Gasket	Soft Steel Ring Joint		
Hinge Pin	ASTM A276-410		ASTM A276-316
Name Plate	304 Stainless Steel		
Washer	Stainless Steel		
Cover Bolt	ASTM A193-B7		ASTM A193-B7M
Cover Nut	ASTM A276-410		ASTM A276-316
Plug	AISI 1020		
Pin	ASTM A276-316		
Hex Nut	A194-8		
Eye Bolt 5" through 24"	Carbon Steel		

Class 900						
Size	NPS	2	3	4	6	8
	DN	50	75	100	150	200
A-RF	In	14.5	15.0	18.0	24.0	29.0
	mm	368	381	457	610	737
A-BW	In	14.5	15.0	18.0	24.0	29.0
	mm	368	381	457	610	737
B	In	13.1	14.8	14.5	18.8	23.6
	mm	329	329	368	478	599
RF Wt.	Lbs	104	184	344	770	1482
	Kg	47	84	156	350	674
BW Wt.	Lbs	78	138	258	578	1112
	Kg	35	63	129	263	505

**Note:** Dimensions: Inches/Millimeters - Weights: Pounds/Kilograms. Larger sizes available on request. Dimensions are subject to change without notice.

Styles: CB2, CB3 and CB4/2
Class: 1500 - Sizes: 2" to 8"
Pressure Class Range: 150 to 1500

**Design and Manufacturing Standards**

Valve Design: ASME B16.34/API 600
Flange Dimensions: ASME B16.5, B16.47 (Series A)
Face to Face Dimensions: ASME B16.10
Tested in Accordance With: API 598
Recommended Spare Parts*

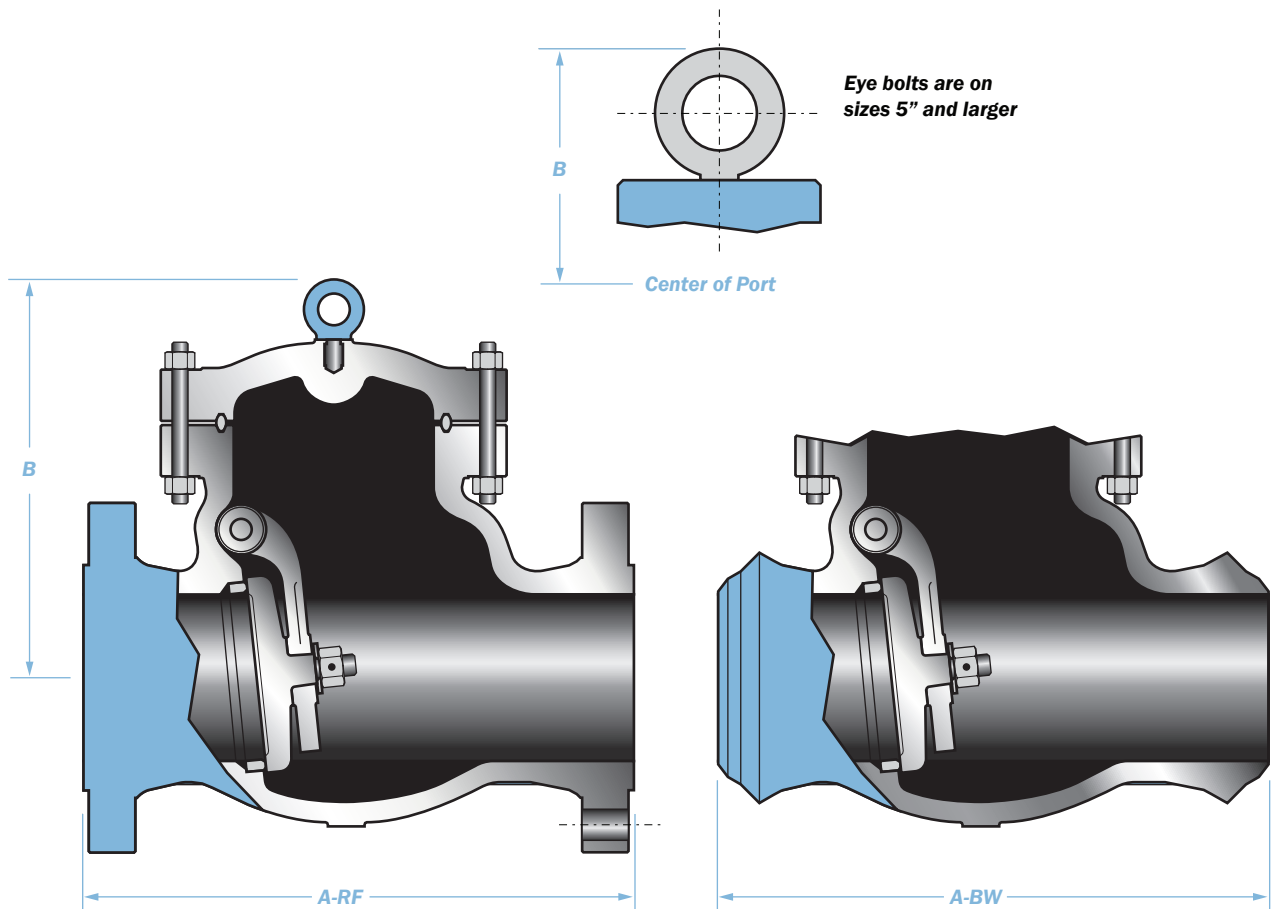

Typical Bill of Materials (See page 89 for available materials)			
Component	CB2	CB3	CB4/2
Body	ASTM A216-WCB		
Cover	ASTM A105N		
Disc 2" through 5"	ASTM A182-F6a	ASTM A182-F6a/HF	ASTM A182-F316
Disc 6" and larger	ASTM A216-WCB/13% Chrome	ASTM A216-WCB/HF	ASTM A216-WCB/316 Faced
Swing Arm	ASTM A216-WCB		
Seat Ring	ASTM A105/HF		
*Cover Gasket	Soft Steel Ring Joint		
Hinge Pin	ASTM A276-410		ASTM A276-316
Name Plate	304 Stainless Steel		
Washer	Stainless Steel		
Cover Bolt	ASTM A193-B7		ASTM A193-B7M
Cover Nut	ASTM A276-410		ASTM A276-316
Plug	AISI 1020		
Pin	ASTM A276-316		
Hex Nut	A194-8		
Eye Bolt 5" through 24"	Carbon Steel		

Class 1500							
Size	NPS	2	2.5	3	4	6	8
	DN	50	75	100	150	200	203
A-RF	In	14.5	16.5	18.5	21.5	27.8	32.8
	mm	368	419	470	546	706	833
A-BW	In	14.5	16.5	18.5	21.5	27.8	32.8
	mm	368	419	470	546	706	833
B	In	13.1	13.7	14.8	15.2	19.2	27.0
	mm	333	348	376	386	488	686
RF Wt.	Lbs	165	243	284	462	940	1030
	Kg	75	110	129	269	427	468
BW Wt.	Lbs	153	223	256	425	895	985
	Kg	70	101	116	193	407	448

**Note:** Dimensions: Inches/Millimeters - Weights: Pounds/Kilograms. Larger sizes available on request. Dimensions are subject to change without notice.

**V. CAST STEEL BOLTED COVER TILTING DISC CHECK VALVES**  
**SIZES: 2" TO 12" (50MM TO 300MM) • PRESSURE CLASS: 150 TO 300**  
(PRESSURE SEAL 600 TO 2500)

Typical Cast Steel Bolted Cover Tilting Disc Check Valve Expanded View

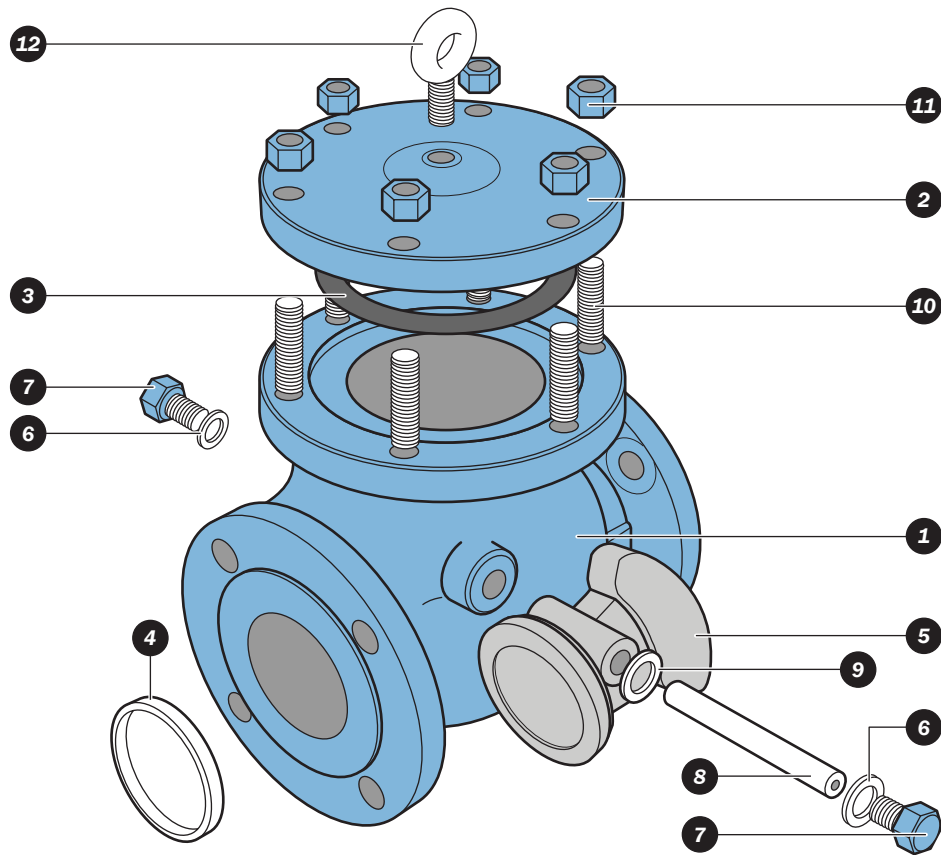

*Note: Classes 600 and larger use internal hinge pin.*

- 1. Body:** Cameron's NEWCO cast steel bodies provide low resistance flow and optimum strength and performance.
- 2. Cover:** The cover allows access to internal components.
- 3. Cover Gasket:** The cover gasket creates a leak-proof seal between the bonnet and body.
- 4. Seat Ring:** To ensure a stable shut-off, the seat ring is aligned and seal-welded into the valve, then precision ground for optimal seating.
- 5. Disc:** The disc allows unidirectional flow and restricts back flow with trouble free shut-off.
- 6. Plug Gasket:** The plug gasket creates a leak-proof seal between the plug and body.
- 7. Plug:** The disc nut and pin secures the disc to the arm.
- 8. Hinge Pin:** The hinge pin provides a stable mechanism for the disc to operate.
- 9. Hinge Pin Washer:** The hinge pin washer provides accurate disc positioning.
- 10. & 11. Cover Studs and Nuts:** The cover studs and nuts secure the bonnet to the body.
- 12. Eyebolt:** The eyebolt is used to aid in lifting the valve.

Styles: CB2, CB3 and CB4/2
Class: 150 - Sizes: 2.5" to 12"
Pressure Class Range: 150 to 300 (See Pressure Seal To 2500)

### Design and Manufacturing Standards

Valve Design: ASME B16.34/API 600
Flange Dimensions: ASME B16.5, B16.47 (Series A)
Face to Face Dimensions: ASME B16.10
Tested in Accordance With: API 598
Recommended Spare Parts*

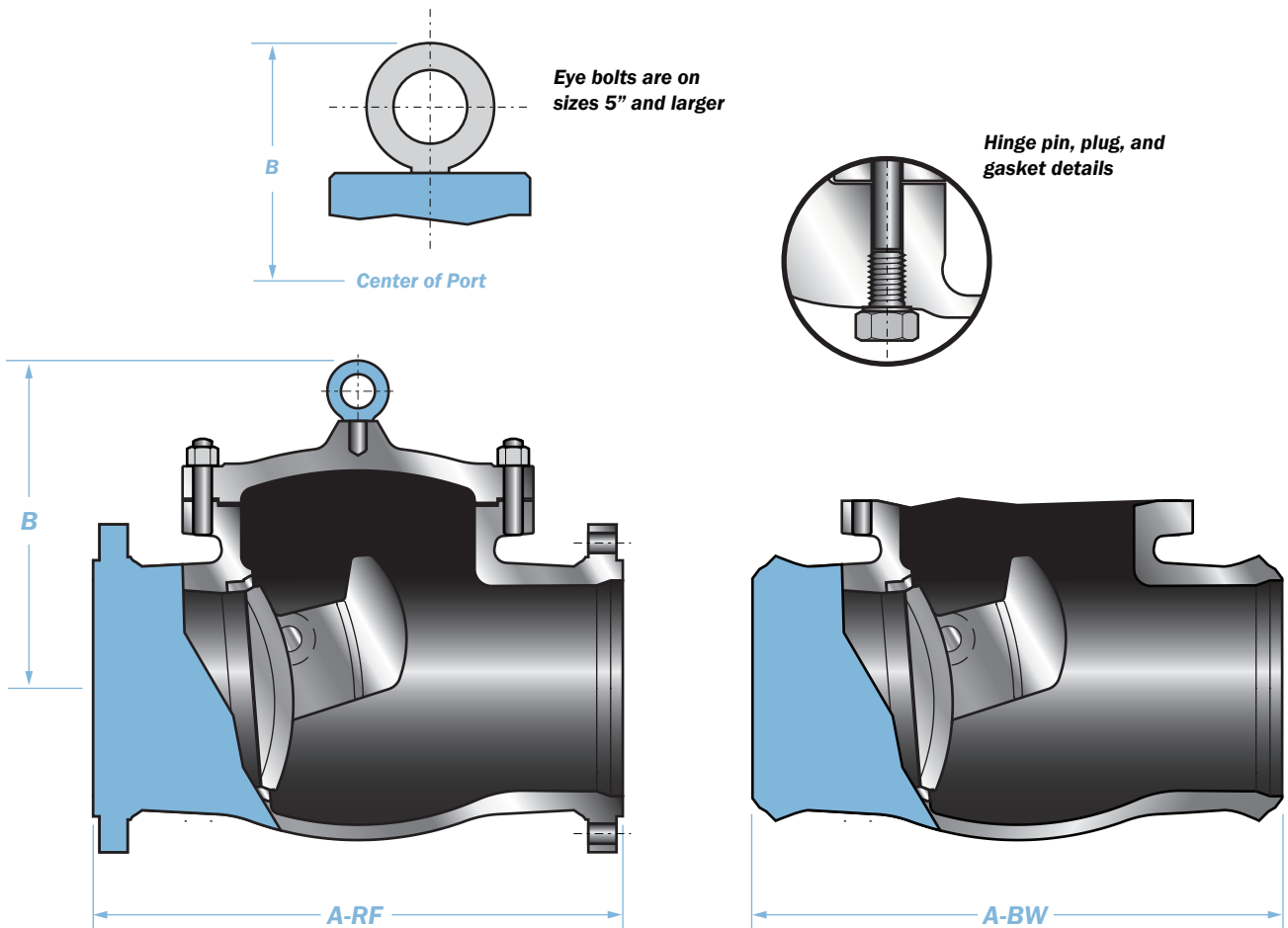



Typical Bill of Materials (See page 89 for available materials)			
Component	CB2	CB3	CB4/2
Body	ASTM A216-WCB		
Cover	ASTM A105/A216-WCB		
Disc	ASTM A216-WCB/13% Chrome	ASTM A216-WCB/HF	ASTM A182-F316/ ASTM A351-CF8M
Seat Ring	ASTM A105/HF		ASTM A182-F316/ ASTM A351-CF8M w/HF
*Cover Gasket	Spiral Wound 304 Stainless Steel/Graphite		
Hinge Pin	ASTM A479-410		
Hinge Pin Washer	ASTM A479-410		
Plug Gasket	304 Stainless Steel/Graphite		
Name Plate	304 Stainless Steel		
Cover Bolts	ASTM A193-B7		ASTM A193-B7M
Cover Nuts	ASTM A194-2H		ASTM A194-2HM
Plug	ASTM A105		
Eye Bolt 5" and larger	ASTM A108-1020		

Class 150								
Size	NPS	2.5	3	4	6	8	10	12
	DN	65	75	100	150	200	250	300
A-RF	In	8.5	9.5	11.5	14.0	19.5	24.5	27.5
	mm	216	241	292	356	495	622	699
A-BW	In	8.5	9.5	11.5	14.0	19.5	24.5	27.5
	mm	216	241	292	356	495	622	699
B	In	8.27	7.5	7.3	9.0	13.8	15.4	16.1
	mm	210	190	185	230	350	390	410
RF Wt.	Lbs	42	68	92	174	302	477	655
	Kg	92	150	202	383	664	1049	1441
BW Wt.	Lbs	30	50	78	136	244	376	464
	Kg	66	110	172	299	537	827	1021

**Note:** Dimensions: Inches/Millimeters - Weights: Pounds/Kilograms. Larger sizes available on request. Dimensions are subject to change without notice.

Styles: CB2, CB3 and CB4/2

Class: 300 - Sizes: 3" to 12"

Pressure Class Range: 150 to 300 (See Pressure Seal To 2500)

**Design and Manufacturing Standards**

Valve Design: ASME B16.34/API 600

Flange Dimensions: ASME B16.5, B16.47 (Series A)

Face to Face Dimensions: ASME B16.10

Tested in Accordance With: API 598

Recommended Spare Parts\*

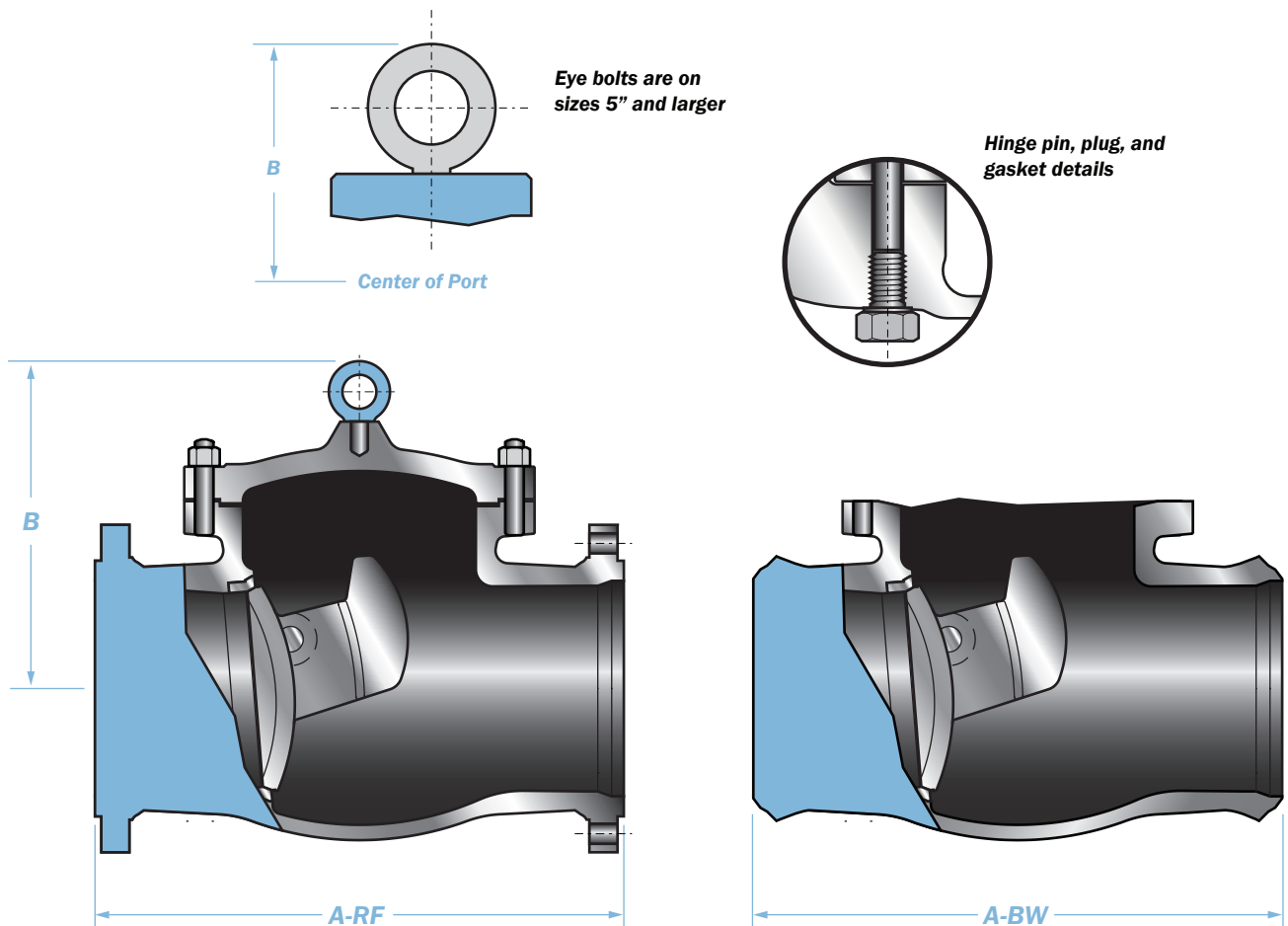

Typical Bill of Materials (See page 89 for available materials)			
Component	CB2	CB3	CB4/2
Body	ASTM A216-WCB		
Cover	ASTM A105/A216-WCB		
Disc	ASTM A216-WCB/13% Chrome	ASTM A216-WCB/HF	ASTM A182-F316/ ASTM A351-CF8M
Seat Ring	ASTM A105/HF		ASTM A182-F316/ ASTM A351-CF8M w/HF
*Cover Gasket	Spiral Wound 304 Stainless Steel/Graphite		
Hinge Pin	ASTM A479-410		
Hinge Pin Washer	ASTM A479-410		
Plug Gasket	304 Stainless Steel/Graphite		
Name Plate	304 Stainless Steel		
Cover Bolts	ASTM A193-B7		ASTM A193-B7M
Cover Nuts	ASTM A194-2H		ASTM A194-2HM
Plug	ASTM A105		
Eye Bolt 5" and larger	ASTM A108-1020		

Class 300							
Size	NPS	3	4	6	8	10	12
	DN	75	100	150	200	250	300
A-RF	In	12.5	14.0	17.5	21.0	24.5	28.0
	mm	318	356	444	533	622	711
A-BW	In	12.5	14.0	17.5	21.0	24.5	28.0
	mm	318	356	444	533	622	711
B	In	6.5	7.3	8.8	13.4	15.2	17.7
	mm	165	185	224	340	385	450
RF Wt.	Lbs	82	122	252	386	568	818
	Kg	180	268	554	849	1250	1800
BW Wt.	Lbs	57	78	168	278	458	690
	Kg	125	172	370	612	1008	1518

**Note:** Dimensions: Inches/Millimeters - Weights: Pounds/Kilograms. Larger sizes available on request. Dimensions are subject to change without notice.

## VI. CAST STEEL BOLTED BONNET STOP CHECK VALVES SIZES: 2" TO 14" (50MM TO 350MM) • PRESSURE CLASS: 150 TO 1500

Typical Cast Steel Bolted Bonnet Stop Check Valve Expanded View

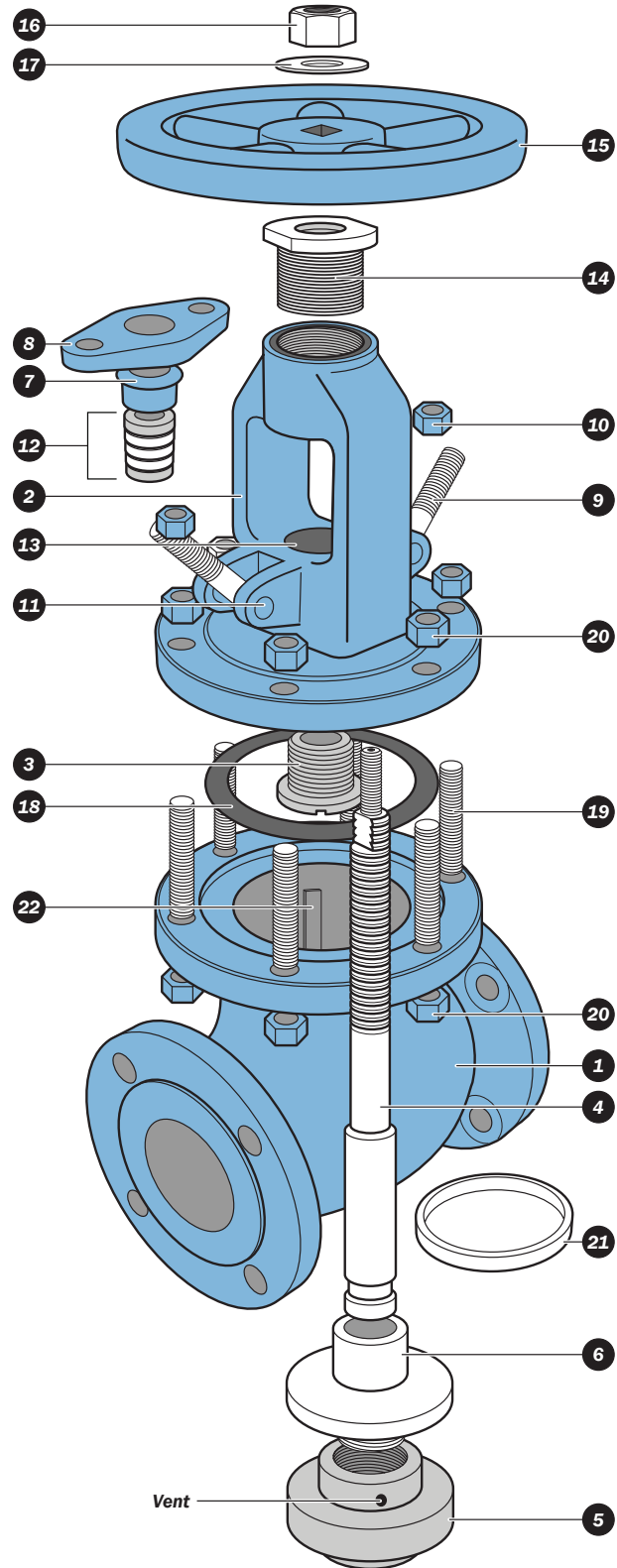

1. **Body:** Cameron's NEWCO cast steel bodies provide low resistance flow and optimum strength and performance.
2. **Bonnet:** Cameron's NEWCO bonnet assemblies are built to the same standards as the bodies.
3. **Back Seat:** The back seat, when engaged with the stem head, provides a stable shut-off to the stuffing box which isolates the packing from flow exposure.
4. **Stem:** The stem inserts vertically into the disc.
5. **Disc:** The 1-piece vented disc is machined to the tightest tolerance to ensure trouble free shut-off and cycling.
6. **Disc Nut:** The disc nut serves as a mechanical guide acting on the stem to ensure proper alignment of the disc to the seat.
7. **Gland:** The gland compresses the packing to create a stem seal above the back seat between the bonnet and stem.
8. **Gland Flange:** The gland flange applies pressure to the gland for accurate packing adjustments.
9. & 10. **Gland Bolts and Nuts:** The gland bolts and nuts allow for easy adjustments for packing compression.
11. **Gland Bolt Pin:** The gland bolt pin secures the gland bolts to the yoke and bonnet.
12. **Packing:** The packing creates a seal above the back seat between the bonnet and stem.
13. **Stuffing Box:** The stuffing box contains the packing.
14. **Stem Nut:** The stem nut provides a precision guide for proper stem alignment.
15. **Handwheel:** The handwheel cycles the valve.
16. **Handwheel Nut:** The handwheel nut secures the handwheel to the bonnet assembly.
17. **Handwheel Washer:** The washer helps to prevent loosening or distributes pressure evenly.
18. **Bonnet Gasket:** The bonnet gasket creates a leakproof seal between the bonnet and body.
19. & 20. **Bonnet Studs and Nuts:** The bonnet studs and nuts secure the bonnet to the body.
21. **Seat Ring:** To ensure a stable shut-off, the seat ring is aligned and seal-welded into the valve, then precision ground for optimal seating.
22. **Disc Guide:** The disc guides provide a stable track for keeping the disc aligned with the seat during cycling.

Styles: CB2, CB3 and CB4/2
Class: 150 - Sizes: 2" to 14"
Pressure Class Range: 150 to 1500

**Design and Manufacturing Standards**

Valve Design: ASME B16.34/API 600
Flange Dimensions: ASME B16.5, B16.47 (Series A)
Face to Face Dimensions: ASME B16.10
Tested in Accordance With: API 598
Recommended Spare Parts*

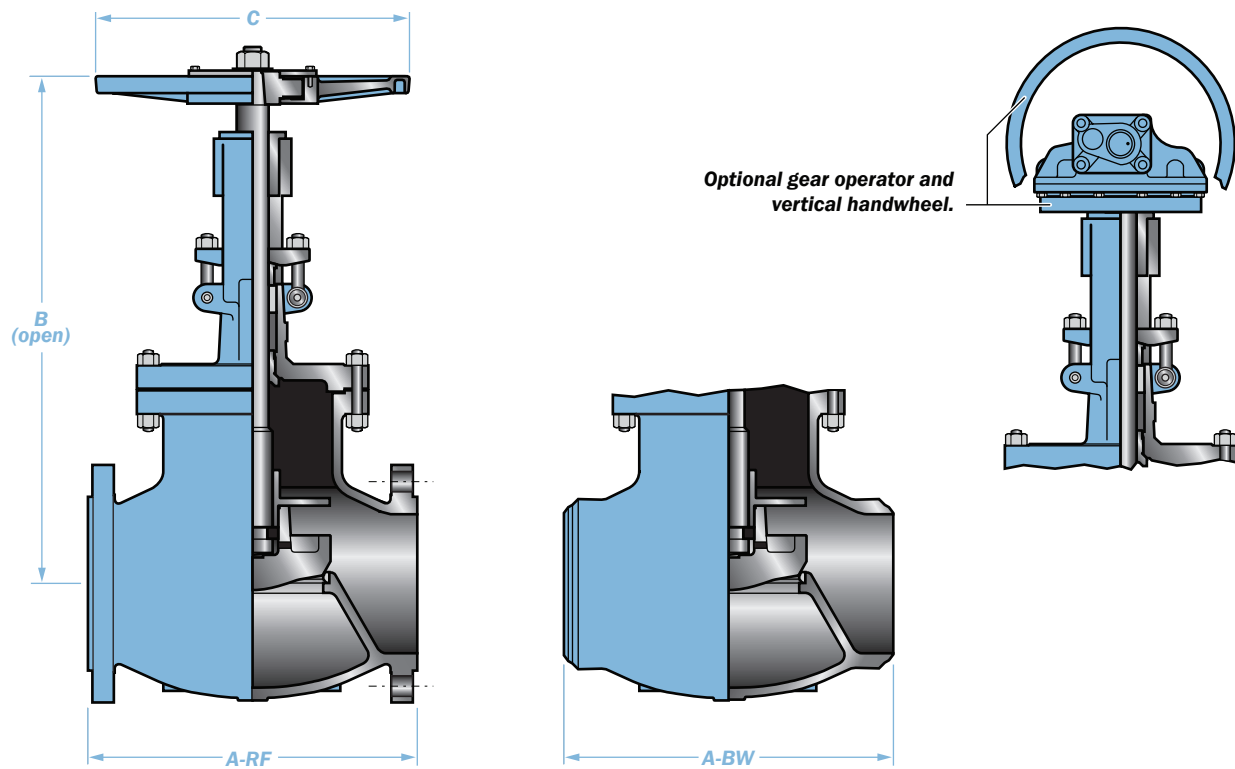

Typical Bill of Materials (See page 89 for available materials)

Component	CB2	CB3	CB4/2
Body	ASTM A216-WCB		
Disc 2" through 4"	ASTM A276-410	ASTM A216-WCB/HF	ASTM A276-316
Disc 5" and larger	ASTM A216-WCB/13% Chrome		ASTM A216-WCB/316
Stem	ASTM A276-410		ASTM A276-316
Bonnet	ASTM A216-WCB		
*Bonnet Gasket	Spiral Wound 316 Stainless Steel/Graphite		
Bonnet Nuts	ASTM A194-2H		ASTM A194-2HM
Bonnet Studs	ASTM 193-B7		ASTM A193-B7M
Back Seat Bushing	ASTM A276-410		ASTM A276-316
*Packing	Graphite W/Braided Carbon Fiber End Rings		
Gland	ASTM A276-410		ASTM A276-316
Gland Flange	ASTM A276-WCB		
Gland Bolt Pins	ASTM A36		
Gland Nuts	ASTM A194-2H		ASTM A194-2HM
Gland Bolts	ASTM A307-B		ASTM A193-B7M
Seat Ring	ASTM A105/HF**		
Split Ring	N/A		
Nameplate	ASTM A666-304		
Nameplate Rivets	Commercial		
Disc Nut	ASTM A276-410		ASTM A276-316
Stem Nut	ASTM A439-D2		
Handwheel Washer	ASTM A36		
Handwheel Nut	ASTM A36		
Handwheel	ASTM A536 (65-45-12)		
Spacer Ring	N/A		

Class 150

Size	NPS	2	2.5	3	4	5	6	8	10	12	14
	DN	50	75	100	150	125	150	200	250	300	350
A-RF	In	8.0	8.5	9.5	11.5	14.0	16.0	19.5	24.5	27.5	31.0
	mm	203	216	241	292	356	406	495	622	699	787
A-BW	In	8.0	8.5	9.5	11.5	14.0	16.0	19.5	24.5	27.5	31.0
	mm	203	216	241	292	356	406	495	622	699	787
B	In	14.9	15.8	16.6	19.9	21.8	22.4	26.5	30.6	34.8	41.4
	mm	378	401	422	505	554	569	673	777	884	1052
C	In	8.0	10.0	10.0	12.0	14.0	16.0	18.0	22.0	24.0	25.2
	mm	203	254	254	305	356	406	457	559	610	640
RF Wt.	Lbs	51	73	93	137	192	243	419	507	948	1276
	Kg	23	33	42	62	87	110	190	276	476	625
BW Wt.	Lbs	51	73	93	137	192	243	419	507	948	1276
	Kg	23	33	42	62	87	110	190	276	476	625

**Note:** Dimensions: Inches/Millimeters - Weights: Pounds/Kilograms. Larger sizes available on request. Dimensions are subject to change without notice.

\*\* Integral seat w/HF for sizes 2" to 4".

Styles: CB2, CB3 and CB4/2
Class: 300 - Sizes: 2" to 14"
Pressure Class Range: 150 to 1500

<b>Design and Manufacturing Standards</b>
---

Valve Design: ASME B16.34/API 600
Flange Dimensions: ASME B16.5, B16.47 (Series A)
Face to Face Dimensions: ASME B16.10
Tested in Accordance With: API 598
Recommended Spare Parts*

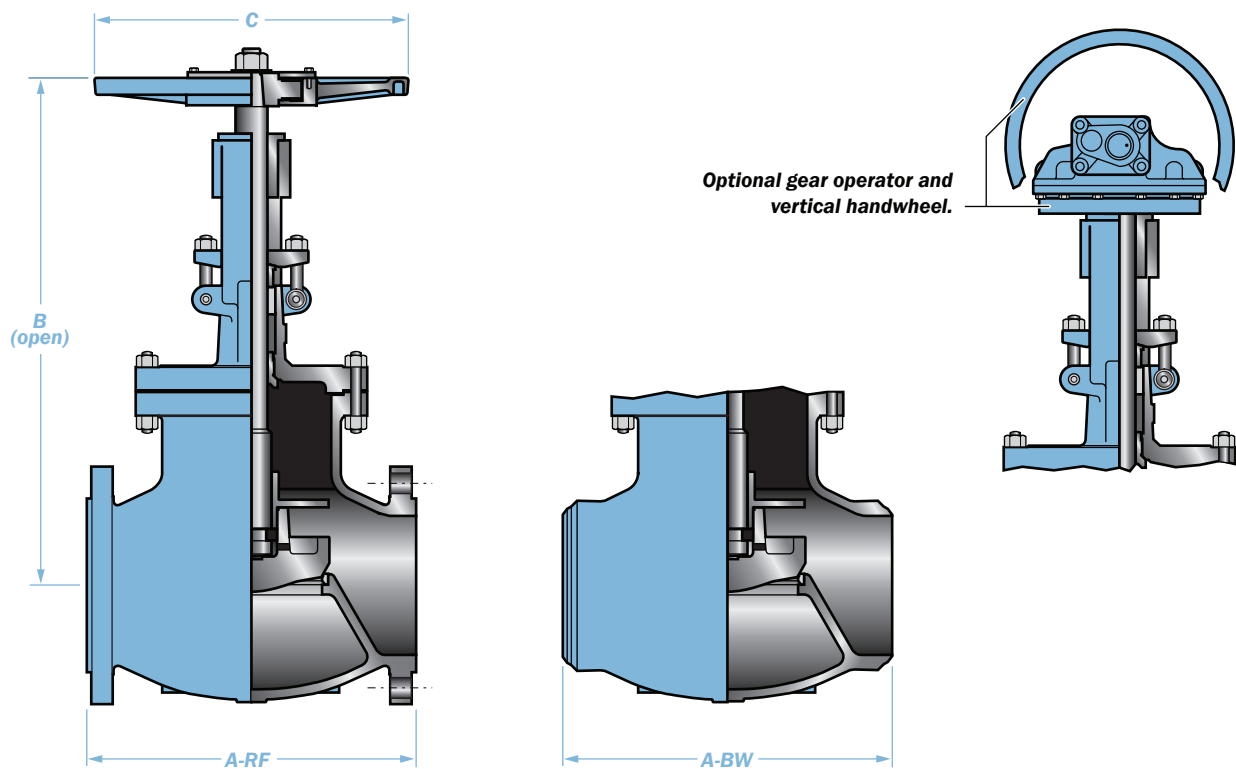



Typical Bill of Materials (See page 89 for available materials)			
Component	CB2	CB3	CB4/2
Body	ASTM A216-WCB		
Disc 2" through 4"	ASTM A276-410	ASTM A216-WCB/HF	ASTM A276-316
Disc 5" and larger	ASTM A216-WCB/13% Chrome		ASTM A216-WCB/316
Stem	ASTM A276-410		ASTM A276-316
Bonnet	ASTM A216-WCB		
*Bonnet Gasket	Spiral Wound 316 Stainless Steel/Graphite		
Bonnet Nuts	ASTM A194-2H		ASTM A194-2HM
Bonnet Studs	ASTM 193-B7		ASTM A193-B7M
Back Seat Bushing	ASTM A276-410		ASTM A276-316
*Packing	Graphite W/Braided Carbon Fiber End Rings		
Gland	ASTM A276-410		ASTM A276-316
Gland Flange	ASTM A276-WCB		
Gland Bolt Pins	ASTM A36		
Gland Nuts	ASTM A194-2H		ASTM A194-2HM
Gland Bolts	ASTM A307-B		ASTM A193-B7M
Seat Ring	ASTM A105/HF**		
Split Ring	N/A		
Nameplate	ASTM A666-304		
Nameplate Rivets	Commercial		
Disc Nut	ASTM A276-410		ASTM A276-316
Stem Nut	ASTM A439-D2		
Handwheel Washer	ASTM A36		
Handwheel Nut	ASTM A36		
Handwheel	ASTM A536 (65-45-12)		
Spacer Ring	N/A		

Class 300											
Size	NPS	2	2.5	3	4	5	6	8	10	12	14
	DN	50	75	100	150	125	150	200	250	300	350
A-RF	In	10.5	11.5	12.5	14.0	15.75	17.5	22.0	24.5	28.0	33.0
	mm	267	292	318	357	400	445	559	622	711	838
A-BW	In	10.5	11.5	12.5	14.0	15.75	17.5	22.0	24.5	28.0	33.0
	mm	267	292	318	357	400	445	559	622	711	838
B	In	16.9	17.8	19.2	23.0	27.4	30.6	36.2	40.8	47.3	54.3
	mm	429	452	488	584	696	777	919	1036	1201	1379
C	In	10.0	10.0	12.0	14.0	14.0	18.0	24.0	24.0	27.0	28.3
	mm	254	254	305	356	406	457	610	610	686	720
RF Wt.	Lbs	75.0	100.0	130.0	203.0	294.0	421.0	715	1015	1500	2446
	Kg	34	45	59	92	134	191	325	461	682	1112
BW Wt.	Lbs	55	79	101	163	242	355	566	770	1218	1996
	Kg	25	36	46	74	110	161	257	350	554	907

**Note:** Dimensions: Inches/Millimeters - Weights: Pounds/Kilograms. Larger sizes available on request. Dimensions are subject to change without notice.

\*\* Integral seat w/HF for sizes 2" to 4".

Styles: CB2, CB3 and CB4/2

Class: 600 - Sizes: 2" to 8"

Pressure Class Range: 150 to 1500

**Design and Manufacturing Standards**

Valve Design: ASME B16.34/API 600

Flange Dimensions: ASME B16.5, B16.47 (Series A)

Face to Face Dimensions: ASME B16.10

Tested in Accordance With: API 598

Recommended Spare Parts\*

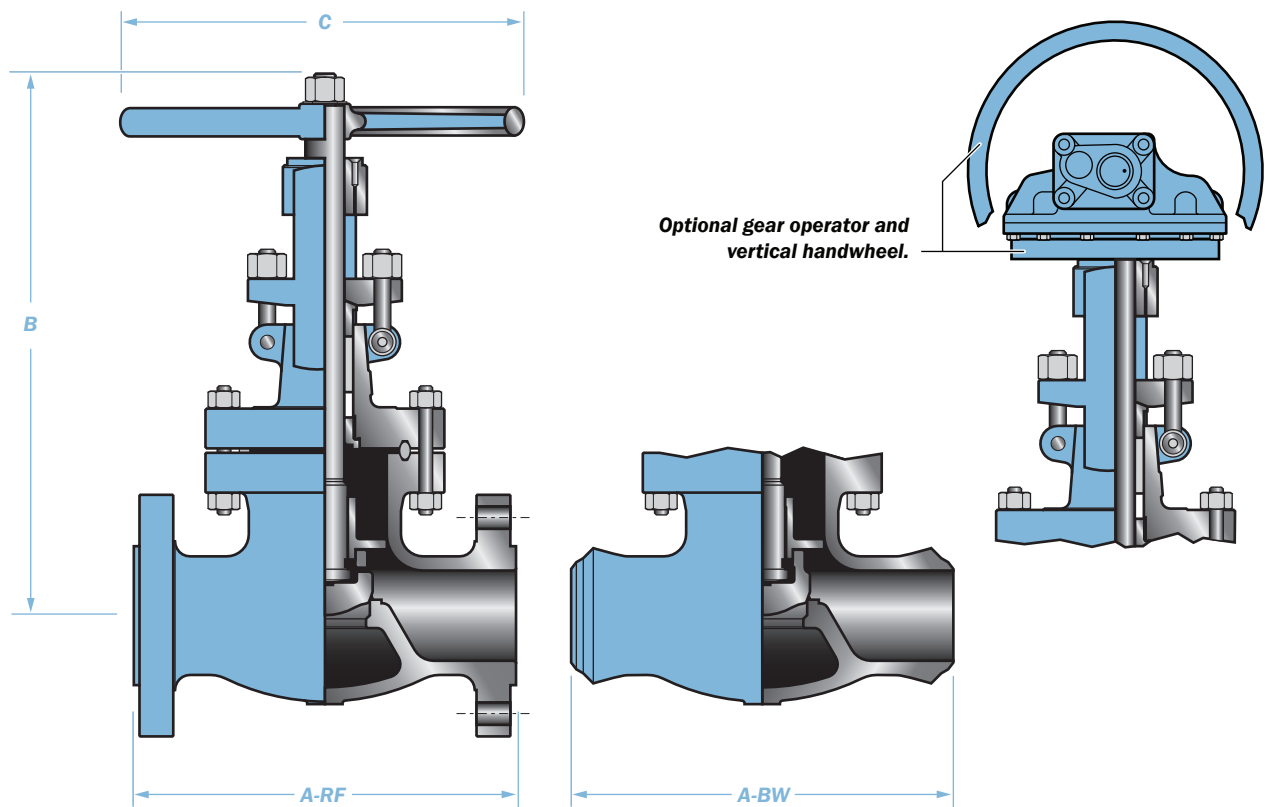

Typical Bill of Materials (See page 89 for available materials)			
Component	CB2	CB3	CB4/2
Body	ASTM A216-WCB		
Disc 2" through 4"	ASTM A276-410	ASTM A216-WCB/HF	ASTM A276-316
Disc 5" and larger	ASTM A216-WCB/13% Chrome		ASTM A216-WCB/316
Stem	ASTM A276-410		ASTM A276-316
Bonnet	ASTM A216-WCB		
*Bonnet Gasket	Soft Steel Ring Joint		
Bonnet Nuts	ASTM A194-2H		ASTM A194-2HM
Bonnet Studs	ASTM 193-B7		ASTM A193-B7M
Back Seat Bushing	ASTM A276-410		ASTM A276-316
*Packing	Graphite W/Braided Carbon Fiber End Rings		
Gland	ASTM A276-410		ASTM A276-316
Gland Flange	ASTM A276-WCB		
Gland Bolt Pins	ASTM A36		
Gland Nuts	ASTM A194-2H		ASTM A194-2HM
Gland Bolts	ASTM A307-B		ASTM A193-B7M
Seat Ring	Integral ASTM A216 WCB/HF		
Split Ring	N/A		
Nameplate	ASTM A666-304		
Nameplate Rivets	Commercial		
Disc Nut	ASTM A276-410		ASTM A276-316
Stem Nut	ASTM A439-D2		
Handwheel Washer	ASTM A36		
Handwheel Nut	ASTM A36		
Handwheel	ASTM A536 (65-45-12)		
Spacer Ring	ASTM A276-410		

Class 600							
Size	NPS	2	2.5	3	4	6	8
	DN	50	75	100	150	200	203
A-RF	In	11.5	13.0	14.0	17.0	22.0	26.0
	mm	292	325	256	435	559	660
A-BW	In	11.5	13.0	14.0	17.0	22.0	26.0
	mm	292	325	256	435	559	660
B	In	18.4	20.0	24.4	29.0	37.9	44.7
	mm	467	508	620	737	963	1135
C	In	10.0	10.0	14.0	18.0	24.0	24.0
	mm	254	254	356	457	610	610
RF Wt.	Lbs	90	130	170	313	778	1245
	Kg	41	59	77	142	354	566
BW Wt.	Lbs	79	110	141	256	640	961
	Kg	36	50	64	116	291	437

**Note:** Dimensions: Inches/Millimeters - Weights: Pounds/Kilograms. Larger sizes available on request. Dimensions are subject to change without notice.

Styles: CB2, CB3 and CB4/2

Class: 900 - Sizes: 2" to 8"

Pressure Class Range: 150 to 1500

**Design and Manufacturing Standards**

Valve Design: ASME B16.34/API 600

Flange Dimensions: ASME B16.5, B16.47 (Series A)

Face to Face Dimensions: ASME B16.10

Tested in Accordance With: API 598

Recommended Spare Parts\*

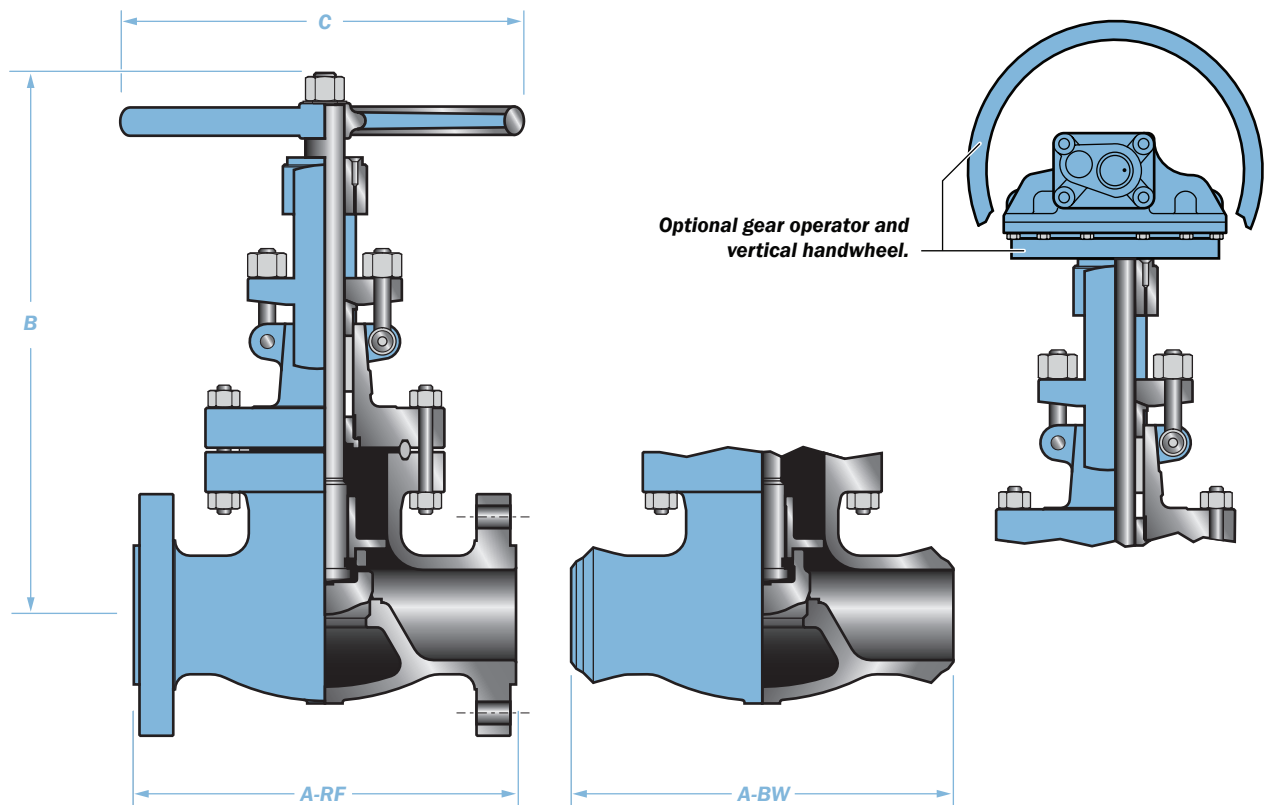

Typical Bill of Materials (See page 89 for available materials)			
Component	CB2	CB3	CB4/2
Body	ASTM A216-WCB		
Disc 2" through 4"	ASTM A276-410	ASTM A216-WCB/HF	ASTM A276-316
Disc 5" and larger	ASTM A216-WCB/13% Chrome		ASTM A216-WCB/316
Stem	ASTM A276-410		ASTM A276-316
Bonnet	ASTM A216-WCB		
*Bonnet Gasket	Soft Steel Ring Joint		
Bonnet Nuts	ASTM A194-2H		ASTM A194-2HM
Bonnet Studs	ASTM 193-B7		ASTM A193-B7M
Back Seat Bushing	ASTM A276-410		ASTM A276-316
*Packing	Graphite W/Braided Carbon Fiber End Rings		
Gland	ASTM A276-410		ASTM A276-316
Gland Flange	ASTM A276-WCB		
Gland Bolt Pins	ASTM A36		
Gland Nuts	ASTM A194-2H		ASTM A194-2HM
Gland Bolts	ASTM A307-B		ASTM A193-B7M
Seat Ring	Integral ASTM A216 WCB/HF		
Split Ring	N/A		
Nameplate	ASTM A666-304		
Nameplate Rivets	Commercial		
Disc Nut	ASTM A276-410		ASTM A276-316
Stem Nut	ASTM A439-D2		
Handwheel Washer	ASTM A36		
Handwheel Nut	ASTM A36		
Handwheel	ASTM A536 (65-45-12)		
Spacer Ring	ASTM A276-410		

Class 900						
Size	NPS	2	3	4	6	8
	DN	50	75	100	150	200
A-RF	In	14.5	15.0	18.0	24.0	29.0
	mm	368	381	457	610	737
A-BW	In	14.5	15.0	18.0	24.0	29.0
	mm	368	381	457	610	737
B	In	22.6	26.0	30.6	39.6	60.1
	mm	574	660	777	1006	1527
C	In	13.8	17.7	17.7	22.0	28.3
	mm	350	450	450	560	720
RF Wt.	Lbs	198	335	440	1675	2090
	Kg	90	152	200	761	950
BW Wt.	Lbs	176	297	376	1144	1634
	Kg	80	135	171	520	743

**Note:** Dimensions: Inches/Millimeters - Weights: Pounds/Kilograms. Larger sizes available on request. Dimensions are subject to change without notice.

Styles: CB2, CB3 and CB4/2

Class: 1500 - Sizes: 2" to 8"

Pressure Class Range: 150 to 1500

**Design and Manufacturing Standards**

Valve Design: ASME B16.34/API 600

Flange Dimensions: ASME B16.5, B16.47 (Series A)

Face to Face Dimensions: ASME B16.10

Tested in Accordance With: API 598

Recommended Spare Parts\*

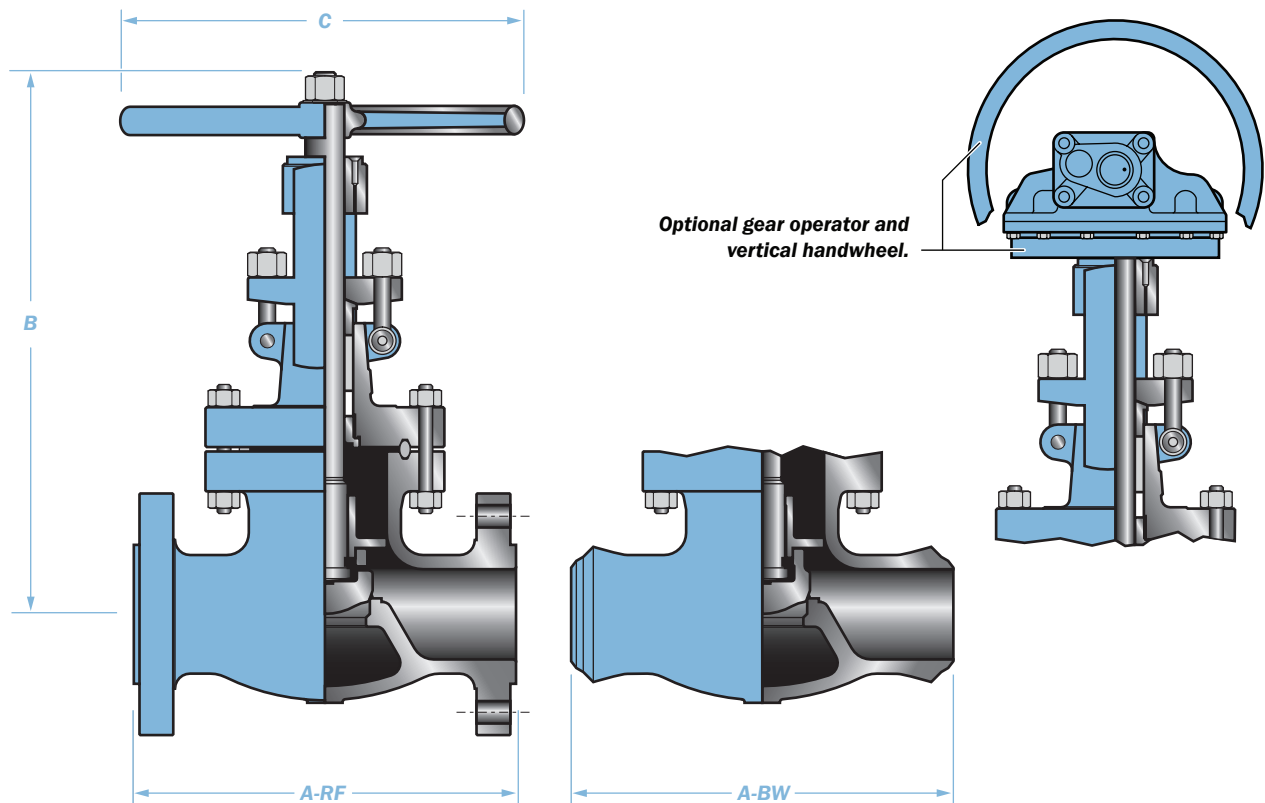

Typical Bill of Materials (See page 89 for available materials)			
Component	CB2	CB3	CB4/2
Body	ASTM A216-WCB		
Disc 2" through 4"	ASTM A276-410	ASTM A216-WCB/HF	ASTM A276-316
Disc 5" and larger	ASTM A216-WCB/13% Chrome		ASTM A216-WCB/316
Stem	ASTM A276-410		ASTM A276-316
Bonnet	A216-WCB		
*Bonnet Gasket	Soft Steel Ring Joint		
Bonnet Nuts	ASTM A194-2H		ASTM A194-2HM
Bonnet Studs	ASTM 193-B7		ASTM A193-B7M
Back Seat Bushing	ASTM A276-410		ASTM A276-316
*Packing	Graphite W/Braided Carbon Fiber End Rings		
Gland	ASTM A276-410		ASTM A276-316
Gland Flange	ASTM A276-WCB		
Gland Bolt Pins	ASTM A36		
Gland Nuts	ASTM A194-2H		ASTM A194-2HM
Gland Bolts	ASTM A307-B		ASTM A193-B7M
Seat Ring	Integral ASTM A216 WCB/HF		
Split Ring	N/A		
Nameplate	ASTM A666-304		
Nameplate Rivets	Commercial		
Disc Nut	ASTM A276-410		ASTM A276-316
Stem Nut	ASTM A439-D2		
Handwheel Washer	ASTM A36		
Handwheel Nut	ASTM A36		
Handwheel	ASTM A536 (65-45-12)		
Spacer Ring	ASTM A276-410		

Class 1500					
Size	NPS	2	3	4	6
	DN	50	75	100	150
A-RF	In	14.5	18.5	21.5	27.75
	mm	368	470	546	705
A-BW	In	14.5	18.5	21.5	27.75
	mm	368	470	546	705
B	In	19.6	25.6	30.8	36.5
	mm	498	650	782	927
C	In	13.8	17.7	19.7	25.2
	mm	350	450	500	640
RF Wt.	Lbs	209	551	959	1191
	Kg	95	250	436	541
BW Wt.	Lbs	143	460	830	996
	Kg	65	209	377	453

**Note:** Dimensions: Inches/Millimeters - Weights: Pounds/Kilograms. Larger sizes available on request. Dimensions are subject to change without notice.

**VII. CAST STEEL BOLTED BONNET ANGLE STOP CHECK VALVES  
SIZES: 2" TO 12" (50MM TO 300MM) • PRESSURE CLASS: 150 TO 600**

Typical Cast Steel Bolted Bonnet Angle Stop Check Valve Expanded View

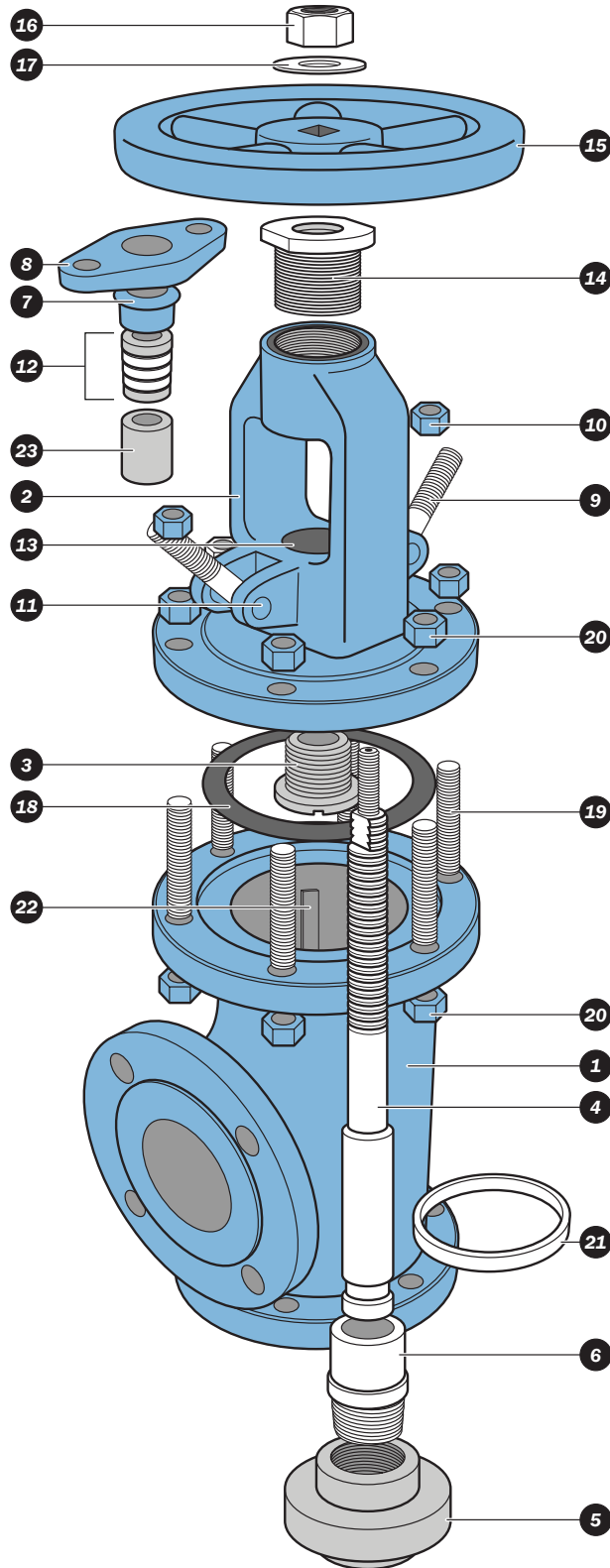



1. **Body:** Cameron's NEWCO cast steel bodies provide low resistance flow and optimum strength and performance.
2. **Bonnet:** Cameron's NEWCO bonnet assemblies are built to the same standards as the bodies.
3. **Back Seat Bushing:** The back seat, when engaged with the stem head, provides a stable shut-off to the stuffing box which isolates the packing from flow exposure.
4. **Stem:** The stem inserts vertically into the disc.
5. **Disc:** The 1-piece disc is machined to the tightest tolerance to ensure trouble free shut-off and cycling.
6. **Disc Nut:** The disc nut serves as a mechanical guide acting on the stem to ensure proper alignment of the disc to the seat.
7. **Gland:** The gland compresses the packing to create a stem seal above the back seat between the bonnet and stem.
8. **Gland Flange:** The gland flange applies pressure to the gland for accurate packing adjustments.
9. & 10. **Gland Bolts and Nuts:** The gland bolts and nuts allow for easy adjustments for packing compression.
11. **Gland Bolt Pin:** The gland bolt pin secures the gland bolts to the yoke and bonnet.
12. **Packing:** The packing creates a seal above the back seat between the bonnet and stem.
13. **Stuffing Box:** The stuffing box contains the packing.
14. **Stem Nut:** The stem nut provides a precision guide for proper stem alignment.
15. **Handwheel:** The handwheel cycles the valve.
16. **Handwheel Nut:** The handwheel nut secures the handwheel to the bonnet assembly.
17. **Handwheel Washer:** The washer helps to prevent loosening or distributes pressure evenly.
18. **Bonnet Gasket:** The bonnet gasket creates a leakproof seal between the bonnet and body.
19. & 20. **Bonnet Studs and Nuts:** The bonnet studs and nuts secure the bonnet to the body.
21. **Seat Ring:** To ensure a stable shut-off, the seat ring is aligned and seal-welded into the valve, then precision ground for optimal seating.
22. **Disc Guide:** The disc guides provide a stable track for keeping the disc aligned with the seat during cycling.
23. **Spacer Ring:** The spacer ring assists the packing rings in creating a seal above the back seat between the bonnet and stem.

Styles: CB2, CB3 and CB4/2

Class: 150 - Sizes: 2" to 12"

Pressure Class Range: 150 to 600

**Design and Manufacturing Standards**

Valve Design: ASME B16.34/API 600

Flange Dimensions: ASME B16.5, B16.47 (Series A)

Face to Face Dimensions: ASME B16.10

Tested in Accordance With: API 598

Recommended Spare Parts\*

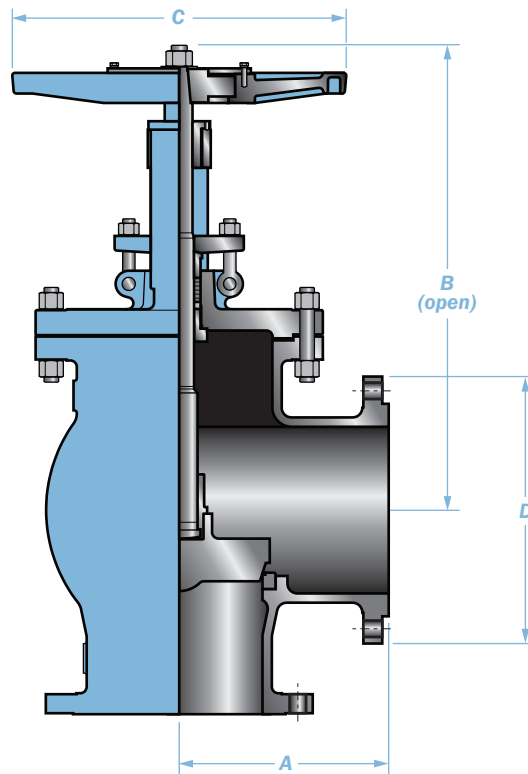

Typical Bill of Materials (See page 89 for available materials)			
Component	CB2	CB3	CB4/2
Body	ASTM A216 GR.WCB		
Seat Ring	ASTM A105/HF		
Disc 2" through 4"	ASTM A276-410	ASTM A216-WCB/HF	ASTM A276-316
Disc 5" and larger	ASTM A216-WCB/13% Chrome		ASTM A216-WCB/316
Disc Nut	ASTM A276-410		ASTM A276-316
Stem	ASTM A276-410		ASTM A276-316
*Bonnet Gasket	Spiral Wound 316 Stainless Steel/Graphite		
Bonnet	ASTM A216-WCB		
Bonnet Studs	ASTM 193-B7		ASTM A193-B7M
Bonnet Nuts	ASTM A194-2H		ASTM A194-2HM
Back Seat Bushing	ASTM A276-410		ASTM A276-316
Packing	Graphite w/Braided Carbon Fiber End Rings		
Gland Bolt Pins	ASTM A36		
Gland Bolts	ASTM 193-B7		ASTM A193-B7M
Gland	ASTM A276-410		ASTM A276-316
Gland Flange	ASTM A216-WCB		
Gland Nuts	ASTM A194-2H		ASTM A194-2HM
Stem Nut	ASTM A439-D2		
Split Ring	ASTM A276-410		
Handwheel Washer	ASTM A36		
Handwheel Nut	ASTM A36		
Handwheel	ASTM A539 Type (65-45-12)		
Spacer Ring	ASTM A276-410		ASTM A276-316

Class 150								
Size	NPS	2	3	4	6	8	10	12
	DN	50	75	100	150	200	250	300
A	In	4.0	4.75	5.75	8.0	9.75	12.25	13.75
	mm	107	121	146	203	248	311	349
B	In	15.2	16.9	20.4	21.8	27.4	31	37.8
	mm	386	429	518	554	696	787	960
C	In	8	10	12	15	18	22	24
	mm	203	254	305	381	457	559	610
D	In	6	7.5	9	11	13.5	16	19
	mm	152	191	229	279	343	406	483
RF Wt.	Lbs	57	84	141	234	399	611	794
	Kg	26	38	64	106	181	278	361

**Note:** Dimensions: Inches/Millimeters - Weights: Pounds/Kilograms. Larger sizes available on request. Dimensions are subject to change without notice.

Styles: CB2, CB3 and CB4/2

Class: 300 - Sizes: 2" to 12"

Pressure Class Range: 150 to 600

#### Design and Manufacturing Standards

Valve Design: ASME B16.34/API 600

Flange Dimensions: ASME B16.5, B16.47 (Series A)

Face to Face Dimensions: ASME B16.10

Tested in Accordance With: API 598

Recommended Spare Parts\*

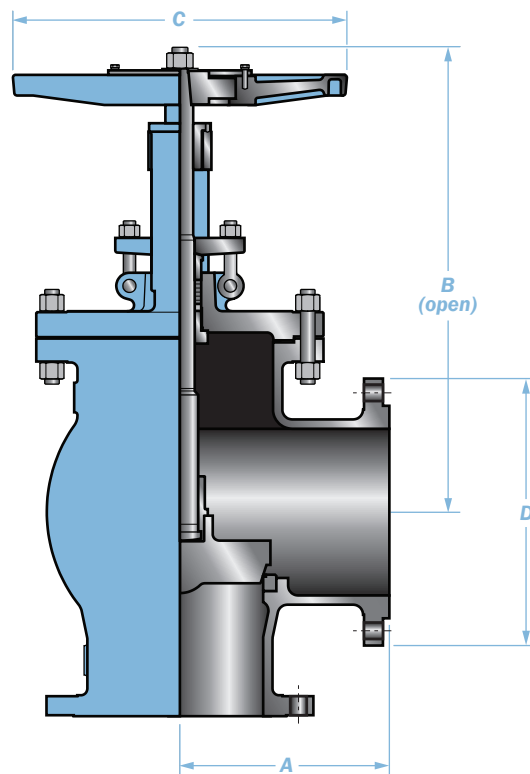

Typical Bill of Materials (See page 89 for available materials)			
Component	CB2	CB3	CB4/2
Body	ASTM A216 GR.WCB		
Seat Ring	ASTM A105/HF		
Disc 2" through 4"	ASTM A276-410	ASTM A216-WCB/HF	ASTM A276-316
Disc 5" and larger	ASTM A216-WCB/13% Chrome		ASTM A216-WCB/316
Disc Nut	ASTM A276-410		ASTM A276-316
Stem	ASTM A276-410		ASTM A276-316
*Bonnet Gasket	Spiral Wound 316 Stainless Steel/Graphite		
Bonnet	ASTM A216-WCB		
Bonnet Studs	ASTM 193-B7		ASTM A193-B7M
Bonnet Nuts	ASTM A194-2H		ASTM A194-2HM
Back Seat Bushing	ASTM A276-410		ASTM A276-316
Packing	Graphite w/Braided Carbon Fiber End Rings		
Gland Bolt Pins	ASTM A36		
Gland Bolts	ASTM 193-B7		ASTM A193-B7M
Gland	ASTM A276-410		ASTM A276-316
Gland Flange	ASTM A216-WCB		
Gland Nuts	ASTM A194-2H		ASTM A194-2HM
Stem Nut	ASTM A439-D2		
Split Ring	ASTM A276-410		
Handwheel Washer	ASTM A36		
Handwheel Nut	ASTM A36		
Handwheel	ASTM A539 Type (65-45-12)		
Spacer Ring	ASTM A276-410		ASTM A276-316

Class 300								
Size	NPS	2	3	4	6	8	10	12
	DN	50	75	100	150	200	250	300
A	In	5.25	6.25	7	8.75	11	12.25	14
	mm	133	159	178	222	279	311	356
B	In	15	16.9	21.7	28	30.7	37.5	41.6
	mm	381	429	551	711	780	953	1049
C	In	10	12	14	17	24	24	27
	mm	254	305	356	432	610	610	686
D	In	6.5	8.25	10	12.5	15	17.5	20.5
	mm	165	210	254	318	381	445	521
RF Wt.	Lbs	68	108	198	392	560	934	1288
	Kg	31	49	90	178	255	425	586

**Note:** Dimensions: Inches/Millimeters - Weights: Pounds/Kilograms. Larger sizes available on request. Dimensions are subject to change without notice.

Styles: CB2, CB3 and CB4/2

Class: 600 - Sizes: 2" to 8"

Pressure Class Range: 150 to 600

**Design and Manufacturing Standards**

Valve Design: ASME B16.34/API 600

Flange Dimensions: ASME B16.5, B16.47 (Series A)

Face to Face Dimensions: ASME B16.10

Tested in Accordance With: API 598

Recommended Spare Parts\*

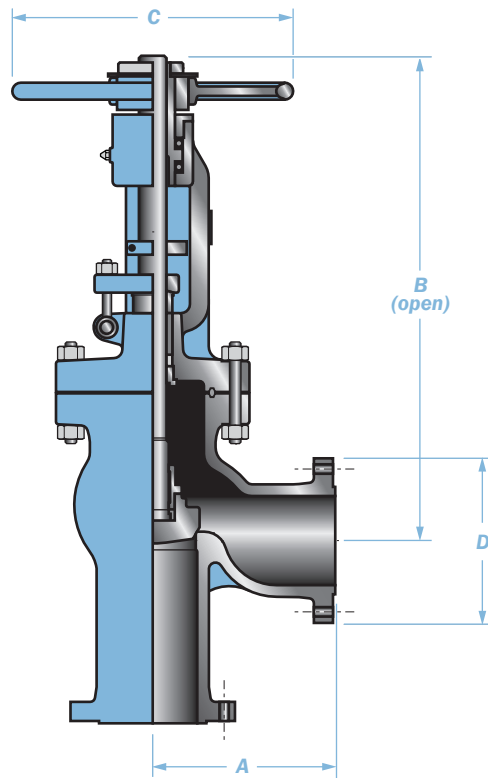

Typical Bill of Materials (See page 89 for available materials)			
Component	CB2	CB3	CB4/2
Body	ASTM A216 GR.WCB		
Seat Ring	ASTM A105/HF		
Disc 2" through 4"	ASTM A276-410	ASTM A216-WCB/HF	ASTM A276-316
Disc 5" and larger	ASTM A216-WCB/13% Chrome		ASTM A216-WCB/316
Disc Nut	ASTM A276-410		ASTM A276-316
Stem	ASTM A276-410		ASTM A276-316
*Bonnet Gasket	Spiral Wound 316 Stainless Steel/Graphite		
Bonnet	ASTM A216-WCB		
Bonnet Studs	ASTM 193-B7		ASTM A193-B7M
Bonnet Nuts	ASTM A194-2H		ASTM A194-2HM
Back Seat Bushing	ASTM A276-410		ASTM A276-316
Packing	Graphite w/Braided Carbon Fiber End Rings		
Gland Bolt Pins	ASTM A36		
Gland Bolts	ASTM 193-B7		ASTM A193-B7M
Gland	ASTM A276-410		ASTM A276-316
Gland Flange	ASTM A216-WCB		
Gland Nuts	ASTM A194-2H		ASTM A194-2HM
Stem Nut	ASTM A439-D2		
Split Ring	ASTM A276-410		
Handwheel Washer	ASTM A36		
Handwheel Nut	ASTM A36		
Handwheel	ASTM A539 Type (65-45-12)		
Spacer Ring	ASTM A276-410		ASTM A276-316

Class 600							
Size	NPS	2	2.5	3	4	6	8
	DN	50	75	100	150	200	250
A	In	5.75	6.5	7.0	8.5	11.0	13.0
	mm	146	165	178	216	279	330
B	In	18.9	20.9	19.8	22.2	28.2	38.5
	mm	480	531	503	564	716	978
C	In	8.8	9.8	11.0	14.0	17.7	24.8
	mm	224	249	279	356	450	630
D	In	6.5	7.5	8.3	9.0	14.0	16.5
	mm	165	191	211	229	356	419
RF Wt.	Lbs	79	110	141	256	640	961
	Kg	36	50	64	116	291	437

**Note:** Dimensions: Inches/Millimeters - Weights: Pounds/Kilograms. Larger sizes available on request. Dimensions are subject to change without notice.

## VIII. HOW TO ORDER ALL CAMERON'S NEWCO PRODUCTS

### Figure Number

The figure number shown below identifies specific valve configuration details of Cameron's NEWCO valves such as valve type, pressure class, end connections, body/bonnet and trim materials, and special features.

Please specify end connections, body materials and trims not listed below.

When placing an order, please refer to the respective product section of the catalog for size availability. A detailed description must be included with any special orders.



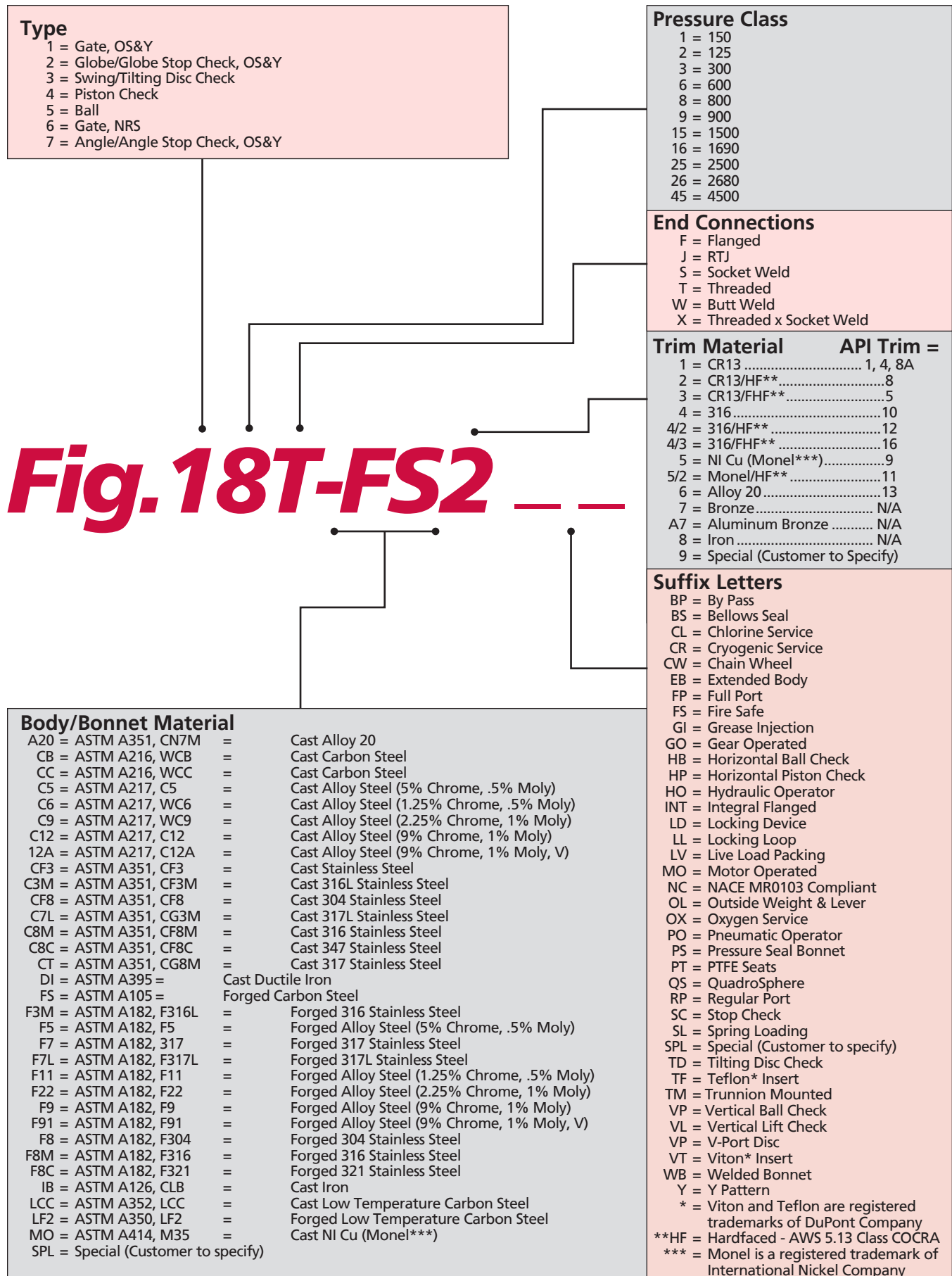

**Type**

- 1 = Gate, OS&Y
- 2 = Globe/Globe Stop Check, OS&Y
- 3 = Swing/Tilting Disc Check
- 4 = Piston Check
- 5 = Ball
- 6 = Gate, NRS
- 7 = Angle/Angle Stop Check, OS&Y

**Pressure Class**

- 1 = 150
- 2 = 125
- 3 = 300
- 6 = 600
- 8 = 800
- 9 = 900
- 15 = 1500
- 16 = 1690
- 25 = 2500
- 26 = 2680
- 45 = 4500

**End Connections**

- F = Flanged
- J = RTJ
- S = Socket Weld
- T = Threaded
- W = Butt Weld
- X = Threaded x Socket Weld

**Trim Material**

**API Trim =**

- 1 = CR13 ..... 1, 4, 8A
- 2 = CR13/HF\*\* ..... 8
- 3 = CR13/FHF\*\* ..... 5
- 4 = 316 ..... 10
- 4/2 = 316/HF\*\* ..... 12
- 4/3 = 316/FHF\*\* ..... 16
- 5 = Ni Cu (Monel\*\*\*) ..... 9
- 5/2 = Monel/HF\*\* ..... 11
- 6 = Alloy 20 ..... 13
- 7 = Bronze ..... N/A
- A7 = Aluminum Bronze ..... N/A
- 8 = Iron ..... N/A
- 9 = Special (Customer to Specify)

**Suffix Letters**

- BP = By Pass
- BS = Bellows Seal
- CL = Chlorine Service
- CR = Cryogenic Service
- CW = Chain Wheel
- EB = Extended Body
- FP = Full Port
- FS = Fire Safe
- GI = Grease Injection
- GO = Gear Operated
- HB = Horizontal Ball Check
- HP = Horizontal Piston Check
- HO = Hydraulic Operator
- INT = Integral Flanged
- LD = Locking Device
- LL = Locking Loop
- LV = Live Load Packing
- MO = Motor Operated
- NC = NACE MR0103 Compliant
- OL = Outside Weight & Lever
- OX = Oxygen Service
- PO = Pneumatic Operator
- PS = Pressure Seal Bonnet
- PT = PTFE Seats
- QS = QuadroSphere
- RP = Regular Port
- SC = Stop Check
- SL = Spring Loading
- SPL = Special (Customer to specify)
- TD = Tilting Disc Check
- TF = Teflon\* Insert
- TM = Trunnion Mounted
- VP = Vertical Ball Check
- VL = Vertical Lift Check
- VP = V-Port Disc
- VT = Viton\* Insert
- WB = Welded Bonnet
- Y = Y Pattern
- \* = Viton and Teflon are registered trademarks of DuPont Company
- \*\*HF = Hardfaced - AWS 5.13 Class COCRA
- \*\*\* = Monel is a registered trademark of International Nickel Company

**Body/Bonnet Material**

- A20 = ASTM A351, CN7M = Cast Alloy 20
- CB = ASTM A216, WCB = Cast Carbon Steel
- CC = ASTM A216, WCC = Cast Carbon Steel
- C5 = ASTM A217, C5 = Cast Alloy Steel (5% Chrome, .5% Moly)
- C6 = ASTM A217, WC6 = Cast Alloy Steel (1.25% Chrome, .5% Moly)
- C9 = ASTM A217, WC9 = Cast Alloy Steel (2.25% Chrome, 1% Moly)
- C12 = ASTM A217, C12 = Cast Alloy Steel (9% Chrome, 1% Moly)
- 12A = ASTM A217, C12A = Cast Alloy Steel (9% Chrome, 1% Moly, V)
- CF3 = ASTM A351, CF3 = Cast Stainless Steel
- C3M = ASTM A351, CF3M = Cast 316L Stainless Steel
- CF8 = ASTM A351, CF8 = Cast 304 Stainless Steel
- C7L = ASTM A351, CG3M = Cast 317L Stainless Steel
- C8M = ASTM A351, CF8M = Cast 316 Stainless Steel
- C8C = ASTM A351, CF8C = Cast 347 Stainless Steel
- CT = ASTM A351, CG8M = Cast 317 Stainless Steel
- DI = ASTM A395 = Cast Ductile Iron
- FS = ASTM A105 = Forged Carbon Steel
- F3M = ASTM A182, F316L = Forged 316 Stainless Steel
- F5 = ASTM A182, F5 = Forged Alloy Steel (5% Chrome, .5% Moly)
- F7 = ASTM A182, 317 = Forged 317 Stainless Steel
- F7L = ASTM A182, F317L = Forged 317L Stainless Steel
- F11 = ASTM A182, F11 = Forged Alloy Steel (1.25% Chrome, .5% Moly)
- F22 = ASTM A182, F22 = Forged Alloy Steel (2.25% Chrome, 1% Moly)
- F9 = ASTM A182, F9 = Forged Alloy Steel (9% Chrome, 1% Moly)
- F91 = ASTM A182, F91 = Forged Alloy Steel (9% Chrome, 1% Moly, V)
- F8 = ASTM A182, F304 = Forged 304 Stainless Steel
- F8M = ASTM A182, F316 = Forged 316 Stainless Steel
- F8C = ASTM A182, F321 = Forged 321 Stainless Steel
- IB = ASTM A126, CLB = Cast Iron
- LCC = ASTM A352, LCC = Cast Low Temperature Carbon Steel
- LF2 = ASTM A350, LF2 = Forged Low Temperature Carbon Steel
- MO = ASTM A414, M35 = Cast Ni Cu (Monel\*\*\*)
- SPL = Special (Customer to specify)

## IX. INDUSTRY STANDARDS TYPICALLY USED IN VALVE MANUFACTURING

### (For Reference Only)

ISO 9001: 2000  
 RWTUV approved NEWCO for design, manufacture, sales, & service of industrial valves under certificate registration number #08-1016  
 ISO 14001: 2004  
 The NEWCO/Yancheng Manufacturing Team has passed the TUV-USA ISO 14001-2004 Certification Audit. All facilities inclusive of two (2) Foundries (Lost Wax and Sand Cast), Ball Valve Factory, Final Processing Center and Warehouses 15 & 16.

### American Petroleum Institute (API)

API RP 574 (1998) - Inspection practices for piping system components  
 API 589 (1998) - Fire test for evaluation of valve stem packing  
 API RP 591 (2003) - Process valve qualification procedure  
 API 594 (2004) - Check valves-flanged, lug, wafer & buttwelding  
 API 597 (1981) - Steel venturi gate valves, flanged, buttwelding ends  
 API 598 (2004) - Valve inspection & testing  
 API 599 (2002) - Metal plug valves - flanged, welding ends  
 API 601 (1988) - Metallic gaskets for raised-face pipe flanges & flanged connections (double-jacketed corrugated & spiral wound)  
 API 600 (2001) - Bolted bonnet steel gate valves for petroleum & natural gas industries "ISO adoption from ISO 10434"  
 API 602 (2005) - Steel gate, globe, & check valves for sizes DN100 and smaller for the petroleum & natural gas industries  
 API 603 (2001) - Corrosion-resistant, bolted bonnet gate valves-flanged & buttweld ends  
 API 604 (1981) - Ductile iron gate valves, flanged ends  
 API 605 (1988) - Large-diameter carbon steel flanges (nominal pipe sizes 26" through 60", classes 75, 150, 300, 400, 600, & 900 (replaced by ANSI/ASME B16.47)  
 API 606 (1989) - Compact steel gate valves, extended body (included in API 602) fire test for soft-seated quarter-turn valves "ISO adoption from ISO 10497-5 2004"  
 API 607 (2005) - Fire test for soft-seated quarter-turn valves "ISO adoption from ISO 10497-5 2004"  
 API 608 (2002) - Metal ball valves, flanged, threaded, & welding ends  
 API 609 (2004) - Butterfly valves-double flanged, lug- & wafer-type  
 API RP 941 (2004) - Steel for hydrogen service at elevated temperatures & pressures in petroleum refineries & petrochemical plants  
 API RP 520 (2000), Part 1 - Sizing, selection & installation of pressure relieving devices in refineries  
 API RP 520 (2003), Part 2 - Sizing, selection & installation of pressure relieving devices in refineries devices in refineries  
 API Spec 6A (2005) - Specification for wellhead & christmas tree equipment  
 API Spec 6D (2005) - Specifications for pipeline valves  
 API Spec 14D (1994) - Specifications for wellhead surface safety valves & underwater safety valves for offshore service  
 API 5B (2004) - Threading, gauging thread inspection of coring, tubing, & line pipe threads  
 API 6AM (2003) - Material toughness  
 API 6FA (1999) - Fire test for valves  
 API 6FC (1999) - Fire test for valves with backseats  
 API 6FD (1995) - Specification for fire test for check valves  
 API Q1 (2003) - Specification for quality programs for the petroleum, petrochemical, & natural gas

### American Society of Mechanical Engineers (ASME)

ASME Code (1997 addenda) - Boiler & pressure vessel code  
 ASME A13.1 (1996) - Scheme for the identification of piping systems  
 ASME B1.1 (2003) - Unified inch screw threads, UN, & UNR thread form  
 ASME B1.5 (1997) - ACME screw threads  
 ASME B1.7M (1984) - Nomenclature, definitions, & letter symbols for screw threads  
 ASME B1.8 (1988) - Stub ACME screw threads  
 ASME B1.12 (1987) - Class 5 interference - fit thread  
 ASME B1.20.1 (1983) - Pipe threads, general purpose, inch  
 ASME B1.20.3 (1976) - Dry-seal pipe threads, inch  
 ANSI/ASME B16.1 (1998) - Cast iron pipe flanges & flanged fittings  
 ANSI/ASME B16.5 (2003) - Pipe flanges & flanged fittings: NPS 1/2" through 24"  
 ASME B16.9 (2003) - Factory made wrought steel buttwelding fittings  
 ANSI/ASME B16.10 (2002) - Face-to-face & end-to-end dimensions of valves  
 ASME B16.11 (2001) - Forged fittings, socket welding & threaded  
 ASME B16.20 (1998) - Metallic gaskets for pipe flanges: ring joint spiral wound & jacketed  
 ASME B16.21 (2005) - Non-metallic flat gaskets for pipe flanges  
 ASME B16.25 (2003) - Buttwelding ends  
 ANSI/ASME B16.33 (2002) - Manually operated metallic gas valves for use in gas piping systems up to 125 PSI (sizes NPS 1/2" through 2")  
 ANSI/ASME B31.1 (2004) - Power piping  
 ANSI/ASME B31.3 (2004) - Process piping  
 ANSI/ASME B16.34 (2004) - Valves flanged, threaded & welding end  
 ANSI/ASME B16.36 (1996) - Orifice flanges  
 ANSI/ASME B16.38 (1985) - Large metallic valves for gas distribution (manually operated, NPS 2-1/2" through 12", 125 PSIG maximum)  
 ANSI/ASME B16.42 (1998) - Ductile iron pipe flanges & flanged fittings: classes 150 & 300  
 ANSI/ASME B16.47 (1996) - Large diameter steel flanges  
 ANSI B17.1 (1967, R' 89) - Keys & keyseats  
 ANSI B18.2.2 (1987) - Square & hex nuts  
 ASME B31.4 (2002) - Pipeline transportation systems for liquid hydrocarbons & other ammonia & alcohols  
 ANSI/ASME B31.8 (2003) - Gas transmission & distribution piping systems  
 ANSI/ASME B36.10 (2004) - Welded & seamless wrought steel pipe  
 ANSI/ASME B36.19 (2004) - Stainless steel pipe  
 ANSI FCI-2 (1991) - Control valve seat leakage

### American Society Non-destructive Test (ASNT)

ASNT-TC-1A (1996) - Recommended practice no. SNT-TC-1A 1996

### American Society for Testing and Materials (ASTM)

### British Standards Institute (BS)

BS 1414 (1975, R' 91) - Gate, wedge & double disk valves: steel  
 BS 1868 (1975, R' 91) - Check valves: steel  
 BS 1873 (1975, R' 91) - Globe & check valves: steel  
 BS 2080 (1989) obsolete - Flanged & buttweld end steel valves  
 BS 5146 - (withdrawn) Replaced by BS 6755 p.1 steel valves testing (1986) & BS 6755 p.2 (1984)  
 BS 5152 (1974, R' 91) - Globe & check: cast iron  
 BS 5153 (1974, R' 91) - Check: cast iron  
 BS 5159 (1974, R' 91) - Ball: cast iron & carbon steel  
 BS 5160 (1974, R' 91) - Globe & check: steel  
 BS 5163 (1986, R' 91) - Gate, wedge & double disk: cast iron  
 BS 5351 (1986, R' 91) - Ball: steel  
 BS 5352 (1986, R' 91) - Globe & check: steel  
 BS 5418 - (withdrawn) Replaced by BS EN 19 (1992) marking: general purpose industrial  
 BS 5840 (1980, R' 91) - Valve mating details for actuator operation  
 BS 6364 (1984, R' 91) - Cryogenic  
 BS 6683 (1985, R' 91) - Guide: installation & use of valves  
 BS 6755: Part 1 (1986, R' 91) - Specification for production pressure testing requirements  
 BS 6755: Part 2 (1987) - Specification for fire type-testing requirements  
 BS EN 19 (1992) - Marking of general purpose industrial valves

### Canadian Standards Association

B51-97 - Boiler, pressure vessel, & pressure piping code  
 Z245.15-96 - Steel valves  
 CAN3-z299.4-85 (reaffirmed 1997) - Quality assurance program - Category 4  
 CAN3-z299.3-85 (reaffirmed 1997) - Quality assurance program - Category 3

### International Organization for Standardization

ISO 5211/1 (2001) - Industrial valves- part-turn actuator attachments  
 ISO 5211/2 (2001) - Part-turn valve actuator attachment-flange & coupling performance characteristics  
 ISO 5211/3 (2001) - Part-turn valve actuator attachment-dimensions of driving components  
 ISO 5752 (1982) - Metal valves for use in flanged pipe systems face-to-face & center-to-face dimensions  
 ISO 9000 (2005) - Quality management systems and fundamentals & vocabulary  
 ISO 10012-1 (1992) - Quality assurance requirements for measuring equipment

### Manufacturers Standardization Society

SP-6 (2001) - Standard finishes for contact faces of pipe flanges & connecting-end flanges of valves & fittings  
 SP-9 (r2005) - Spot facing for bronze, iron & steel flanges  
 SP-25 (1998) - Standard marking system for valves, fittings, flanges & unions  
 SP-42 (2004) - Class 150 corrosion resistant gate, globe, angle, & check valves with flanged & buttweld ends  
 SP-44 (2001) - Steel pipeline flanges  
 SP-45 (2003) - Bypass & drain connections  
 SP-51 (2003) - Class 150/w corrosion resistant cast flanges & flanged fittings  
 SP-53 (2002) - Quality standard for steel castings & forgings for valves, flanges, & fittings & other piping components: magnetic particle exam method  
 SP-54 (2002) - Quality standard for steel castings for valves, flanges, & fittings and other piping components: radiographic examination method  
 SP-55 (2001) - Quality standard for steel castings for valves, flanges other piping components-visual method for evaluation of surface irregularities  
 SP-60 (2004) - Connecting flange joint between tapping sleeves & tapping valves  
 SP-61 (2003) - Pressure testing of steel valves  
 SP-65 (2004) - High pressure chemical industry flanges & threaded stubs for use with lens gaskets  
 SP-67 (2000A) - Butterfly valves  
 SP-69 (2003) - ANSI/MSS edition pipe hangers & supports, selection & application  
 SP-70 (1998) - Cast iron gate valves, flanged & threaded ends  
 SP-71 (1997) - Gray iron swing check valves, flanged & threaded ends  
 SP-72 (1999) - Ball valves with flanged or butt-welding ends for general service  
 SP-79 (2004) - Socket-welding reducer inserts  
 SP-81 (2001) - Stainless steel, bonnetless, flanged knife gate valves  
 SP-82 (1992) - Valve pressure testing methods  
 SP-84 (1990) - Valves - socket welding & threaded ends  
 SP-85 (2002) - Cast iron globe & angle valves, flanged & threaded ends  
 SP-86 (2002) - Guidelines for metric data in standards for valves, flanges, fittings & actuators  
 SP-88 (r2001) - Diaphragm valves  
 SP-91 (1992) - Guidelines for manual operation of valves  
 SP-92 (1999) - MSS valve user guide  
 SP-93 (r2004) - Quality standard for steel castings & forgings for valves, flanges & fittings & other piping components- liquid penetrant exam method  
 SP-94 (r2004) - Quality standard for ferritic & martensitic steel castings for valves, flanges, & fittings and other piping components - ultrasonic exam method  
 SP-96 (r2005) - Guidelines on terminology for valves & fittings  
 SP-98 (2001) - Protective coatings for the interior of valves, hydrants, & fittings  
 SP-99 (r2005) - Instrument valves  
 SP-101 (r2001) - Part-turn valve actuator attachment-flange and driving component dimensions & performance characteristics  
 SP-102 (r2001) - Multi-turn valve actuator attachment: flange and driving component dimensions & performance characteristics  
 SP-110 (1996) - Ball valves threaded, socket-welding, solder joint, grooved, & flared ends  
 SP-117 (2002) - Bellows seals for globe & gate valves  
 SP-118 (2002) - Compact steel globe and check valves-flanged, flangeless, threaded & welding ends (chemical & petroleum refinery service)  
 SP-120 (2002) - Flexible graphite packing system for rising stem steel valves (design requirements)  
 SP-121 (R2002) - Qualification testing methods for stem packing for rising stem steel valves

### National Association of Corrosion Engineers (NACE)

MR0175 (2005) - Sulfide stress cracking resistant metallic materials for oil field equipment  
 MR0103 (2005) - Materials resistant to sulfide stress cracking in corrosive petroleum refining environments

**NOTES:**



## VALVES & MEASUREMENT

13127 Trinity Dr.

Stafford, Tx 77477

Toll Free 800.231.3505

Tel 281.302.4900

Fax 281.302.4801

Learn more about Cameron's NEWCO valves at:

[www.c-a-m.com/newco](http://www.c-a-m.com/newco)

[newco@c-a-m.com](mailto:newco@c-a-m.com)



### **HSE Policy Statement**

At Cameron, we are committed ethically, financially and personally to a working environment where no one gets hurt, nothing gets harmed.