



# PICTORIAL INDEX



**FIG. 41 Page 8**  
**SWIVEL RING HANGER**  
MSS SP-58 and SP-69 TYPE 10



**FIG. 41 PVC Page 9**  
**SWIVEL RING HANGER**  
**PVC**  
MSS SP-58 and SP-69 TYPE 10



**FIG. 43 Page 10**  
**SWIVEL RING HANGER**  
**Epoxy Coated**  
MSS SP-58 and SP-69 TYPE 10



**FIG. E31 Page 11**  
**BAND HANGER**  
MSS SP-58 and SP-69 TYPE 10



**FIG. 22Z Page 12**  
**CLEVIS HANGER**  
**Light Duty**  
MSS SP-58 and SP-69 TYPE 1



**Fig. 24Z Page 13**  
**CLEVIS HANGER**  
**Standard Duty**  
MSS SP-58 and SP-69 TYPE 1



**FIG. 24L Page 14**  
**CLEVIS HANGER**  
**Extended**  
MSS SP-58 and SP-69 TYPE 1



**FIG. 27AC Page 15**  
**CLEVIS HANGER**  
**For AWWA - AC Transite Pipe**  
MSS SP-58 and SP-69 TYPE 1



**FIG. 52 Page 16**  
**CLEVIS HANGER**  
**Copper-Gard**  
MSS SP-58 and SP-69 TYPE 1



**FIG. 25 Page 17**  
**MJ HANGER**



**FIG. 34 Page 18-19**  
**VIBRATION HANGER**  
**NHD Series**



**FIG. 36 Pages 20-27**  
**VIBRATION HANGER**  
**SH Series**



**FIG. 178 Page 28**  
**SPRING CUSHION HANGER**



**FIG. 32S Page 29**  
**PIPE STAY**  
**Standard**



**FIG. 32E Page 30**  
**PIPE STAY**  
**Extended**



**FIG. 32D Page 31**  
**PIPE STAY**  
**Double**



**FIG. 44 Page 32**  
**ONE-HOLE PIPE STRAP**



**FIG. 45 Page 33**  
**TWO-HOLE PIPE STRAP**  
MSS SP-58 and SP-69 TYPE 26



**FIG. 45C Page 34**  
**TWO-HOLE PIPE STRAP**  
**Copper-Gard**  
MSS SP-58 and SP-69 TYPE 26



**FIG. 45SS Page 35**  
**TWO-HOLE PIPE STRAP**  
**Stainless Steel**  
MSS SP-58 and SP-69 TYPE 26



**FIG. 46 Page 36**  
**HOLD DOWN CLAMP**  
MSS SP-58 and SP-69 TYPE 26



**FIG. 129 Page 37**  
**BELL (VAN) HANGER**  
Copper-Gard



**FIG. 31 Page 38**  
**2-BOLT PIPE CLAMP**  
MSS SP-58 and SP-69 TYPE 4



**FIG. 31H Page 39**  
**HEAVY 2-BOLT PIPE CLAMP**  
MSS SP-58 and SP-69 TYPE 4



**Fig. 33M Page 40**  
**3-BOLT PIPE CLAMP Med. Duty**  
MSS SP-58 and SP-69 TYPE 3



**FIG. 33A Page 41**  
**ALLOY 3-BOLT PIPE CLAMP**  
MSS SP-58 and SP-69 TYPE 3



**FIG. 33H Page 42**  
**HEAVY 3-BOLT PIPE CLAMP**  
MSS SP-58 and SP-69 TYPE 3



**FIG. 35 Page 43**  
**UNDERGROUND BELL CLAMP**



**FIG. 38R Page 44**  
**HINGED SPLIT RING HANGER**  
MSS SP-58 and SP-69 TYPE 12



**FIG. 38R SS Page 45**  
**SPLIT RING HANGER**  
Stainless Steel  
MSS SP-58 and SP-69 TYPE 12



**FIG. 38C Page 46**  
**HINGED SPLIT RING HANGER**  
Copper-Gard  
MSS SP-58 and SP-69 TYPE 12



**Bismat® 5000 Page 47**  
**RUBBER LINED CLAMP**  
MSS SP-58 and SP-69 TYPE 12



**Fig. 40 Page 48**  
**SPLIT RING HANGER - EPDM**  
MSS SP-58 and SP-69 TYPE 12



**FIG. 47, 48, 49 Page 49**  
**MANHOLE DROP PIPE CLAMP**



**StarQuick® Page 50-55**  
**SELF-LOCKING PIPE CLAMP**



UL LISTED  
\*  
C US

\* **FIG. 82Z Page 56**  
**FIG. 82SS Page 57**  
**STD. RISER CLAMP**



**FIG. 82H Page 58**  
**HEAVY DUTY RISER CLAMP**  
MSS SP-58 and SP-69 TYPE 8



**FIG. 85 Page 59**  
**RISER CLAMP Copper-Gard**  
MSS SP-58 and SP-69 TYPE 8



**FIG. 87 Page 60**  
**OFFSET PIPE CLAMP**



**FIG. 88 Page 61**  
**EXTENDED PIPE CLAMP**



# PICTORIAL INDEX



**FIG. 159 Page 62**  
**ADJ. ROD BEAM CLAMP**  
MSS SP-58 and SP-69 TYPE 27



**FIG. 201 Page 63**  
**STAMPED "C" CLAMP**  
MSS SP-58 and SP-69 TYPE 23



**FIG. 301 Page 64**  
**MALLEABLE "C" CLAMP**  
MSS SP-58 and SP-69 TYPE 23



**FIG. 404 Page 65**  
**PURLIN CLAMP**  
MSS SP-58 and SP-69 TYPE 23



**FIG. 405 Page 66**  
**INSULATOR SUPPORT**



**FIG. 406 Page 67**  
**SMALL MOUTH TOP BEAM CLAMP**  
MSS SP-58 and SP-69 TYPE 19

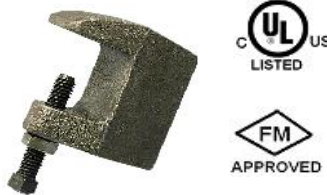

**FIG. 407 Page 68**  
**WIDE MOUTH TOP BEAM CLAMP**  
MSS SP-58 and SP-69 TYPE 19



**Fig. 410 Page 69**  
**MALLEABLE BEAM CLAMP**  
MSS SP-58 and SP-69 TYPE 30



**FIG. 416 Page 70**  
**RETAINING STRAP**



**FIG. 425 Page 71**  
**BEAM CLAMP**  
MSS SP-58 and SP-69 TYPE 21



**FIG. 426 Page 72**  
**STEEL BEAM CLAMP**



**Fig. 450 Page 73**  
**HEAVY BEAM CLAMP**  
MSS SP-58 and SP-69  
(Type 28 without links, Type 29 with links)



**Fig. 28R Page 74**  
**CEILING FLANGE**



**FIG. 55 & 55L Page 75**  
**STRUCTURAL WELDING LUG**  
MSS SP-58 and SP-69 TYPE 57



**FIG. 66 Page 76**  
**WELDED BEAM ATTACHMENT**  
MSS SP-58 and SP-69 TYPE 22



**FIG. 67 Page 76**  
**WELDED BEAM ATTACHMENT**  
MSS SP-58 and SP-69 TYPE 22



**FIG. 80 Page 77**  
**STEEL WASHER PLATE**



**FIG. 81 Page 78**  
**CONCRETE INSERT**  
MSS SP-58 and SP-69 TYPE 18



**FIG. 115 Page 79**  
**45° BRACING ATTACHMENT**



**FIG. 120 Page 80**  
**SIDE BEAM BRACKET**  
MSS SP-58 and SP-69 TYPE 34



# PICTORIAL INDEX



**FIG. 166 Page 81**  
**CONCRETE CEILING PLATE**



**FIG. 167 Page 82**  
**CONCRETE CEILING PLATE**



**FIG. 14 Page 83**  
**"U" BOLT**  
**STD. DUTY - BARE**  
MSS SP-58 and SP-69 TYPE 24



**FIG. 14Z Page 84**  
**"U" BOLT**  
**STD. DUTY - ZINC**  
MSS SP-58 and SP-69 TYPE 24



**FIG. 15Z Page 85**  
**HEX. NUTS**



**FIG. 17W Page 86**  
**20° SWIVEL ROD EXTENSION**



**FIG. 53 Page 87**  
**HANGER ROD**



**FIG. 54 Page 88**  
**ALL THREADED ROD**



**FIG. 57 & 58 Page 89**  
**THREADED HANGER ROD**



**FIG. 59 Page 90**  
**WOOD DRIVE SCREW**



**FIG. 60WZ Page 91**  
**COACH SCREW ROD**



**Fig. 62 Page 92**  
**ROD COUPLING**



**FIG. 63 Page 93**  
**FORGED STEEL CLEVIS**  
MSS SP-58 and SP-69 TYPE 14



**FIG. 64 Page 94**  
**WELDLESS EYE NUT**  
MSS SP-58 and SP-69 TYPE 17



**FIG. 65 Page 95**  
**EYE SOCKET**  
MSS SP-58 and SP-69 TYPE 16



**Fig. 68 Page 96**  
**TURNBUCKLE**  
MSS SP-58 and SP-69 TYPE 13



**Fig. 114 Page 97**  
**TURNBUCKLE ADJUSTER**  
MSS SP-58 and SP-69 TYPE 15



**Fig. 411 Page 98**  
**EXTENSION PIECE**



**FIG. 69 Page 99**  
**PROTECTION SHIELD**



**FIG. 69H Page 100**  
**PROTECTION SHIELD - HEAVY**  
MSS SP-58 and SP-69 TYPE 40

# PICTORIAL INDEX



**FIG. 70 to 77 Pages 101-108**  
**PROTECTION SADDLES**  
MSS SP-58 and SP-69 TYPE 39



**FIG. 255 Page 109**  
**PIPE ALIGNMENT GUIDE**



**FIG. 256 Page 110**  
**PIPE ALIGNMENT GUIDE**



**FIG. 520 Page 111**  
**PIPE SADDLE SUPPORT**



**FIG. 521 Page 112**  
**ADJ. PIPE SADDLE SUPPORT**  
c/w COUPLING



**FIG. 192 Page 113**  
**ADJUSTABLE PIPE SUPPORT**



**FIG. 525 Page 114**  
**ADJ. PIPE SADDLE SUPPORT**  
c/w U-BOLT  
MSS SP-58 and SP-69 TYPE 36, 37



**FIG. 526 Page 115**  
**ADJ. PIPE SADDLE SUPPORT**  
MSS SP-58 and SP-69 TYPE 38



**FIG. 527 Page 116**  
**ADJ. PIPE SADDLE SUPPORT**  
c/w U-BOLT  
MSS SP-58 and SP-69 TYPE 37, 38



**FIG. 528KT Page 117**  
**ADJ. PIPE SADDLE SUPPORT KIT**  
MSS SP-58 and SP-69 TYPE 36, 38



**FIG. 529KT Page 118**  
**ADJ. PIPE SADDLE SUPPORT KIT**  
c/w U-BOLT  
MSS SP-58 and SP-69 TYPE 37, 38



**FIG. 501 Page 119**  
**STUD PLATE**



**FIG. 92 Page 120**  
**PIPE ROLL**



**FIG. 92S Page 121**  
**PIPE ROLL - SHORT**



**FIG. 93 Page 122**  
**ADJUSTABLE ROLLER HANGER**  
MSS SP-58 and SP-69 TYPE 43



**FIG. 94 Page 123**  
**ROLLER CHAIR**  
MSS SP-58 and SP-69 TYPE 44

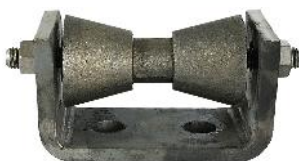

**Fig. 94S Page 124**  
**SHORT ROLLER CHAIR**  
MSS SP-58 and SP-69 TYPE 44



**FIG. 95 Page 125**  
**ADJ. 2-ROD ROLLER HANGER**  
MSS SP-58 and SP-69 TYPE 41



**FIG. 95S Page 126**  
**ADJ. 2-ROD ROLLER SUPPORT**  
MSS SP-58 and SP-69 TYPE 41



**FIG. 279S Page 127**  
**PIPE ROLL STAND**  
MSS SP-58 and SP-69 TYPE 44

# PICTORIAL INDEX



**FIG. 170 Page 128**  
**CHANNEL ASSEMBLY**



**FIG. 801 Page 129**  
**MEDIUM WELDED BRACKET**  
MSS SP-58 and SP-69 TYPE 32



**FIG. 802 Page 130**  
**HEAVY WELDED BRACKET**  
MSS SP-58 and SP-69 TYPE 33



**Fig. AC100/200 Page 131**  
**AIR CONDITIONER BRACKET**



# #41 Swivel Ring Hanger

Finish: Pre-Galvanized with Zinc Plated insert nut

Material: Carbon Steel  
Stainless Steel (#41 304SS) and (#41 316SS): 1/2" - 4" Only

Approvals: ULC, UL and FM and complies with  
MSS SP-58 & SP-69 (Type 10)  
(Note: approvals do not apply to Stainless)

Recommended: for the suspension of non-insulated stationary  
pipe lines allowing for vertical adjustment



IRON PIPE SIZE	SPECIFICATION DATA					REC. MAX LOAD (LBS)	APP'X WT. PER 100 (LBS)	PC'S PER PKG.
	A	B	C	D	E			
1/2	3/8	2 15/16	1 7/8	3 3/8	1 7/16	400	9	100
3/4	3/8	2 7/8	1 7/8	3 3/8	1 11/32	400	9	100
1	3/8	2 7/8	1 7/8	3 1/2	1 7/32	400	9	100
1 1/4	3/8	3 1/16	1 15/16	3 7/8	1 1/8	400	10	100
1 1/2	3/8	3 3/16	2 1/8	4 1/8	1 3/16	400	11	100
2	3/8	3 7/16	2 7/16	4 5/8	1 1/4	400	12	100
2 1/2	3/8	3 13/16	2 3/4	5 1/4	1 3/8	600	28	50
3	3/8	4	3	5 3/4	1 1/4	600	30	50
4	3/8	4 3/4	3 3/4	7	1 1/2	1000	37	25
5	1/2	6	4 3/4	8 3/4	1 15/16	1000	83	20
6	1/2	6 9/16	5 1/4	9 7/8	1 15/16	1250	95	15
8	1/2	7 13/16	6 5/8	12 1/8	2 5/16	1250	118	10

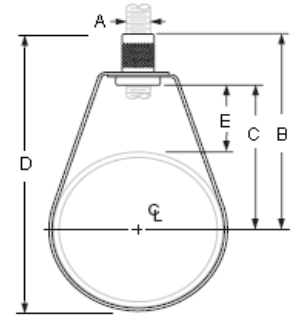

QWI 4.3.1 Issue Date Feb/15 Rev.5

*Note: when referencing a printed copy of this specification page please insure it is the latest version as found on our website at [www.taylorassociates.com](http://www.taylorassociates.com)*

**SWIVEL RING HANGER - PVC Coated #41PVC**

- 1 1/2" through 6"
- Carbon Steel
- Black PVC Coating c/w Zinc Insert Nut
- Complies with MSS SP-58 & SP-69 (Type 10).
- Recommended for the suspension of stationary glass pipe lines
- Specify pipe, size, figure number and name.

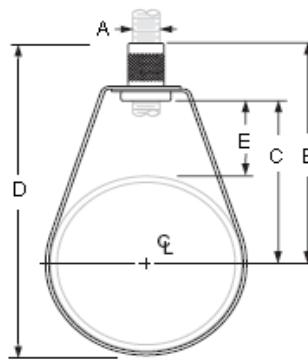

GLASS PIPE SIZE	SPECIFICATION DATA					REC. MAX. LOAD (LBS.)	APP'X WT. PER 100 (LBS)	PC'S PER PKG.
	A	B	C	D	E			
1 1/2	3/8	3 3/16	2 1/8	4 1/8	1 3/16	400	11	100
2	3/8	3 7/16	2 7/16	4 5/8	1 1/4	400	13	100
3	3/8	4	3	5 3/4	1 1/4	600	31	50
4	3/8	4 3/4	3 3/4	7	1 1/2	600	38	25
6	1/2	6 9/16	5 1/4	9 7/8	1 15/16	1250	96	15



QW1 4.3.1 Issue Date Mar/12 Rev.0

*Note: when referencing a printed copy of this specification page please insure it is the latest version as found on our website at [www.taylorassociates.com](http://www.taylorassociates.com)*

# #43 Swivel Ring Hanger

**Finish:** Black Powder Epoxy Coating c/w Zinc Insert Nut

**Material:** Carbon Steel

**Approvals:** Complies with MSS SP-58 & SP-69 (Type 10).

**Recommended:** Recommended for the suspension of stationary non-insulated copper or iron pipe lines allowing for vertical adjustment.

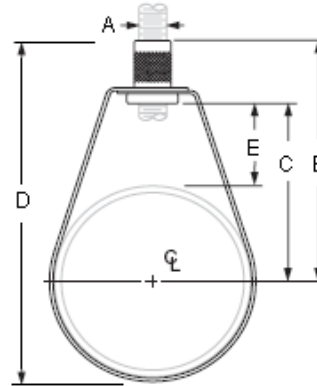

\* 1" & 1 1/4" Copper Tube  
Size Profile

COPPER TUBE SIZE	ALSO ACCOMMODATES IPS SIZE	SPECIFICATION DATA					REC. MAX. LOAD (LBS.)	APP'X WT. PER 100 (LBS)	PC'S PER PKG.
		A	B	C	D	E			
1/2 - 3/4	1/2	3/8	2 13/16	1 15/16	3 1/4	1 5/16	400	9	100
* 1	3/4 - 1	3/8	2 11/16	1 13/16	3 3/8	1 1/4	400	9	100
* 1 1/4	3/4 - 1	3/8	2 1/2	1 5/8	3 3/8	15/16	400	9	100
1 1/2	1 1/4	3/8	2 15/16	2 1/16	3 3/4	1 3/16	400	10	100
2	2	3/8	3 7/16	2 9/16	4 9/16	1 3/8	400	12	100
2 1/2	2 1/2	3/8	3 11/16	2 13/16	5 1/16	1 3/8	650	28	50
3	3	3/8	4	3 1/8	5 5/8	1 3/8	650	30	50
4	4	3/8	4 5/8	3 3/4	6 7/8	1 1/2	650	37	25
5	5	1/2	5 3/4	4 3/4	8 1/2	1 15/16	1000	83	20
6	6	1/2	6 5/8	5 9/16	9 7/8	2 1/4	1250	95	15
8	8	1/2	7 3/4	6 11/16	12 1/16	2 3/8	1250	118	10



QWI 4.3.1 Issue Date Aug/18 Rev.9

Note: when referencing a printed copy of this specification page, please insure it is the latest version as found on our website at [www.taylorassociates.com](http://www.taylorassociates.com)

For more information, please contact Customer Service at 1-800-263-8652



# #E31 Band Hanger

Finish: Bare Metal, Zinc Plated (#E31Z)

Material: Carbon Steel  
Stainless Steel (#E31 304SS) and (#E31 316SS)

Approvals: Complies with MSS SP-58 & SP-69 (Type 10)

Recommended: for the suspension of non-insulated stationary pipe lines allowing for vertical adjustment. Secure with hex nuts (not supplied) tightened securely top and bottom.

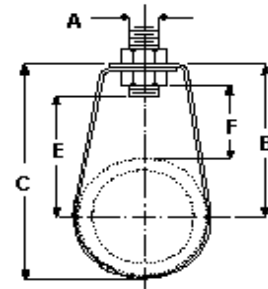

IRON PIPE SIZE	SPECIFICATION DATA					REC. MAX LOAD (LBS)	MATERIAL	APP'X WT. PER 100 (LBS)
	A	B	C	E	F			
2 1/2	1/2	3 3/8	4 13/16	2 1/4	1 5/16	970	14Ga x 1	28
3	1/2	3 3/4	5 9/16	2 5/8	1 3/8	970	13Ga x 1	38
4	1/2	4 5/8	6 15/16	3 7/16	1 11/16	1250	11Ga x 1	60
5	1/2	5 1/16	7 7/8	3 15/16	1 5/8	1250	11Ga x 1	70
6	3/4	6 3/8	9 3/4	4 3/4	2 3/16	1600	11Ga x 1 1/2	134
8	3/4	8 1/16	12 7/16	6 7/16	2 7/8	1800	11Ga x 1 1/2	164



QWI 4.3.1 Issue Date Feb/15 Rev.0

*Note: when referencing a printed copy of this specification page please insure it is the latest version as found on our website at [www.taylorassociates.com](http://www.taylorassociates.com)*

### CLEVIS HANGER ZINC - Light Duty #22Z

- 1/2" through 4"
- Carbon Steel
- Electro-plated Zinc
- Complies with MSS SP-58 and SP-69 (Type 1).
- Recommended for the suspension of non-insulated stationary pipe lines allowing for vertical adjustment.
- Specify pipe size, figure number and name.
- Also available in Stainless Steel 316 (SS6)

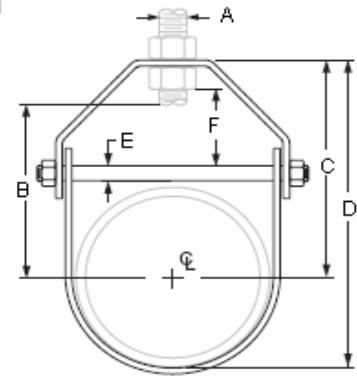

'B'  
Rod Take-Out  
Pipe center to bottom of hanger rod.  
'C'  
Pipe center to top of hanger.  
'D'  
Bottom of pipe to  
top of hanger

IRON PIPE SIZE	SPECIFICATION DATA								REC. MAX LOAD (LBS)	APP'X WT. PER 100 (LBS)	PC'S PER PKG.
	A	B	C	D	E	F	UPPER	LOWER			
1/2	3/8	1 1/8	1 3/4	2 1/8	1/4	1/2	18 ga x 7/8	18 ga x 7/8	250	12	100
3/4	3/8	1 9/16	1 13/16	2 5/16	1/4	1/2	18 ga x 7/8	18 ga x 7/8	250	12	100
1	3/8	1 3/4	2 1/8	2 3/4	1/4	3/4	18 ga x 7/8	18 ga x 7/8	250	12	100
1 1/4	3/8	2 1/32	2 1/2	3 1/4	1/4	15/16	18 ga x 7/8	18 ga x 7/8	250	18	100
1 1/2	3/8	2 1/4	2 13/16	3 13/16	1/4	1 1/8	14 ga x 7/8	16 ga x 7/8	250	24	100
2	3/8	2 11/16	3 5/16	4 1/2	1/4	1 1/4	14 ga x 7/8	16 ga x 7/8	250	26	100
2 1/2	1/2	3 7/16	4 1/2	5 5/16	1/4	2 1/16	12 ga x 1 3/16	14 ga x 1 3/16	350	58	50
3	1/2	3 7/8	4 13/16	6 9/16	5/16	1 7/8	12 ga x 1 3/16	14 ga x 1 3/16	350	66	25
3 1/2	1/2	4 5/8	5 15/16	7 7/8	5/16	2 5/8	11 ga x 1 3/16	14 ga x 1 3/16	350	82	25
4	1/2	4 7/8	6 1/16	8 5/16	3/8	2 3/8	11 ga x 1 3/16	14 ga x 1 3/16	400	94	25



QWI 4.3.1 Issue Date Mar/14 Rev.11

*Note: when referencing a printed copy of this specification page please insure it is the latest version as found on our website at [www.taylorassociates.com](http://www.taylorassociates.com)*

# #24 Clevis Hanger

**Finishes:** Zinc Plated, Bare Metal, Hot Dipped Galvanized, Epoxy

**Materials:** Carbon Steel, Stainless Steel 304SS & 316SS

**Approvals:** Complies with MSS SP-58 and SP-69 (Type 1).  
cUL Approved (2 1/2" through 8" - Mild Steel & S/S)  
FM Approved (3/4" through 8" - Mild Steel Only)

**Recommended:** Recommended for the suspension of non-insulated, stationary pipe lines allowing for vertical adjustment.

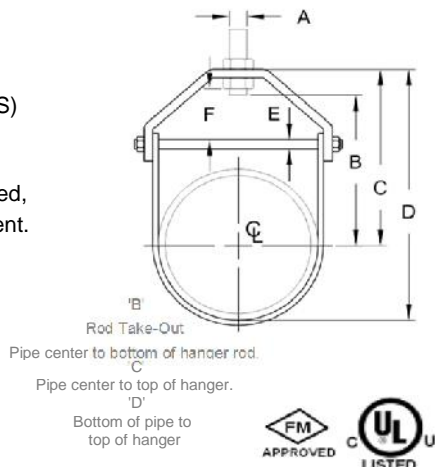

IRON PIPE SIZE	SPECIFICATION DATA							REC. MAX LOAD (LBS)	APP'X WT.PER 100 PCS.	PC'S PER PKG.	
	A	B	C	D	E	F	UPPER				LOWER
1/2	3/8	1 1/8	1 11/16	2 1/16	1/4	7/16	13 ga x 7/8	13 ga x 7/8	730	18	100
3/4	3/8	1 1/8	1 11/16	2 9/16	1/4	7/16	13 ga x 7/8	13 ga x 7/8	730	18	100
1	3/8	1 5/16	2 1/16	2 11/16	1/4	5/8	13 ga x 7/8	13 ga x 7/8	730	22	100
1 1/4	3/8	1 5/8	2 1/2	3 3/16	1/4	7/8	13 ga x 7/8	13 ga x 7/8	730	26	100
1 1/2	3/8	1 7/8	2 7/8	3 11/16	1/4	1 1/16	12 ga x 7/8	12 ga x 7/8	730	34	100
2	3/8	2 1/4	3 5/16	4 7/16	1/4	1 1/4	12 ga x 7/8	12 ga x 7/8	730	38	50
2 1/2	1/2	2 7/8	4 1/2	5 7/8	5/16	1 15/16	9 ga x 1 3/16	10 ga x 1 3/16	1350	86	50
3	1/2	3 5/16	4 3/4	6 1/2	5/16	1 3/4	9 ga x 1 3/16	10 ga x 1 3/16	1350	96	25
3 1/2	1/2	4 1/32	5 7/8	7 15/16	5/16	2 9/16	8 ga x 1 3/16	10 ga x 1 3/16	1350	114	25
4	5/8	4 1/8	5 15/16	8 3/16	3/8	2 1/8	8 ga x 1 3/16	10 ga x 1 3/16	1430	126	25
5	5/8	4 3/16	5 11/16	8 7/16	1/2	1 7/16	4 ga x 1 1/4	8 ga x 1 1/4	1430	204	25
6	3/4	5 1/16	6 13/16	10 1/8	1/2	1 3/4	3 ga x 1 1/2	8 ga x 1 1/2	1940	280	10
8	3/4	6 3/16	8 1/16	12 7/16	5/8	1 7/8	3 ga x 1 3/4	8 ga x 1 3/4	2000	446	10
10	7/8	7 3/4	10	15 7/16	3/4	2 1/4	3/8 x 1 3/4	3 ga x 1 3/4	3600	806	BULK
12	7/8	9 1/32	11 9/16	18	3/4	2 13/16	3/8 x 2	3 ga x 2	3800	1034	BULK
14	1	11 1/4	14 3/8	21 1/4	7/8	4 3/8	1/2 x 2	1/4 x 2	4200	1430	BULK
15	1	11 1/2	14 1/16	21 9/16	1	4 3/8	1/2 x 2 1/2	1/4 x 2 1/2	4600	2050	BULK
16	1	11 15/16	13 15/16	21 15/16	1	2 13/16	1/2 x 2 1/2	1/4 x 2 1/2	4600	2100	BULK
18*	1	13 7/8	16	25	1	3 3/4	1/2 x 2 1/2	1/4 x 2 1/2	4600	2440	BULK
20*	1 1/4	15 1/8	17 1/2	27 1/2	1 1/4	3 3/4	5/8 x 3	3/8 x 3	4800	4700	BULK
24*	1 1/4	16 5/16	19 3/4	31 3/4	1 1/4	3	5/8 x 3	3/8 x 3	4800	5800	BULK
30*	1 1/4	21 1/8	24 5/8	39 5/8	1 1/4	4 13/16	3/4 x 3	3/8 x 3	6000	7500	BULK
36*	1 1/2	28 1/4	32	50	1 1/2	6 3/4	3/4 x 6	1/2 x 6	9500	19700	BULK

\* fitted with pipe spacer on cross bolt.

Oversized Clevis Hanger Installations:

Note: A pipe spacer should be placed over the clevis bolt and blocks need to be placed on either side of the pipe until final installation is completed. Additionally all clevis hangers on the line need to take up their share of the pipe load prior to insulating to prevent hanger damage by overloading.



QWI 4.3.1 Issue Date Oct/17 Rev.17

Note: when referencing a printed copy of this specification page, please insure it is the latest version as found on our website at [www.taylorassociates.com](http://www.taylorassociates.com)



# #24L Clevis Hanger Extended

**Finishes:** Bare Metal, Zinc Plated, Hot Dipped Galvanized, Epoxy

**Materials:** Carbon Steel, Stainless Steel 304SS & 316SS

**Approvals:** Complies with MSS SP-58 and SP-69 (Type 1).

**Recommended:** Recommended for the suspension of insulated, stationary pipe lines allowing for vertical adjustment.



'B'  
Rod Take-Out  
Pipe center to bottom of hanger rod.  
'C'  
Pipe center to top of hanger.  
'D'  
Bottom of pipe to  
top of hanger

MODIFIED HANGERS ARE  
REQUIRED FOR INSULATION  
THICKER THAN THAT SHOWN  
IN THE SPECIFICATION DATA  
TABLE

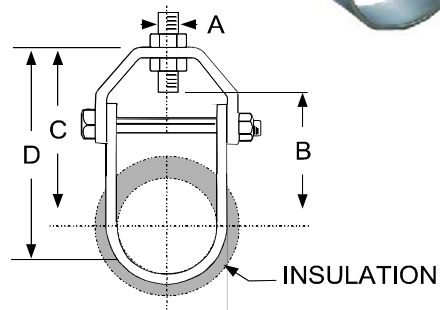

IRON PIPE SIZE	SPECIFICATION DATA						MAX. INSULATION THK.	REC. MAX LOAD (LBS.)	APP'X WT. PER 100 (LBS)	PC'S PER PKG.
	A	B	C	D	UPPER	LOWER				
3/4	3/8	2 7/8	3 5/8	4 1/4	11 ga x 1	11 ga x 1	2"	730	50	50
1	3/8	3 1/4	4	4 11/16	11 ga x 1	11 ga x 1	2"	730	57	50
1 1/4	3/8	3 5/8	4 7/16	5 1/4	11 ga x 1	11 ga x 1	2"	730	63	50
1 1/2	3/8	4 1/16	4 3/4	5 3/4	11 ga x 1	11 ga x 1	2"	730	71	25
2	3/8	6 1/2	7 7/16	8 11/16	11 ga x 1	11 ga x 1	4"	730	84	25
2 1/2	1/2	7 1/2	8 7/16	9 15/16	7 ga x 1 1/4	7 ga x 1 1/4	4"	1350	189	25
3	1/2	7 9/16	8 5/8	10 5/16	7 ga x 1 1/4	7 ga x 1 1/4	4"	1350	199	20
4	5/8	8 3/16	9 3/8	11 5/8	1/4 x 1 1/4	7 ga x 1 1/4	4"	1430	245	10
5	5/8	8 3/4	9 7/8	12 5/8	1/4 x 1 1/4	7 ga x 1 1/4	4"	1430	298	10
6	3/4	9 3/8	10 5/8	14	1/4 x 1 1/2	7 ga x 1 1/2	4"	1940	336	10
8	3/4	11	12 3/8	16 3/4	1/4 x 1 3/4	7 ga x 1 3/4	4"	2000	670	10
10	7/8	12 1/4	13 3/4	19 3/16	3/8 x 1 3/4	1/4 x 1 3/4	4"	3600	1100	BULK
12	7/8	13 5/8	15 1/8	21 9/16	3/8 x 2	1/4 x 2	4"	3800	1380	BULK



QWI 4.3.1 Issue Date Oct/17 Rev.6

Note: when referencing a printed copy of this specification page, please insure it is the latest version as found on our website at [www.taylorassociates.com](http://www.taylorassociates.com)

For more information, please contact Customer Service at 1-800-263-8652

# #27AC Adjustable Clevis Hanger - Oversized

**Finishes:** Bare Metal, Zinc Plated

**Materials:** Carbon Steel, Stainless Steel 304SS & 316SS

**Approvals:** Complies with MSS SP-58 and SP-69 (Type 1).

**Recommended:** Recommended for the suspension of stationary ductile iron or cast iron pipe

Maximum temperatures: Bare Metal 650°F, Galvanized 450°F

**Note:** For sizes 12" and larger, a spacer is added over cross bolt.  
For use with:

AWWA Cast iron Pipe  
Ductile Iron Pipe  
Asbestos Cement / Transite Pipe

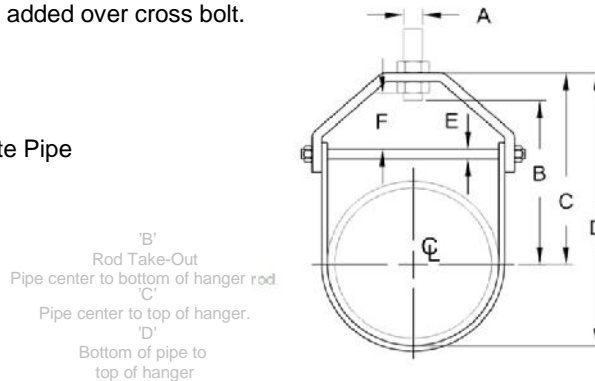

PIPE SIZE	SPECIFICATION DATA							REC. MAX LOAD (LBS.)	APP'X WT. PER 100 (LBS)	PC'S PER PKG.	
	A	B	C	D	E	F	UPPER				LOWER
3	1/2	3 3/4	5 5/16	7 5/16	1/2	1 15/16	8 ga x 1 1/4	11 ga x 1 1/4	1130	156	25
4	5/8	4 3/16	5 13/16	8 1/4	1/2	1 11/16	1/4 x 1 1/4	8 ga x 1 1/4	1430	203	15
6	3/4	5 3/8	7 1/4	10 5/8	1/2	1 3/4	5/16 x 1 1/2	7 ga x 1 1/2	1940	375	15
8	3/4	6 15/16	9 1/2	14	5/8	2 13/16	3/8 x 1 1/2	1/4 x 1 1/2	2000	571	BULK
10	7/8	8 1/2	10 3/4	16 1/2	3/4	2 5/8	3/8 x 2	1/4 x 2	3600	963	BULK
12	7/8	9	12 1/8	19	3/4	2 7/8	3/8 x 2	1/4 x 2	3800	1152	BULK
14	1	11 3/4	13 1/2	21 1/2	1	2 1/2	1/2 x 2	1/4 x 2	4200	1757	BULK
16	1	13 1/2	15 1/4	24 1/4	1	3 3/8	1/2 x 2 1/2	1/4 x 2 1/2	4600	2538	BULK
18	1	14 7/8	16 3/4	26 3/4	1 1/4	3 3/8	1/2 x 2 1/2	1/4 x 2 1/2	4800	4700	BULK
20	1 1/4	16 3/8	18 1/2	29 3/4	1 1/4	3 3/4	5/8 x 3	3/8 x 3	4800	5050	BULK
24	1 1/4	18 5/8	20 3/4	34	1 1/4	4	5/8 x 3	3/8 x 3	4800	5800	BULK

NOMINAL PIPE SIZE	PIPE O.D.	
	AWWA DUCTILE PIPE	AC/TRANSITE PIPE
3	3.96	4.02
4	4.80	4.96
6	6.90	7.17
8	9.05	9.61
10	11.10	11.18
12	13.20	13.15



OWI 4.3.1 Issue Date Mar/18 Rev.16

Note: when referencing a printed copy of this specification page, please insure it is the latest version as found on our website at [www.taylorassociates.com](http://www.taylorassociates.com)

For more information, please contact Customer Service at 1-800-263-8652

## CLEVIS HANGER Epoxy Coated Copper-Gard #52

- 1/2" through 6"
- Carbon Steel
- Epoxy Coated Copper-Gard c/w Zinc Hardware
- Complies with MSS SP-58 and SP-69 (Type 1).
- Recommended for the suspension of copper tubing, stationary pipe lines allowing for vertical adjustment.
- Specify pipe size, figure number and name.



'B'  
Rod Take-Out  
Pipe center to bottom of hanger rod.  
'C'  
Pipe center to top of hanger.  
'D'  
Bottom of pipe to  
top of hanger

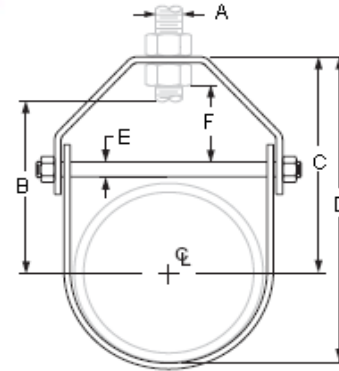

COPPER TUBE SIZE	SPECIFICATION DATA							REC. MAX. LOAD (LBS.)	APP'X WT. PER 100 (LBS)	PC'S PER PKG.	
	A	B	C	D	E	F	UPPER				LOWER
1/2	3/8	1 1/4	1 15/16	2 1/4	1/4	21/32	18 ga x 7/8	18 ga x 7/8	150	13	100
3/4	3/8	1 1/8	1 3/4	2 3/16	1/4	9/16	18 ga x 7/8	18 ga x 7/8	150	13	100
1	3/8	1 5/32	1 25/32	2 5/16	1/4	1/2	18 ga x 7/8	18 ga x 7/8	250	14	100
1 1/4	3/8	1 1/4	2 1/16	2 3/4	1/4	13/16	18 ga x 7/8	18 ga x 7/8	250	17	100
1 1/2	3/8	1 21/32	2 1/2	3 5/16	1/4	15/16	18 ga x 7/8	18 ga x 7/8	250	20	100
2	3/8	1 15/16	2 7/8	3 15/16	1/4	1 1/32	14 ga x 7/8	14 ga x 7/8	250	38	50
2 1/2	1/2	2 3/8	3 9/16	4 7/8	1/4	1 1/4	11 ga x 1 1/4	11 ga x 1 1/4	350	66	50
3	1/2	2 17/32	3 5/8	5 3/16	1/4	1 1/16	11 ga x 1 1/4	11 ga x 1 1/4	350	75	50
4	1/2	3 3/8	4 9/16	6 5/8	5/16	1 1/4	11 ga x 1 1/4	11 ga x 1 1/4	400	99	25
5	5/8	3 15/16	5 5/16	7 7/8	3/8	1 3/8	8 ga x 1 1/2	8 ga x 1 1/2	800	110	25
6	5/8	4 3/4	6 3/16	9 1/4	3/8	1 1/2	8 ga x 1 1/2	8 ga x 1 1/2	1000	125	25



QWI 4.3.1 Issue Date Aug/16 Rev.6

*Note: when referencing a printed copy of this specification page please insure it is the latest version as found on our website at [www.taylorassociates.com](http://www.taylorassociates.com)*



# #25 MJ Hanger

**Finishes:** Bare Metal, Zinc Plated

**Material:** Carbon Steel

**Recommended:** Recommended for the suspension of no hub or service weight cast iron pipe.

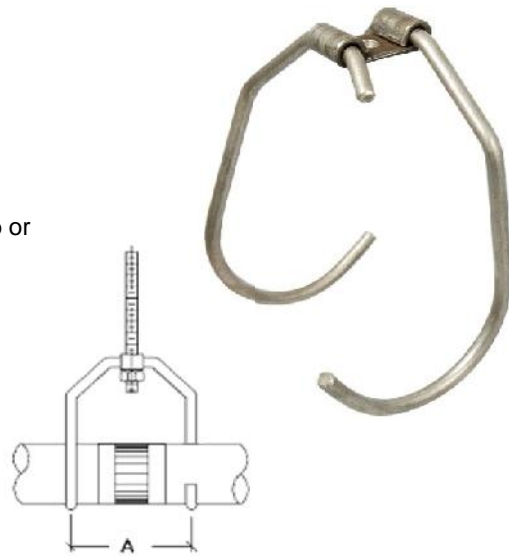

IRON PIPE SIZE	SPECIFICATION DATA	MAXIMUM RECOMMENDED LOAD (lbs)	APP'X WT. PER 100 (LBS.)
	DIMENSION "A"		
2	4 1/4	598	61
3	4 1/2	598	68
4	5 1/8	598	78
6	6	1108	210



QWI 4.3.1 Issue Date May/18 Rev.4

Note: when referencing a printed copy of this specification page, please insure it is the latest version as found on our website at [www.taylorassociates.com](http://www.taylorassociates.com)

For more information, please contact Customer Service at 1-800-263-8652

# RUBBER IN SHEAR HANGER

## (NHD Series Double Deflection)

**NHD** Series Hangers are neoprene elements housed in sturdy steel brackets. The element includes top and bottom steel plates for uniform load distribution. All elements are color coded for easy identification. The element incorporates a projected collar to prevent metal to metal contact between the rod and bracket. The NHD series hangers are used for hanging machines such as fan coil units, fans etc.

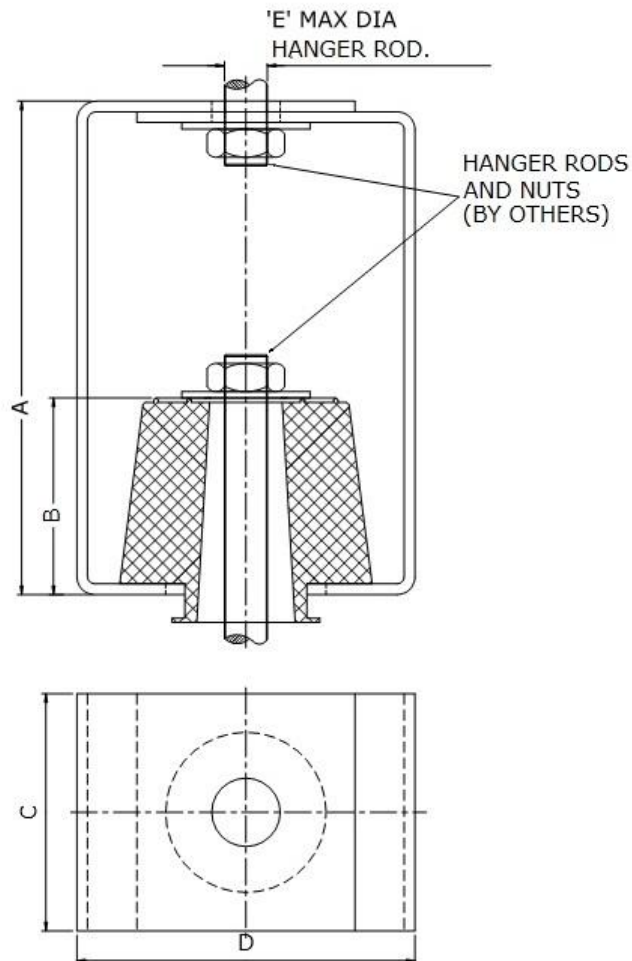

### NOTES:

- Bracket: Blue Powder Coated
- Hanger Rods and Nuts not included
- DO NOT exceed maximum load by more than 5.0 %
- Model dimensions and details listed on next page

### FEATURES:

- Steel Plates are embedded in the element for uniform loading
- Element is oil and water resistant

HANGER MODEL	MAX LOAD (LBS)	DEFLECTION (INCHES)	HANGER DIMENSIONS (INCHES)					COLOR
			A	B	C	D	E	
NHD-1-A	30	0.4	3	1-3/8	2	2-1/4	3/8	BLUE
NHD-1-B	40	0.4	3	1-3/8	2	2-1/4	3/8	RED
NHD-1-C	70	0.4	3	1-3/8	2	2-1/4	3/8	GREEN
NHD-1-D	115	0.4	3	1-3/8	2	2-1/4	3/8	BLACK
NHD-2-A	165	0.5	4-1/2	1-7/8	2-1/4	3	1/2	BLUE
NHD-2-B	235	0.5	4-1/2	1-7/8	2-1/4	3	1/2	RED
NHD-2-C	375	0.5	4-1/2	1-7/8	2-1/4	3	1/2	GREEN
NHD-2-D	545	0.5	4-1/2	1-7/8	2-1/4	3	1/2	BLACK
NHD-3-C	745	0.5	6	3-1/8	3-1/2	4	1/2	GREEN
NHD-3-D	1245	0.5	6	3-1/8	3-1/2	4	1/2	BLACK
NHD-4-B	2240	0.5	6	3-1/8	4	4-1/2	5/8	RED
NHD-4-C	3000	0.5	6	3-1/8	4	4-1/2	5/8	GREEN
NHD-4-D	4000	0.5	6	3-1/8	4	4-1/2	5/8	BLACK

# SPRING HANGERS

## (SH- Series 3/4" Deflection)

SH series spring hangers are steel springs housed in rectangular steel brackets. The assembly incorporates dual (Steel and Elastomer) washers for uniform load distribution and high frequency isolation. These spring hangers are normally used in critical areas where noise and vibration need to be controlled.

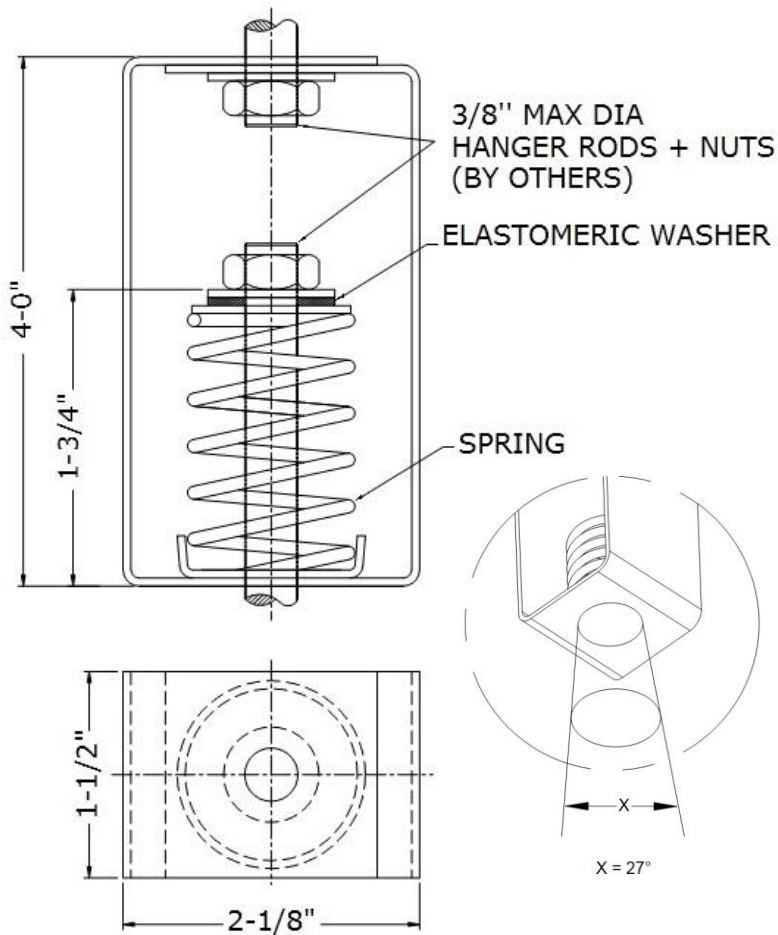

### NOTES:

- Bracket: Blue Powder Coated
- Spring: Hot Dip Galvanized
- Design allows angular hanger misalignment
- Hanger Rods and Nuts not included

### APPLICATIONS:

- Fan Coil Units
- Air Handling Units
- Fans
- Pipes
- Ducts

ISOLATOR MODEL	RATED LOAD (LBS)	RATED DEFLECTION (INCH)	COLOR	
			MAIN	STRIPE
SH-011	30	0.75	SILVER	BLUE
SH-012	66	0.75	SILVER	RED
SH-013	105	0.75	SILVER	YELLOW
SH-014	150	0.75	SILVER	WHITE
SH-015	225	0.75	SILVER	BLACK

# SPRING HANGERS

## (SHA Series $\frac{3}{4}$ " Deflection)

SHA series spring hangers are steel springs housed in rectangular steel brackets. The assembly incorporates dual (Steel and Elastomer) washers for uniform load distribution and high frequency isolation. These spring hangers are normally used in critical areas where noise and vibration need to be controlled.

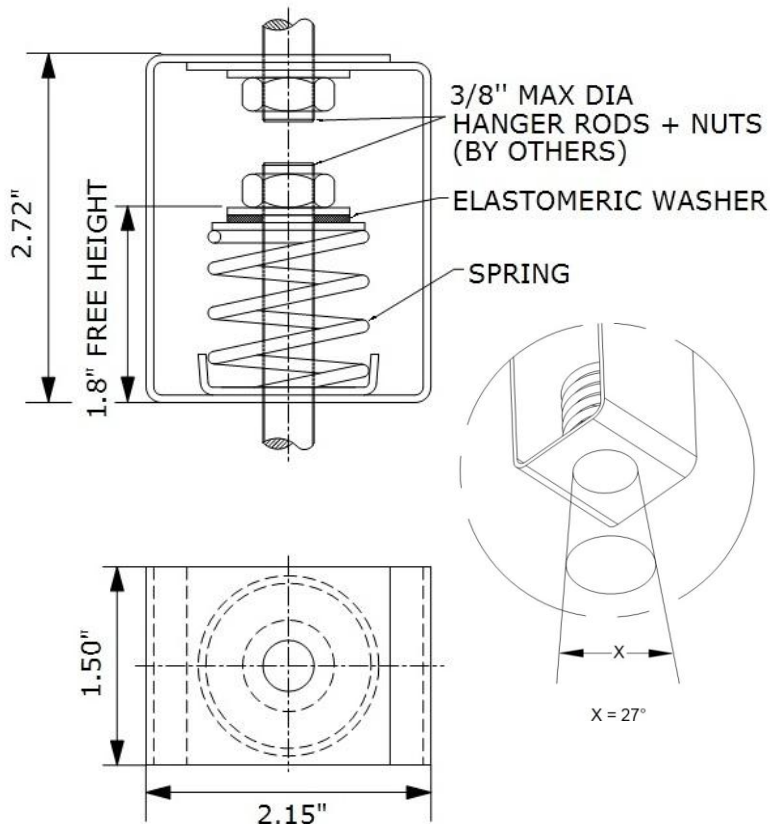

### NOTES:

- Bracket: Powder Coated
- Spring: Hot Dip Galvanized
- Design allows angular hanger misalignment
- Hanger Rods and Nuts not included

### APPLICATIONS:

- Fan Coil Units
- Air Handling Units
- Fans
- Pipes
- Ducts

ISOLATOR MODEL	RATED LOAD (LBS)	RATED DEFLECTION (INCH)	COLOR	
			MAIN	STRIPE
SHA-011	30	0.75	SILVER	BLUE
SHA-012	66	0.75	SILVER	RED
SHA-013	105	0.75	SILVER	YELLOW
SHA-014	150	0.75	SILVER	WHITE
SHA-015	225	0.75	SILVER	BLACK



# SPRING HANGERS

## (SHB- 100 Series 1" Deflection)

SHB series spring hangers are large diameter steel springs housed in rectangular steel brackets. The assembly incorporates dual (Steel and Elastomer) washers for uniform load distribution and high frequency isolation. These spring hangers are normally used in critical areas where noise and vibration need to be controlled.

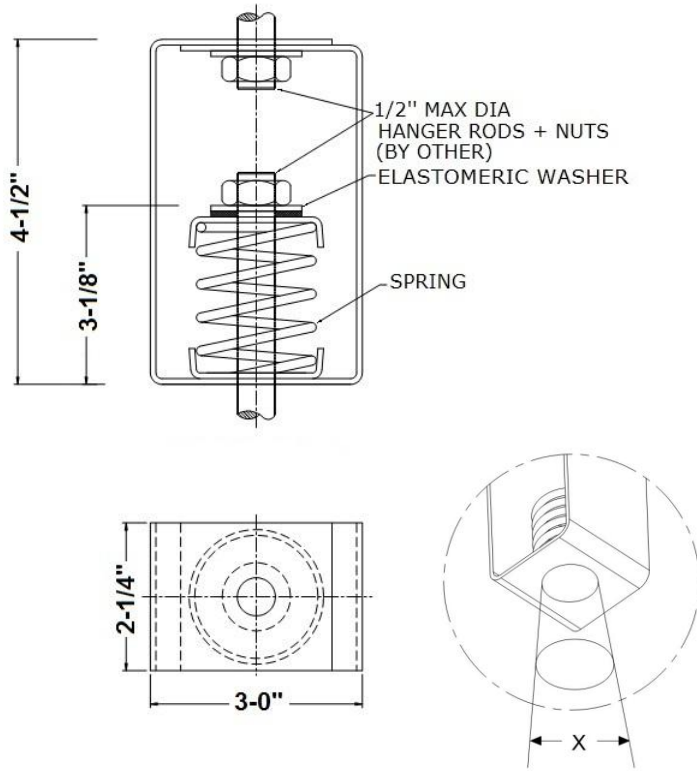

X = 46° For Spring 101 to 107



### NOTES:

- Bracket: Blue Powder Coated
- Spring: Hot Dip Galvanized
- Design allows angular hanger misalignment
- Hanger Rods and Nuts not included

### APPLICATIONS:

- Fan Coil Units
- Air Handling Units
- Fans
- Pipes
- Ducts

ISOLATOR MODEL	RATED LOAD (LBS)	RATED DEFLECTION (INCH)	COLOR	
			MAIN	STRIPE
SHB-101	60	1.3	SILVER	BLUE
SHB-102	100	1.3	SILVER	ORANGE
SHB-103	165	1.2	SILVER	BROWN
SHB-104	260	1.0	SILVER	BLACK
SHB-105	370	0.8	SILVER	YELLOW
SHB-106	450	0.5	SILVER	RED
SHB-107	700	0.45	SILVER	GREEN

# SPRING HANGERS

## (SHC- 100 Series 1" Deflection)

SHC series spring hangers are large diameter steel springs housed in rectangular steel brackets. The assembly incorporates dual (Steel and Elastomer) washers for uniform load distribution and high frequency isolation. These spring hangers are normally used in critical areas where noise and vibration need to be controlled.

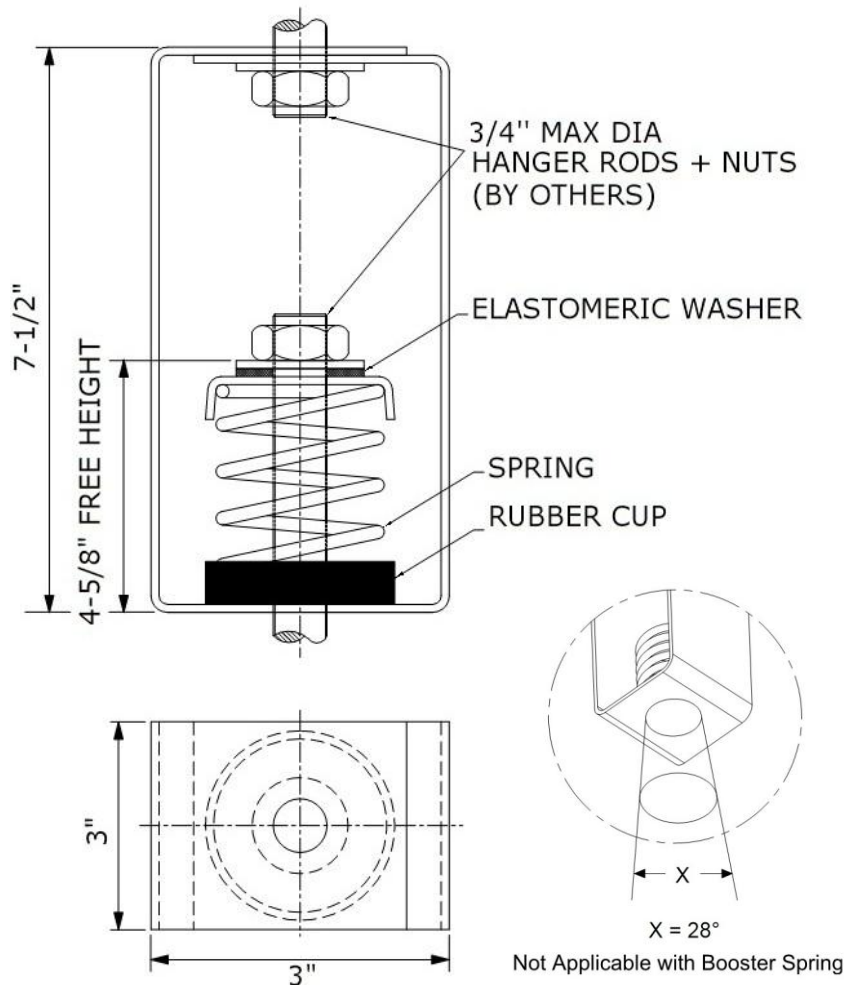

### NOTES:

- Bracket: Blue Powder Coated
- Spring: Hot Dip Galvanized
- Bottom Cup with Collar: Neoprene
- Hanger Rods and Nuts not included
- Design allows angular hanger misalignment

### APPLICATIONS:

- Fan Coil Units
- Air Handling Units
- Fans
- Pipes
- Ducts

ISOLATOR MODEL	RATED LOAD (LBS)	RATED DEFLECTION (INCH)	COLOR	
			MAIN	STRIPE
SHC-111	85	1.4	SILVER	PINK
SHC-112	115	1.3	SILVER	BLACK
SHC-113	170	1.3	SILVER	BLUE
SHC-114	225	1.3	SILVER	YELLOW
SHC-115	325	1.2	SILVER	BROWN
SHC-116	450	1.2	SILVER	RED
SHC-117	600	1.2	SILVER	PURPLE
SHC-118	750	1.1	SILVER	ORANGE
SHC-119	900	1.0	SILVER	GREEN
SHC-120	1100	0.8	SILVER	GRAY
SHC-121	1300	0.8	SILVER	WHITE
SHC-122	1500	1.0	SILVER	GOLD
SHC-111-123	761	1.0	SILVER/SILVER	PINK/NIL
SHC-112-123	789	1.0	SILVER/SILVER	BLACK/NIL
SHC-113-123	831	1.0	SILVER/SILVER	BLUE/NIL
SHC-114-123	874	1.0	SILVER/SILVER	YELLOW/NIL
SHC-115-123	971	1.0	SILVER/SILVER	BROWN/NIL
SHC-116-123	1075	1.0	SILVER/SILVER	RED/NIL
SHC-117-123	1200	1.0	SILVER/SILVER	PURPLE/NIL
SHC-118-123	1382	1.0	SILVER/SILVER	ORANGE/NIL
SHC-119-123	1600	1.0	SILVER/SILVER	GREEN/NIL
SHC-120-123	1660	0.8	SILVER/SILVER	GRAY/NIL
SHC-121-123	1860	0.8	SILVER/SILVER	WHITE/NIL
SHC-122-123	2200	1.0	SILVER/SILVER	GOLD/NIL

# SPRING HANGERS

## (SHC- 200 Series 2" Deflection)

SHC series spring hangers are large diameter steel springs housed in rectangular steel brackets. The assembly incorporates dual (Steel and Elastomer) washers for uniform load distribution and high frequency isolation. These spring hangers are normally used in critical areas where noise and vibration need to be controlled.

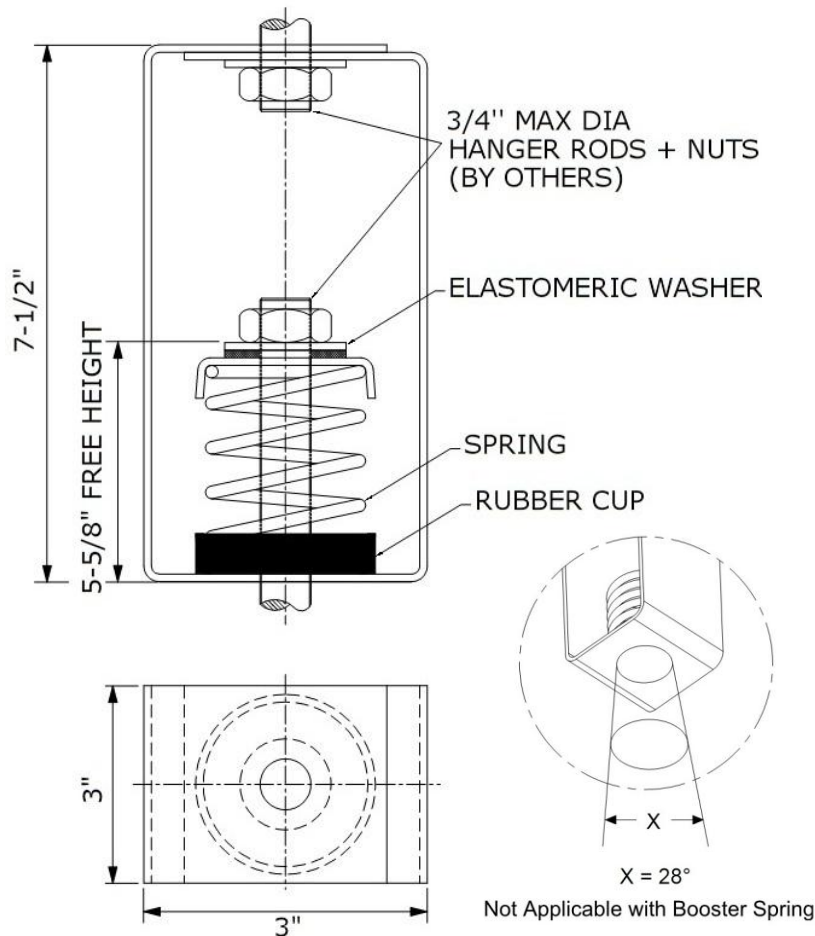

### NOTES:

- Bracket: Blue Powder Coated
- Spring: Hot Dip Galvanized
- Bottom Cup: Neoprene
- Design allows angular hanger misalignment
- Hanger Rods and Nuts not included

### APPLICATIONS:

- Fan Coil Units
- Air Handling Units
- Fans
- Pipes
- Ducts

HANGER MODEL	RATED LOAD (LBS)	RATED DEFLECTION (INCH)	COLOR	
			MAIN	STRIPE
SHC-200	100	2.25	SILVER	BLUE
SHC-201	200	2.25	SILVER	BLACK
SHC-202	375	2.0	SILVER	RED
SHC-203	500	2.0	SILVER	GREEN
SHC-204	714	2.0	SILVER	GRAY
SHC-205	1430	2.0	SILVER	WHITE
SHC-207	1892	2.0	SILVER	YELLOW
SHC-200-206	690	2.0	SILVER	BLUE
SHC-201-206	778	2.0	SILVER	BLACK
SHC-202-206	976	2.0	SILVER	RED
SHC-203-206	1100	2.0	SILVER	GREEN
SHC-204-206	1314	2.0	SILVER	GRAY
SHC-205-206	2030	2.0	SILVER	WHITE
SHC-207-206	2492	2.0	SILVER	YELLOW

# SPRING HANGERS

## (SHD- 100 Series 1" Deflection)

SHD series spring hangers are large diameter steel springs housed in rectangular steel brackets. The assembly incorporates dual (Steel and Elastomer) washers for uniform load distribution and high frequency isolation. These spring hangers are normally used in critical areas where noise and vibration need to be controlled.

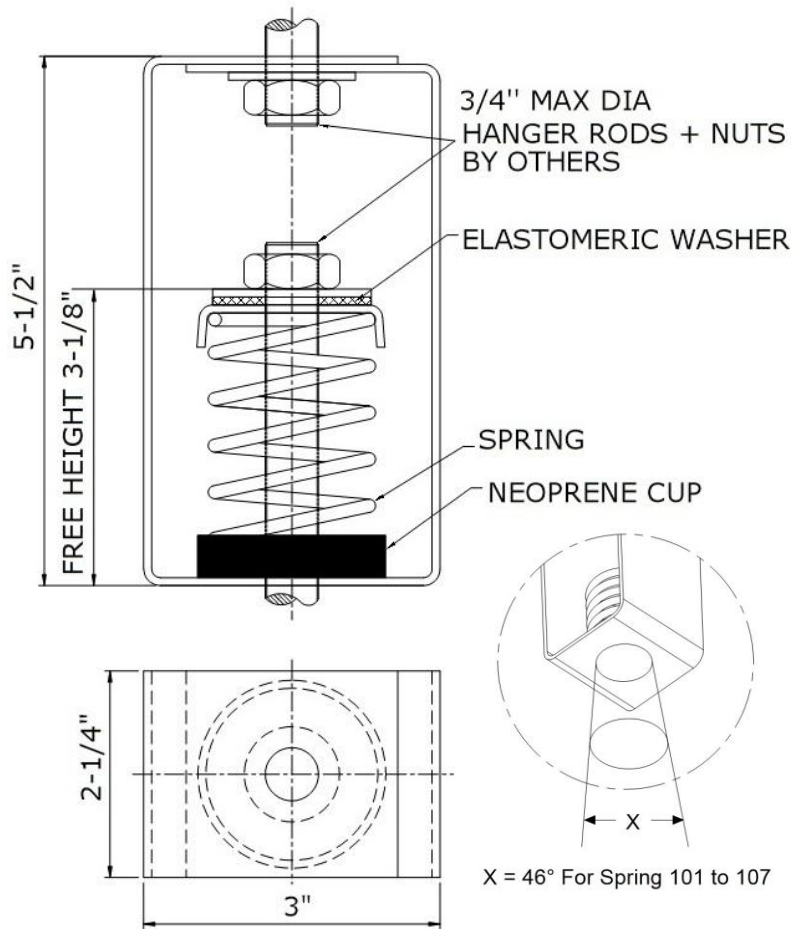

### NOTES:

- Bracket: Blue Powder Coated
- Spring: Hot Dip Galvanized
- Bottom Cup: Neoprene
- Design allows angular hanger misalignment
- Hanger Rods and Nuts not included

### APPLICATIONS:

- Fan Coil Units
- Air Handling Units
- Fans
- Pipes
- Ducts

ISOLATOR MODEL	RATED LOAD (LBS)	RATED DEFLECTION (INCH)	COLOR	
			MAIN	STRIPE
SHD-101	60	1.3	SILVER	BLUE
SHD-102	100	1.3	SILVER	ORANGE
SHD-103	165	1.2	SILVER	BROWN
SHD-104	260	1.0	SILVER	BLACK
SHD-105	370	0.8	SILVER	YELLOW
SHD-106	450	0.5	SILVER	RED
SHD-107	700	0.45	SILVER	GREEN



### SPRING CUSHION HANGER #178

- Spring Size 1 through 3
- Carbon Steel
- Consists of a set of two springs and four retaining plates only.
- **Note:** Order hangers separately.
- Used where piping is subject to negligible vertical movement but where a protective cushioning action is required.  
When used with Fig. 95 Roller Hanger as illustrated, an excellent flexible support is provided for horizontal steam or hot water
- Specify spring size, Dimension "A", figure number and name.

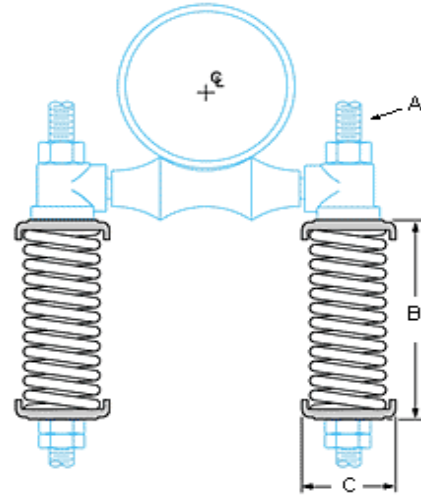
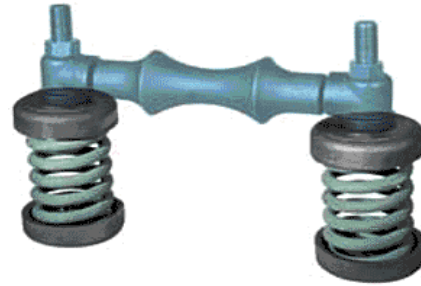

SPRING SIZE	SPECIFICATION DATA			Max. Pipe Load LB	Deflection Rate LB/IN	Max Spring Deflection (IN) From Free Height	Approx. Wt Per 100
	A	B Unloaded	C				
1	3/8	6 3/4	3 1/2	535	428	1 1/4	450
2	1/2	6 1/4	4 1/2	1500	1200	1 1/4	1400
3	7/8	9 3/8	4 1/2	3000	2400	1 1/4	2200

Loads and deflections are per set (two springs)



QWI 4.3.1 Issue Date Mar/09 Rev.0

*Note: when referencing a printed copy of this specification page please insure it is the latest version as found on our website at [www.taylorassociates.com](http://www.taylorassociates.com)*

**PIPE STAY - Standard #32S**

- 1/2" - 2" Copper / 3/8" - 2" Iron Pipe
- Carbon Steel
- Epoxy Coated
- Vertical or horizontal offset pipe guide
- Specify pipe size, figure number, name and finish.
- Also available in Stainless Steel 304 (SS4)

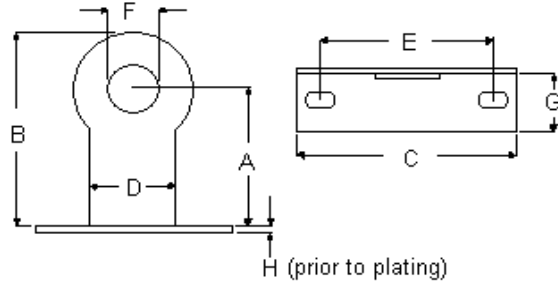

TAYLOR #	PIPE SIZE	SPECIFICATION DATA								FASTENER OPTIONS		APPR'X WT PER 100 (LBS)	PC'S PER PKG.
		A	B	C	D	E	F	G	H	WOOD SCREW	LAG SCREW		
32-01	1/2C X 3/8IP	1 1/8	1 13/16	2 1/2	1	1 3/4	11/16	3/4	16Ga	# 10	# 10	8	100
32-02	3/4C X 1/2IP	1 3/16	1 7/8	2 1/2	1	1 3/4	29/32	3/4	16Ga	# 10	# 10	8	100
32-03	1C X 3/4IP	1 1/2	2 7/16	3 1/4	1 1/4	2	1 5/32	3/4	16Ga	# 14	1/4"	11	100
32-04	1 1/4C X 1IP	1 1/2	2 9/16	3 1/4	1 1/4	2	1 13/32	3/4	16Ga	# 14	1/4"	16	100
32-05	1 1/2C X 1 1/4IP	2 1/2	3 5/8	4	1 3/4	3	1 23/32	15/16	14Ga	# 16	1/4"	20	100
32-06	1 1/2IP	2 5/8	4 3/16	4 1/2	2 3/16	3 1/4	1 31/32	1 1/16	14Ga	# 16	1/4"	24	50
32-07	2IP	2 11/16	4 3/16	4 1/2	2 3/16	3 1/4	2 7/16	1 1/16	14Ga	# 16	1/4"	30	50
32-08	2C	2 11/16	4 3/16	4 1/2	2 3/16	3 1/4	2 3/16	1 1/16	14Ga	# 16	1/4"	30	50



QWI 4.3.1 Issue Date Aug/16 Rev.7

*Note: when referencing a printed copy of this specification page please insure it is the latest version as found on our website at [www.taylorassociates.com](http://www.taylorassociates.com)*

### PIPE STAY - Extended #32E

- 1/2" - 1 1/4" Copper / 3/8" - 1" Iron Pipe
- Carbon Steel
- Epoxy Coated
- Vertical or horizontal offset pipe guide
- Specify pipe size, figure number, name and finish.
- Also available in Stainless Steel 304 (SS4)

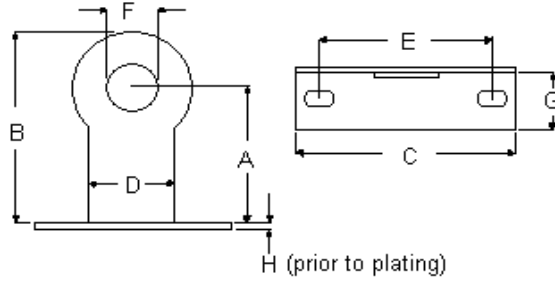

TAYLOR #	PIPE SIZE	SPECIFICATION DATA								FASTENER OPTIONS		APPR'X WT PER 100 (LBS)	PC'S PER PKG.
		A	B	C	D	E	F	G	H	WOOD SCREW	LAG SCREW		
32-09	1/2C X 3/8IP	2 1/2	3 1/8	2 1/2	1	1 3/4	11/16	3/4	16Ga	# 10	# 10	10	100
32-10	3/4C X 1/2IP	2 1/2	3 1/4	2 1/2	1	1 3/4	29/32	3/4	16Ga	# 10	# 10	10	100
32-11	1C X 3/4IP	2 11/16	3 9/16	3 1/4	1 1/4	2	1 5/32	3/4	14Ga	# 14	1/4"	15	100
32-12	1 1/4C X 1IP	2 11/16	3 11/16	3 1/4	1 1/4	2	1 13/32	25/32	14Ga	# 14	1/4"	18	100



QWI 4.3.1 Issue Date Aug/16 Rev.6

*Note: when referencing a printed copy of this specification page please insure it is the latest version as found on our website at [www.taylorassociates.com](http://www.taylorassociates.com)*

### PIPE STAY - Double #32D

- 1/2" - 3/4" Copper / 3/8" - 1/2" Iron Pipe
- Carbon Steel
- Epoxy Coated
- Vertical or horizontal offset pipe guide
- Specify pipe size, figure number, name and finish.

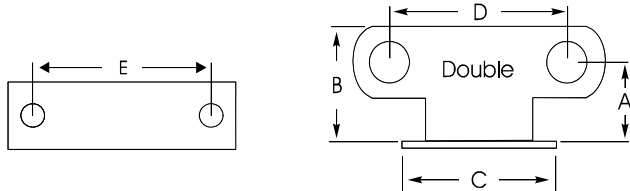

TAYLOR #	PIPE SIZE	SPECIFICATION DATA					FASTENER OPTIONS		APPR'X WT PER 100 (LBS)	PC'S PER PKG.
		A	B	C	D	E	WOOD SCREW	LAG SCREW		
32-13	1/2C X 3/8IP	1 3/16	1 7/8	2 1/2	3	1 3/4	# 10	# 10	11	50
32-14	3/4C X 1/2IP	1 3/16	1 7/8	2 1/2	3	1 3/4	# 10	# 10	11	50



QWI 4.3.1 Issue Date Aug/16 Rev.2

*Note: when referencing a printed copy of this specification page please insure it is the latest version as found on our website at [www.taylorassociates.com](http://www.taylorassociates.com)*

**ONE HOLE PIPE STRAP #44**

- 1/4" through 2"
- Carbon Steel
- Pre-Galvanized Zinc
- Recommended for the support of light duty conduit on walls or sides of beams. Not recommended for supporting pipe on ceilings or similar horizontal surfaces.
- Specify pipe size, figure number, name and finish.
- Also available in Stainless Steel and O.D. Sizes



IRON PIPE SIZE	SPECIFICATION DATA		APP'X WT. PER 100 (LBS)	PC'S PER PKG.
	HOLE DIAMETER			
1/4	7/32		2	100
3/8	7/32		2	100
1/2	9/32		6	100
3/4	9/32		7	100
1	13/32		15	50
1 1/4	13/32		19	25
1 1/2	13/32		20	25
2	13/32		38	25



QWI 4.3.1 Issue Date Mar/12 Rev.6

*Note: when referencing a printed copy of this specification page please insure it is the latest version as found on our website at [www.taylorassociates.com](http://www.taylorassociates.com)*

## 2-HOLE PIPE STRAP #45

- 1/2" through 6"
- Carbon Steel
- Pre-Galvanized
- Complies with MSS SP-58 and SP-69 (Type 26).
- Recommended for the support of light duty conduit on walls or sides of beams. Not recommended for supporting pipe on ceilings or similar horizontal surfaces.
- Specify pipe size, figure number, name and finish.
- Also available in Hot Dipped Galvanized



IRON PIPE SIZE	SPECIFICATION DATA	APP'X WT. PER 100 (LBS)	PC'S PER PKG.
	MATERIAL		
1/2	21 ga x 3/4"	3	100
3/4	21 ga x 3/4"	5	100
1	20 ga x 1	8	100
1 1/4	20 ga x 1	9	100
1 1/2	17 ga x 1	11	100
2	15 ga x 1	13	100
2 1/2	14 ga x 1	15	50
3	13 ga x 1	16	50
4	12 ga x 1	39	50
5	16 ga x 1 1/4	46	25
6	16 ga x 1 1/4	51	25



QWI 4.3.1 Issue Date Mar/12 Rev.7

*Note: when referencing a printed copy of this specification page please insure it is the latest version as found on our website at [www.taylorassociates.com](http://www.taylorassociates.com)*



## 2-HOLE PIPE STRAP Epoxy Coated Copper-Gard #45C

- 1/2" through 2"
- Carbon Steel
- Epoxy Coated Copper-Gard c/w Copper Plated Nails
- Complies with MSS SP-58 and SP-69 (Type 26).
- Recommended for the support of light duty copper tubing on walls or sides of beams. Not recommended for supporting pipe on ceilings or similar horizontal surfaces.
- Specify tube size, figure number, name and finish.



COPPER TUBE SIZE	SPECIFICATION DATA		APP'X WT. PER 100 (LBS)	PC'S PER PKG.
	MATERIAL			
1/2	20 ga x 1/2"		1	100
3/4	20 ga x 1/2"		2	100
1	20 ga x 1/2"		2	100
1 1/4	20 ga x 1/2"		4	100
1 1/2	18 ga x 3/4"		5	100
2	18 ga x 3/4"		6	100



QWI 4.3.1 Issue Date Aug/16 Rev.4

*Note: when referencing a printed copy of this specification page please insure it is the latest version as found on our website at [www.taylorassociates.com](http://www.taylorassociates.com)*

## #45 SS TWO HOLE PIPE STRAP

**Material:** 304 Stainless Steel  
alt: 316 Stainless Steel

**Finish:** N/A

**Approvals:** Complies with MSS SP-58 and SP-69 (Type 26).

**Recommended:** to support light duty pipe or tubing to walls or sides of beams

**Notes:** Not recommended for hanging from ceilings

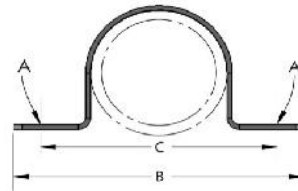

Pipe Size	Pipe OD	A	B	C	Material
<b>1/4</b>	.540	3/16	2 1/16	1 7/16	20 ga x 5/8
<b>1/4 OD</b>	.250	3/16	1 3/4	1 1/8	20 ga x 5/8
<b>3/8</b>	.675	3/16	2 3/16	1 9/16	20 ga x 5/8
<b>3/8OD</b>	.375	3/16	1 7/8	1 1/4	20 ga x 5/8
<b>1/2</b>	.840	3/16	2 5/16	1 3/4	20 ga x 5/8
<b>1/2OD</b>	.500	3/16	2	1 3/8	20 ga x 5/8
<b>3/4</b>	1.050	3/16	2 5/8	1	20 ga x 5/8
<b>3/4OD</b>	.750	3/16	2 1/4	1 5/8	20 ga x 5/8
<b>1</b>	1.315	3/16	2 13/16	2 3/16	20 ga x 5/8
<b>1OD</b>	1.0	3/16	2 1/2	1 7/8	20 ga x 5/8
<b>1 1/4</b>	1.660	9/32	3 21/32	2 27/32	16 ga x 1
<b>1 1/4OD</b>	1.250	9/32	3 1/4	2 7/16	16 ga x 1
<b>1 1/2</b>	1.90	9/32	3 29/32	3 3/32	16 ga x 1
<b>1 1/2OD</b>	1.50	9/32	3 1/2	2 11/16	16 ga x 1
<b>2</b>	2.375	9/32	4 3/8	3 9/16	16 ga x 1
<b>2OD</b>	2.0	9/32	4	3 3/16	16 ga x 1
<b>2 1/2</b>	2.875	11/32	5 1/4	4 1/4	13 ga x 3/4
<b>3</b>	3.500	11/32	6	5	13 ga x 3/4
<b>4</b>	4.500	7/16	7 1/4	6 1/4	11 ga x 1

QWI 4.3.1 Issue Date April/17 Rev. 1

Note: If details and dimensions are critical to your application please insure you are referencing the most recent version of this specification sheet from our website.



## #46 HOLD DOWN CLAMP

**Finish:** Bare Metal

*alt: Zinc Plated, Hot Dipped Galvanized*

**Material:** Carbon Steel

*alt: Stainless Steel 304 and 316*

**Approvals:** Complies with MSS SP-58  
and SP-69 (Type 26).

**Recommended:** Designed to steady a horizontal run  
of pipe against a perpendicular  
section of strut channel or any  
other flat surface

**Notes:**

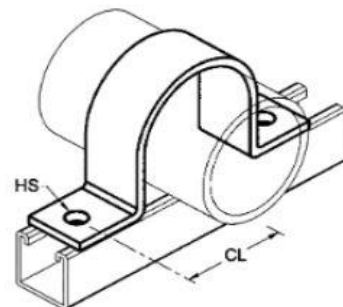
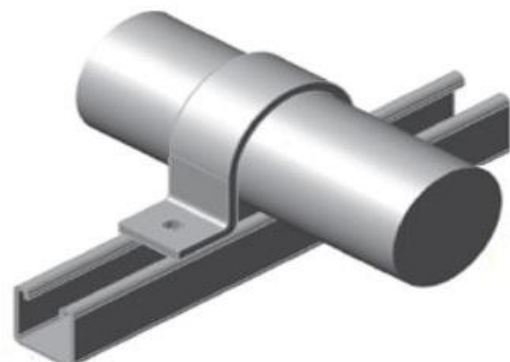

Iron Pipe Size	SPECIFICATION DATA			Weight Each (Lbs)
	HS (Hole Size)	CL	MATERIAL	
1/2	5/16	15/16	1/8 x 1 5/8	0.23
3/4	5/16	1	1/8 x 1 5/8	0.26
1	5/16	1 1/8	1/8 x 1 5/8	0.31
1 1/4	5/16	1 5/16	1/8 x 1 5/8	0.35
1 1/2	5/16	1 7/16	1/8 x 1 5/8	0.39
2	7/16	2 1/8	1/4 x 1 5/8	0.94
2 1/2	7/16	2 3/8	1/4 x 1 5/8	1.14
3	7/16	2 11/16	1/4 x 1 5/8	1.33
3 1/2	7/16	2 15/16	1/4 x 1 5/8	1.52
4	9/16	3 3/16	1/4 x 1 5/8	1.76
5	9/16	3 3/4	1/4 x 1 5/8	1.98
6	9/16	4 1/4	1/4 x 1 5/8	2.25
8	9/16	5 5/16	1/4 x 1 3/4	3.10
10	9/16	6 5/16	1/4 x 1 3/4	3.70
12	9/16	7 5/16	1/4 x 1 3/4	4.40
14	15/16	8 7/8	3/8 x 1 3/4	7.80
16	15/16	9 7/8	3/8 x 1 3/4	8.70
18	15/16	11 3/4	1/2 x 1 3/4	13.20
20	15/16	12 3/4	1/2 x 1 3/4	14.50
24	15/16	14 3/4	1/2 x 1 3/4	17

QWI 4.3.1 Issue Date Mar/17 Rev.0

*Note: If details and dimensions are critical to your application please insure you are referencing the most recent version of this specification sheet from our website.*

**VAN HANGER**  
**Epoxy Coated Copper-Gard #129**

- 1/2" through 2"
- Carbon Steel
- Epoxy Coated Copper-Gard c/w Yellow Zinc Dichromate Screw
- Designed to support copper tubing to wall. Supports the pipe 1" from the back of pipe to wall. The wood screw is concealed upon installation.
- Specify tube size, figure number and name.

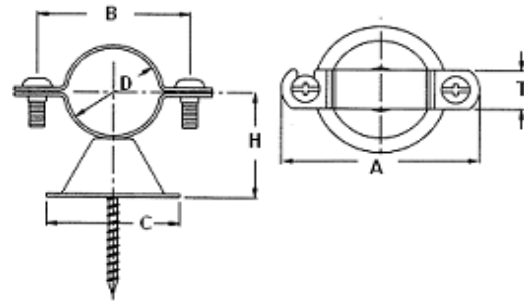

TUBE SIZE	D TUBE O.D.	SPECIFICATION DATA					APP'X WT. PER 100 (LBS)	PKG. QTY
		A	B	C	H	T		
1/2	0.625	2 3/16	1 9/16	1 5/8	1 1/16	1/2	6	25
3/4	0.875	2 3/8	1 3/4	1 5/8	1 3/16	1/2	6	25
1	1.125	2 7/16	1 7/8	1 5/8	1 5/16	1/2	6	25
1 1/4	1.375	2 11/16	2 1/8	1 5/8	1 7/16	1/2	8	25
1 1/2	1.625	3 1/16	2 7/16	1 5/8	1 9/16	1/2	8	25
2	2.125	4 7/16	2 13/16	1 5/8	1 13/16	1/2	9	25

**ASSEMBLED WITH #6 X 2 COARSE THREAD DRYWALL SCREW**



QWI 4.3.1 Issue Date Aug/16 Rev.1

*Note: when referencing a printed copy of this specification page please insure it is the latest version as found on our website at [www.taylorassociates.com](http://www.taylorassociates.com)*

## 2-BOLT PIPE CLAMP #31Z

- 1/2" through 36"
- Carbon Steel
- Electro-Plated Zinc
- Complies with MSS SP-58 and SP-69 (Type 4).
- Recommended for the suspension of non-insulated, pipe lines.
- Specify pipe size, figure number, name and finish.
- Also available in Bare, Hot Dipped Galvanized, and Stainless Steel

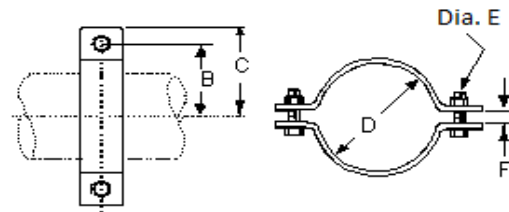

### Installation Note:

The B and C dimensions shown are approximate. When using a riser clamp in any application other than what it is designed for (i.e., supporting a riser pipe between floors of a building) confirm against the product in hand the hole centers and overall length if they are critical to your installation.

IRON PIPE SIZE	SPECIFICATION DATA					MATERIAL	REC. MAX LOAD	WT. PER. 100 (LBS.)	PCS. PER PKG
	B	C	D	E	F				
1/2	1 1/8	1 11/16	0.840	5/16	7/16	11Ga x 1	500	27	50
3/4	1 1/4	1 13/16	1.050	5/16	7/16	11Ga x 1	500	30	50
1	1 7/16	2	1.315	5/16	7/16	11Ga x 1	500	33	50
1 1/4	1 9/16	2 1/8	1.660	5/16	7/16	11Ga x 1	500	36	50
1 1/2	1 11/16	2 1/4	1.900	5/16	1/2	11Ga x 1	800	37	50
2	2 5/16	3 3/16	2.375	1/2	1/2	3Ga x 1	1040	104	25
2 1/2	2 5/8	3 1/2	2.875	1/2	3/4	3Ga x 1	1040	119	25
3	2 7/8	3 3/4	3.500	1/2	3/4	3Ga x 1	1040	127	25
3 1/2	3 1/8	4	4.000	1/2	3/4	3Ga x 1	1040	143	25
4	3 5/8	4 1/2	4.500	5/8	3/4	4Ga x 1 1/4	1040	194	25
5	4 1/8	5	5.563	5/8	3/4	4Ga x 1 1/4	1040	220	10
6	5	5 7/8	6.625	3/4	7/8	3/8 X 1 1/2	1615	542	BULK
8	6 1/8	7	8.625	3/4	1	3/8 X 1 1/2	1615	651	BULK
10	7 7/16	8 9/16	10.750	7/8	1	1/2 X 2	2490	1360	BULK
12	8 7/16	9 9/16	12.750	7/8	1	1/2 X 2	2490	1605	BULK
14	9 1/4	10 5/8	14.000	7/8	1 1/8	1/2 X 2 1/2	2490	2000	BULK
16	10 1/4	11 7/16	16.000	7/8	1 1/8	1/2 X 2 1/2	2490	2200	BULK
18	11 5/8	13	18.000	1	1 1/4	5/8 X 2 1/2	3060	3200	BULK
20	12 3/4	14 1/8	20.000	1 1/8	1 3/8	5/8 X 2 1/2	3060	3600	BULK
24	15 1/4	16 7/8	24.000	1 1/4	1 5/8	5/8 X 3	3060	5000	BULK
30	19	21 1/8	30.000	1 3/4	2	3/4 X 4	3500	11390	BULK
36	23	25 1/2	36.000	2	2 1/2	1 X 5	4000	21900	BULK



QWI 4.3.1 Issue Date Mar/16 Rev.11

*Note: when referencing a printed copy of this specification page please insure it is the latest version as found on our website at [www.taylorassociates.com](http://www.taylorassociates.com)*

# #31H 2-Bolt Pipe Clamp Heavy

**Finishes:** Bare Metal, Zinc Plated, Hot Dipped Galvanized

**Materials:** Carbon Steel, Stainless Steel 304SS & 316SS

**Approvals:** Complies with MSS SP-58 and SP-69 (Type 4).

**Recommended:** Recommended for suspension of heavy loads where little or no insulation is required.

Maximum temperatures: Bare Metal 750°F, Galvanized 450°F

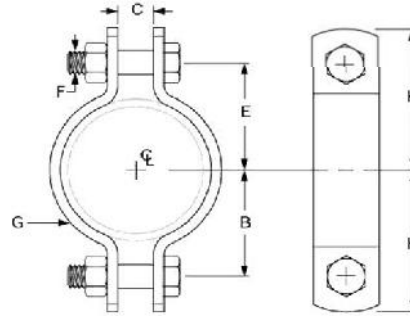

IRON PIPE SIZE	SPECIFICATION DATA						REC. MAX. LOAD		APP'X LBS. EACH
	B	C	Rod Take Out E	F	G	H	650° F	750° F	
3	3 1/8	1	3 1/8	3/4	3/8 x 2	4	3300	3005	2.7
4	3 3/4	1	3 3/4	7/8	3/8 x 2	4 7/8	3515	3135	5.9
5	4 3/8	1	4 3/8	7/8	3/8 x 2	5 1/2	3515	3135	6.6
6	5 1/4	1 1/8	5 1/4	1	1/2 x 2 1/2	6 5/8	4865	4340	12.4
8	6 1/4	1 1/8	6 1/4	1	1/2 x 2 1/2	7 5/8	4865	4340	14.7
10	7 15/16	1 1/4	7 15/16	1 1/4	5/8 x 2 1/2	9 5/16	6010	5360	24
12	9 1/2	1 5/8	9 1/2	1 1/2	3/4 x 3	11 1/8	8675	7740	41
14	10 1/4	1 5/8	10 1/4	1 1/2	3/4 x 4	12 1/8	9120	8135	55
16	11 1/4	1 5/8	11 1/4	1 1/2	3/4 x 4	13 1/8	9120	8135	59
18	14 1/4	3	14 1/4	2	3/4 x 6	17	13800	--	120
20	16	3	16	2	1 x 5	18 3/4	15300	--	164
24	18 1/2	3 1/4	18 1/2	2 1/4	1 x 6	21 1/2	16300	--	215
28	20 1/2	3 1/4	20 1/2	2 1/4	1 x 8	23 1/2	18000	--	303
30	22 1/2	3 1/2	22 1/2	2 1/2	1 1/4 x 7	26	20500	--	365
32	23 1/2	3 1/2	23 1/2	2 1/2	1 1/4 x 8	27	23750	--	432
34	25	3 1/2	25	2 1/2	1 1/2 x 8	28 1/2	25000	--	534
36	26 1/2	3 1/2	26 1/2	2 3/4	1 1/2 x 8	30 1/4	28000	--	575
42	30	3 1/2	30	2 3/4	1 3/4 x 10	33 3/4	35000	--	916



QWI 4.3.1 Issue Date Apr/18 Rev.5

Note: when referencing a printed copy of this specification page, please insure it is the latest version as found on our website at [www.taylorassociates.com](http://www.taylorassociates.com)

For more information, please contact Customer Service at 1-800-263-8652



3-BOLT PIPE CLAMP #33M

1/2" through 36"  
 Carbon Steel  
 Bare Metal  
 Complies with MSS SP-58 and SP-69 (Type 3).  
 For the suspension of insulated pipe lines normally used with weldless eye nut Fig. 64  
 Specify pipe size, figure number, name and finish.  
 Also available in Electro-Plated Zinc, Stainless Steel, and Hot Dipped Galvanized

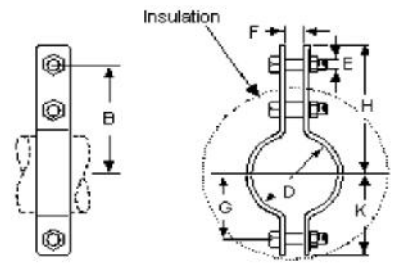

IRON PIPE SIZE	SPECIFICATION DATA								RECOM. MAX. LOAD LBS.	APP'X WT. PER.100 (LBS)
	B	D	E	F	G	H	K	MATERIAL	650 F	
1/2"	2 5/16	0.840	3/8	5/8	1	2 7/8	1 9/16	8Ga x 1	950	54
3/4"	2 7/16	1.050	3/8	5/8	1 1/16	3	1 5/8	8Ga x 1	950	57
1"	2 5/8	1.315	3/8	5/8	1 3/8	3 3/16	1 15/16	8Ga x 1	950	61
1 1/4"	2 15/16	1.660	3/8	5/8	1 1/2	3 1/2	2 1/16	8Ga x 1	950	68
1 1/2"	3 13/16	1.900	5/8	7/8	1 15/16	4 11/16	2 13/16	4Ga x 1 1/4	1545	172
2"	4 11/16	2.375	5/8	7/8	2 3/16	5 9/16	3 1/16	4Ga x 1 1/4	1545	193
2 1/2"	5 9/16	2.875	5/8	7/8	2 7/16	6 7/16	3 5/16	4Ga x 1 1/4	1545	212
3"	6 1/8	3.500	5/8	7/8	2 3/4	7	3 5/8	4Ga x 1 1/4	1545	226
3 1/2"	6 3/8	4.000	5/8	7/8	2 7/8	7 1/4	3 3/4	4Ga x 1 1/4	1545	237
4"	6 1/2	4.500	3/4	1 1/16	3 1/2	7 5/8	4 1/2	3/8 x 2	2500	750
5"	7	5.563	3/4	1 1/16	4	8 1/8	5	3/8 x 2	2500	813
6"	8 9/16	6.625	1	1 7/16	5	9 15/16	6 1/8	3/8 x 2 1/2	2865	1311
8"	9 9/16	8.625	1	1 7/16	6	10 15/16	7 1/8	3/8 x 2 1/2	2865	1467
10"	10 5/8	10.750	1	1 7/16	7 1/2	12	8 7/8	1/2 x 2 1/2	3240	2167
12"	11 5/8	12.750	1	1 7/16	8 1/2	13	9 7/8	1/2 x 2 1/2	3240	2383
14"	12 11/16	14.000	1 1/4	2	9 3/8	14 5/16	10 7/8	5/8 x 3	4300	3750
16"	13 11/16	16.000	1 1/4	2	10 3/8	15 5/16	12	5/8 x 3	4300	4100
18"	14 11/16	18.000	1 1/4	2	11 3/8	16 5/16	13	5/8 x 3	4300	4646
20"	15 7/8	20.000	1 1/2	2	12 3/4	17 1/2	14 3/8	3/4 x 3	5490	6000
24"	17 7/8	24.000	1 1/2	2	15	19 1/2	16 3/8	3/4 x 3	4500	7043
30"	23 3/8	30.000	1 1/2	2 1/2	18 1/2	26 1/8	21 1/4	3/4 x 5	7500	15000
36"	28 3/4	36.000	1 3/4	3	22 1/2	32 1/4	26	1 x 5	10500	25750



QWI 4.3.1 Issue Date Mar/16 Rev.6

*Note: when referencing a printed copy of this specification page please insure it is the latest version as found on our website at [www.taylorassociates.com](http://www.taylorassociates.com)*

### ALLOY 3-BOLT PIPE CLAMP #33A

- 1 1/2" through 24"
- Chrome Molybdenum Steel (ASTM A 387 Grade 22)
- Complies with MSS SP-58 and SP-69 (Type 3).
- Recommended for suspension of high temperature pipe requiring insulation.
- Maximum Temperature: 1,050°F
- Specify pipe size, figure number, name and finish.
- Note:** Galvanizing is not recommended for alloy products.

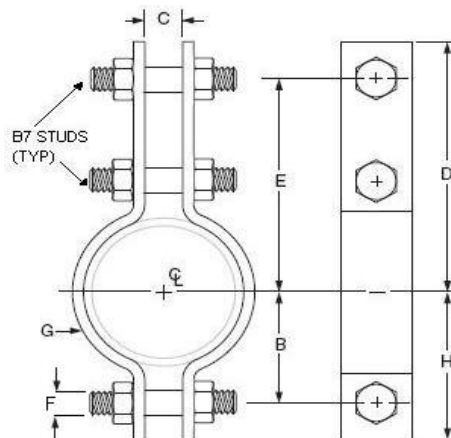

IRON PIPE SIZE	SPECIFICATION DATA							REC. MAX. LOAD (lbs) FOR SERVICE TEMP.				APP'X WT. LBS. EACH
	B	C	D	E	F	G	H	650° F	750° F	1000° F	1050° F	
1 1/2	1 13/16	1 1/16	4 7/8	4 1/8	5/8	1/4 x 1 1/4	2 3/8	1545	1410	1000	745	2.3
2	2 1/8	1 1/16	5 7/8	5 1/8	5/8	1/4 x 1 1/4	2 11/16	1545	1410	1000	745	2.6
2 1/2	2 5/16	1 1/16	6 1/8	5 3/8	5/8	1/4 x 1 1/4	2 15/16	1545	1410	1000	745	2.7
3	2 3/4	1 1/16	6 11/16	5 15/16	5/8	1/4 x 1 1/4	3 1/2	1545	1410	1000	745	3.0
4	3 3/8	1 1/16	7 5/8	6 1/2	3/4	3/8 x 2	4 1/2	2500	2290	1625	1200	6.7
5	3 15/16	1 1/16	8 1/8	7	3/4	3/8 x 2	5	2500	2290	1625	1200	7.0
6	4 3/4	1 7/16	9 15/16	8 9/16	7/8	3/8 x 2 1/2	6 1/8	2865	2620	1860	1380	11.5
8	5 3/4	1 7/16	10 15/16	9 9/16	7/8	3/8 x 2 1/2	7 1/8	2865	2620	1860	1380	13.2
10	7 1/16	1 7/16	12	10 5/8	1	1/2 x 2 1/2	8 1/4	3240	2970	2100	1565	19.8
12	8 1/16	1 7/16	12 15/16	11 5/8	1	1/2 x 2 1/2	9 5/16	3240	2970	2095	1565	22.3
14	9 1/16	2	14 5/16	12 11/16	1 1/4	5/8 x 3	10 11/16	4300	3915	2795	2060	37.7
16	10 1/16	2	15 5/16	13 11/16	1 1/4	5/8 x 3	11 11/16	4300	3915	2795	2060	41.4
18	11 1/16	2	16 5/16	14 11/16	1 1/4	5/8 x 3	12 11/16	4300	3915	2780	2060	44.9
20	12 3/8	2	17 1/2	15 7/8	1 3/8	3/4 x 3	14	5490	4995	3550	2635	57.3
24	14 3/8	2	19 1/2	17 7/8	1 3/8	3/4 x 3	16	4500	4095	2910	2160	65.9



QWI 4.3.1 Issue Date Apr/13 Rev.0

*Note: when referencing a printed copy of this specification page please insure it is the latest version as found on our website at [www.taylorassociates.com](http://www.taylorassociates.com)*

## UNDERGROUND BELL CLAMP #35

- 3" through 24"
- Carbon Steel Clamp, Cast Iron Washer
- Bare Metal
- Recommended as a safety device to be use on underground AWWA ductile iron pipe. This added reinforcement is necessary in any case of reversal, stoppage, or change in direction of flow.
- Specify pipe size, figure number, name and finish.
- Also available in Electro-Plated Zinc

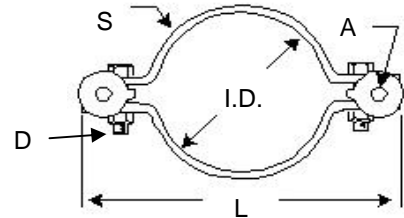

IRON PIPE SIZE	SPECIFICATION DATA					APP'X WT. PER 100 (LBS.)	
	I. D.	ROD DIA. A	BOLT DIA. D	L	MATERIAL S	WASHER	CLAMP
3	3.96"	3/4	5/8	12	3/8 x 2	130	598
4	4.80"	3/4	5/8	12 3/4	1/2 x 2	130	800
6	6.90"	3/4	5/8	15 1/2	1/2 x 2	130	995
8	9.05"	3/4	5/8	17 1/2	1/2 x 2	130	1210
10	11.10"	3/4	5/8	19 1/2	1/2 x 2	130	1363
12	13.20"	3/4	5/8	22	1/2 x 2	130	1565
14	15.30"	1	7/8	28 1/2	3/4 x 3	230	4180
16	17.40"	1 1/8	1	30 3/4	3/4 x 4	290	6193
18	19.50"	1 1/4	1 1/4	34 5/8	3/4 x 4	465	6515
20	21.60"	1 3/8	1 1/4	37 1/2	3/4 x 5	465	9225
24	25.80"	1 1/2	1 1/2	43	3/4 x 5	700	12274



QWI 4.3.1 Issue Date Mar/12 Rev.6

*Note: when referencing a printed copy of this specification page please insure it is the latest version as found on our website at [www.taylorassociates.com](http://www.taylorassociates.com)*

# #33H 3-Bolt Pipe Clamp Heavy

**Finishes:** Bare Metal, Zinc Plated, Hot Dipped Galvanized

**Materials:** Carbon Steel, Stainless Steel 304SS & 316SS

**Approvals:** Complies with MSS SP-58 and SP-69 (Type 3).

**Recommended:** Recommended for supporting pipe up to 4" of insulation.

Maximum temperatures: Bare Metal 750°F, Galvanized 450°F

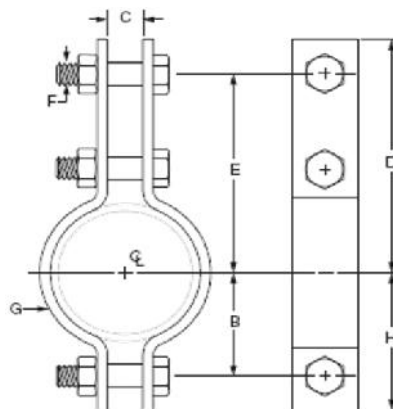

IRON PIPE SIZE	SPECIFICATION DATA							RECOM. MAX. LOAD (LBS)		APP'X WT. EACH (LBS)
	B	C	D	E	F	G	H	650 F	750 F	
4	4 1/2	1 3/4	9	7 3/4	7/8	3/8 x 2 1/2	5 3/4	3500	3215	12
6	4 3/4	1 3/4	10 3/16	8 15/16	1	3/8 x 2 1/2	6	3500	3125	12
8	6	2	11 3/8	10 1/8	1 1/8	1/2 x 2 1/2	7 1/4	4800	4285	19
10	7 1/2	2 1/4	13 1/8	11 3/8	1 1/4	1/2 x 4	9	5500	4910	34
12	9	2 1/2	14 9/16	12 13/16	1 1/2	5/8 x 4	10 5/8	7000	6250	42
14	9 7/8	2 1/2	15 3/4	13 3/4	1 1/2	3/4 x 4	11 7/8	9500	8485	60
16	11 1/8	3	17 3/8	15 1/8	1 3/4	3/4 x 5	13 3/8	10000	8930	80
18	13	3 1/2	19 1/2	17 1/2	2	1 x 4	15 1/4	13800	12325	115
20	14 1/4	3 1/2	21	18 1/2	2	1 x 5	17	15300	13665	140
24	16	3 1/2	23 1/4	20 1/4	2	1 x 6	18 3/4	16300	14555	190
30	19 7/8	4 1/4	32 3/4	28 1/4	2 1/4	1 x 8	24 3/8	20500	--	406
36	24 5/8	4 1/2	40 1/4	34 3/4	2 3/4	1 1/2 x 8	30 1/8	28000	--	678



QWI 4.3.1 Issue Date Apr/18 Rev.4

Note: when referencing a printed copy of this specification page, please insure it is the latest version as found on our website at [www.taylorassociates.com](http://www.taylorassociates.com)

For more information, please contact Customer Service at 1-800-263-8652

### HINGED SPLIT RING HANGER #38R

- 3/8" through 4"
- Malleable Iron
- Electro-Plated Zinc
- Complies with MSS SP-58 and SP-69 (Type 12).
- Recommended for the suspension of non-insulated stationary pipe.
- Specify pipe size, figure number, name and finish.

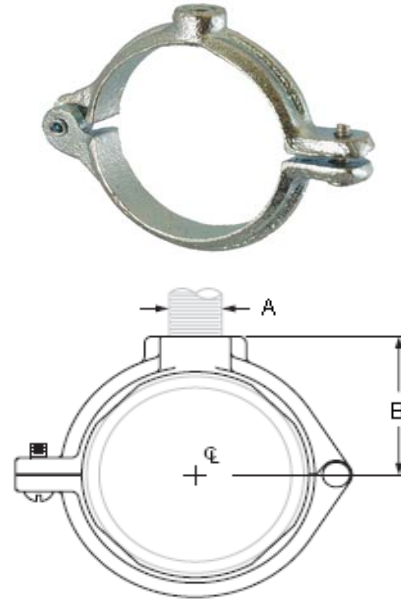

IRON PIPE SIZE	SPECIFICATION DATA		REC. MAX. LOAD (LBS)	APP'X WT. PER 100 (LBS)	PC'S PER PKG.
	ROD SIZE A	B			
3/8	3/8	13/16	180	9	100
1/2	3/8	7/8	180	9	100
3/4	3/8	1	180	11	100
1	3/8	1 1/8	180	14	100
1 1/4	3/8	1 5/16	180	18	50
1 1/2	3/8	1 7/16	180	22	50
2	3/8	1 11/16	180	26	50
2 1/2	1/2	2 1/8	300	44	25
3	1/2	2 7/16	300	51	25
4	1/2	2 3/4	300	71	25



QWI 4.3.1 Issue Date Mar/16 Rev.5

*Note: when referencing a printed copy of this specification page please insure it is the latest version as found on our website at [www.taylorassociates.com](http://www.taylorassociates.com)*

### SPLIT RING HANGER #38R SS

- 3/8" through 4"
- 304 (SS4) and 316 (SS6) Stainless Steel
- Complies with MSS SP-58 and SP-69 (Type 12).
- Recommended for the suspension of non-insulated stationary pipe and where protection from corrosive environment is required.
- Specify pipe size, figure number, name and type.

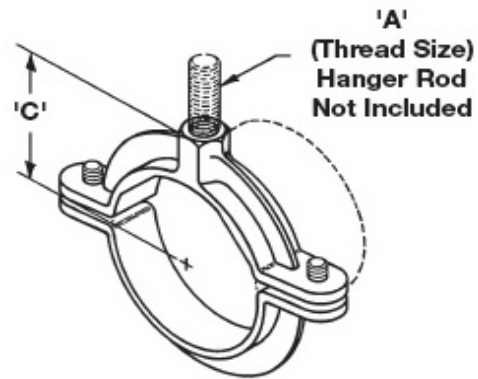

PIPE IRON	SPECIFICATION DATA		REC. MAX. LOAD (LBS)	APP'X WT. PER 100 (LBS)	PC'S PER PKG.
	ROD SIZE A	C			
3/8	3/8	11/16	180	9	100
1/2	3/8	3/4	180	9	100
3/4	3/8	7/8	180	11	100
1	3/8	1 1/8	180	14	100
1 1/4	3/8	1 5/16	180	18	50
1 1/2	3/8	1 7/16	180	22	50
2	3/8	1 5/8	180	26	50
2 1/2	1/2	2 1/8	300	44	25
3	1/2	2 1/2	300	51	25
4	1/2	2 7/8	300	71	25



QWI 4.3.1 Issue Date Mar/16 Rev.1

*Note: when referencing a printed copy of this specification page please insure it is the latest version as found on our website at [www.taylorassociates.com](http://www.taylorassociates.com)*

### HINGED SPLIT RING HANGER Epoxy Coated Copper-Gard #38C

- 3/4" through 4"
- Malleable Iron
- Epoxy Coated Copper-Gard c/w Zinc Hardware
- Complies with MSS SP-58 and MSS SP-69 (Type 12).
- Recommended for the suspension of non-insulated stationary copper tubing.
- Specify pipe size, figure number, name and finish.

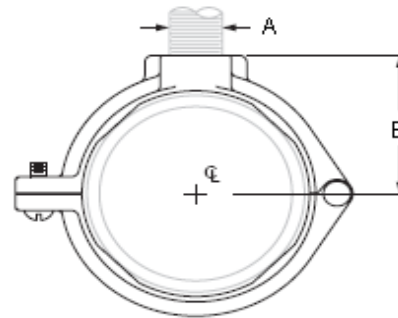

COPPER TUBE SIZE	SPECIFICATION DATA		REC. MAX LOAD (LBS)	APP'X WT. PER 100 (LBS)	PC'S PER PKG.
	ROD SIZE A	B			
3/8	3/8	13/16	180	10	100
1/2	3/8	13/16	180	10	100
3/4	3/8	7/8	180	13	100
1	3/8	1	180	14	100
1 1/4	3/8	1 1/8	180	16	100
1 1/2	3/8	1 5/16	180	22	50
2	3/8	1 11/16	180	31	50
2 1/2	1/2	2 1/8	300	60	50
3	1/2	2 7/16	300	74	50
4	1/2	2 3/4	300	85	25



QWI 4.3.1 Issue Date Aug/16 Rev.5

*Note: when referencing a printed copy of this specification page please insure it is the latest version as found on our website at [www.taylorassociates.com](http://www.taylorassociates.com)*



# BISMAT® 5000 Rubber Lined Clamp

**Finishes:** Zinc Plated, Rubber Lined

**Materials:** Carbon Steel / EPDM Rubber

**Approvals:** Complies with MSS SP-58 & SP-69 (Type 12).

**Recommended:** for use with PEX, CPVC and PVC pipe

**Notes:** Green rubber lining formulated without plasticizers  
 Easy open/close locking system  
 Inner lining is smooth to allow for expansion and contraction  
 Patented spacer washers allow for sliding or fixed hanger positions  
 Temperature rating -40°F to 200°F  
 ASTM E-84 plenum rated  
 Easy-Close mechanism in this versatile EPDM rubber lined clamp. Saves installation time and effort, prevents vibration, noise, and metal to metal contact.



15mm to 60-65mm



63mm and above

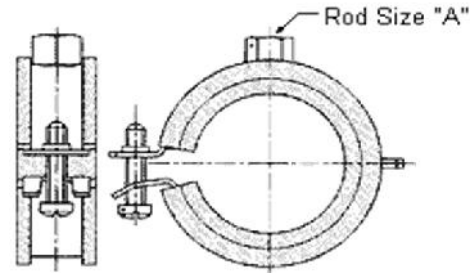

Metric (mm)	IP Size	Copper Tube Size	Rod Size " A "	F <sub>a,z</sub> (lbs)	Box Qty	LBS/c
15-18	3/8	1/2	3/8	180	50	4.6
20-23	1/2	3/4	3/8	180	50	5.5
25-28	3/4	1	3/8	180	50	5.9
31-35	1	1 1/4	3/8	180	50	7.0
40-43	1 1/4	1 1/2	3/8	180	50	9.0
48-53	1 1/2	--	3/8	180	50	9.9
54-56	--	2	3/8	180	50	14.0
60-65	2	--	3/8	180	50	14.2
63	--	--	3/8	180	50	14.7
70-76	2 1/2	--	3/8	300	50	16.3
86-91	3	--	3/8	300	25	18.0
110-114	4*	--	3/8	300	25	24.4
124-132	*	--	1/2	500	25	30.0
155-160	*	--	1/2	500	10	36.0

\* Note: Sizes vary between PVC and Metric pipes.



QWI 4.3.1 Issue Date Sept/18 Rev.7

Note: when referencing a printed copy of this specification page, please insure it is the latest version as found on our website at [www.taylorassociates.com](http://www.taylorassociates.com)

For more information, please contact Customer Service at 1-800-263-8652

## #40 SPLIT RING HANGER

**Finish:** Zinc Plated, Rubber Lined

**Material:** Carbon Steel / EPDM Rubber



**Approvals:** MSS SP-58 (Type 12)

**Recommended:** for the suspension of insulated and non-insulated pipe lines.

**Notes:** UV resistant rubber lining provides for noise reduction and vibration control.  
Temperature range use -20F to +230F  
Swing gate style clamp for quick and easy installation (no loose hardware).

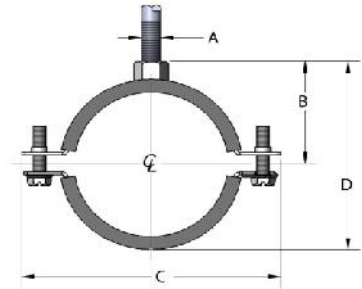

Iron Pipe Size	Copper Tube Size	Metric Size (mm)	SPECIFICATION DATA				LBS Each	Rec. Max Load (Lbs)
			A	B	C	D		
1/4	3/8	11-14	3/8 - 16	7/8	2 3/16	1 3/8	.11	180
3/8	1/2	15-18	3/8 - 16	15/16	2 3/8	1 1/2	.12	180
-	5/8	19	3/8 - 16	1	2 3/8	1 5/8	.12	180
1/2	3/4	20-23	3/8 - 16	1 1/16	2 9/16	1 3/4	.14	180
3/4	1	25-29	3/8 - 16	1 3/16	2 3/4	2	.15	180
1	1 1/4	30-35	3/8 - 16	1 1/4	3 1/8	2 1/4	.17	180
1 1/4	1 1/2	40-45	3/8 - 16	1 7/16	3 1/2	2 1/2	.19	180
1 1/2	-	46-51	3/8 - 16	1 9/16	3 3/4	2 3/4	.2	180
-	2	53-59	3/8 - 16	1 11/16	3 15/16	3	.26	180
2	-	59-64	3/8 - 16	1 3/4	4 1/8	3 1/4	.27	180
-	2 1/2	67-71	3/8 - 16	1 15/16	4 7/16	3 1/2	.29	300
2 1/2	-	72-78	3/8 - 16	2 1/16	4 3/4	3 3/4	.36	300
-	3	80-84	3/8 - 16	2 1/4	5	4 1/16	.38	300
3	-	86-92	3/8 - 16	2 7/16	5 7/16	4 7/16	.41	300
-	3 1/2	95-99	3/8 - 16	2 1/2	5 9/16	4 9/16	.41	300
3 1/2	4	100-107	3/8 - 16	2 3/4	6 1/8	5 1/16	.67	300
4	-	108-116	3/8 - 16	2 15/16	6 7/16	5 7/16	.70	300

QWI 4.3.1 Issue Date July 2017 Rev.0

*Note: If details and dimensions are critical to your application please insure you are referencing the most recent version of this specification sheet from our website.*

## MANHOLE DROP PIPE CLAMP

**FIG#47** - For SDR 35 Pipe

**FIG#48** - For DIP(C-900) Pipe

**FIG#49** - For IPS Schedule 40 Pipe

- 4" through 12"
- Stainless Steel Type 304
- Designed for easy installation and support of manhole drop pipe.
- Specify size, figure number, and name.

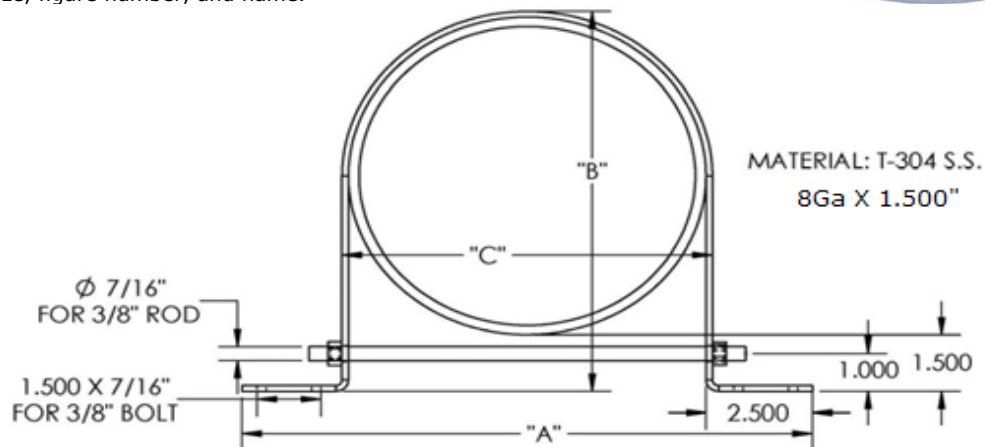

**Figure #47 - For SDR-35 PIPE**

SIZE	SDR-35 PIPE OD	ROD LENGTH	"A"	"B"	"C"
4"	4.215"	5 7/8"	9.215"	5.865"	4.514"
6"	6.275"	7 5/8"	11.275"	7.925"	6.574"
8"	8.400"	10 1/4"	13.400"	10.050"	8.700"
10"	10.500"	12 1/4"	15.500"	12.150"	10.800"
12"	12.500"	14 1/4"	17.500"	14.150"	12.800"

**Figure #48 - For DIP (C-900) PIPE**

SIZE	DIP C-900 OD	ROD LENGTH	"A"	"B"	"C"
4"	4.800"	6 1/2"	9.800"	6.450"	5.100"
6"	6.900"	8 3/4"	11.900"	8.550"	7.200"
8"	9.050"	10 7/8"	14.050"	10.700"	9.350"
10"	11.100"	12 7/8"	16.100"	12.750"	11.400"
12"	13.200"	15"	18.200"	14.850"	13.500"

**Figure #49 - For IPS Schedule 40 PIPE**

SIZE	IPS OD	ROD LENGTH	"A"	"B"	"C"
4"	4.500"	6 3/8"	9.500"	6.150"	4.800"
6"	6.625"	8"	11.625"	8.275"	6.924"
8"	8.625"	10 1/2"	13.625"	10.275"	8.924"
10"	10.750"	12 1/2"	15.750"	12.400"	11.050"
12"	12.750"	14 1/2"	17.750"	14.400"	13.050"



QWI 4.3.1 Issue Date Oct/16 Rev.1

*Note: when referencing a printed copy of this specification page please insure it is the latest version as found on our website at [www.taylorassociates.com](http://www.taylorassociates.com)*

**starQuick® SELF-LOCKING PIPE CLAMP**

1/4" - 2" Copper Tube and Iron Pipe

UV-stabilized Polymer

Bare Metal

Time and cost saving solution for pipe fixing  
due to self-locking attribute.

ASTM E-84 - plenum rated, UL Listed

Temperature resistance -40°F to 200°F

Specify part number, pipe size, and name.



PART No.	SPECIFICATION DATA			PC'S. PER PKG.
	Diameter (mm)	IP (")	CT (")	
SQ-10	10 - 12	-	1/4	100
SQ-12	12 - 14	1/4	3/8	100
SQ-15	14 - 16	-	1/2	100
SQ-17	16 - 20	3/8	5/8 PEX	100
SQ-20	20 - 23	1/2	3/4	50
SQ-25	24 - 28	3/4	-	50
SQ-28	28 - 32	-	1	50
SQ-32	32 - 35	1	1 1/4	50
SQ-36	35 - 40	-	-	25
SQ-40	40 - 44	1 1/4	1 1/2	25
SQ-47	44 - 50	1 1/2	-	25
SQ-51	48 - 55	-	2	15
SQ-59	59 - 65	2	-	15

Scroll down for load ratings, expanded sizing charts, and other technical information



QWI 4.3.1 Issue Date Jan/12 Rev.2

*Note: when referencing a printed copy of this specification page please insure it is the latest version as found on our website at [www.taylorassociates.com](http://www.taylorassociates.com)*

**Product Specification**

**starQuick® System**

**25/50 Plenum Rated**

**starQuick® Clamp + starQuick® Universal Rail Adaptor**

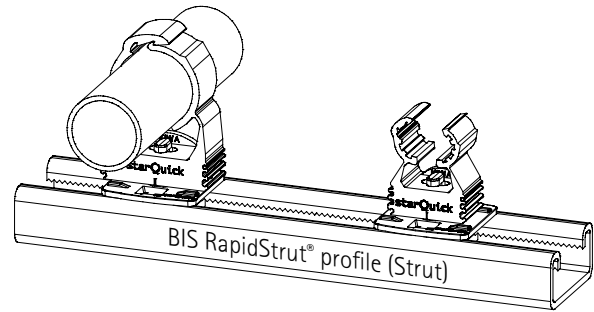
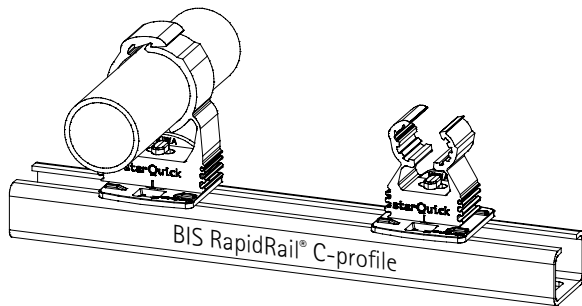

**Specification:**

The starQuick® System is a flame and smoke rated clamp compatible for use with Copper, Iron Pipe, PEX, CPVC, PVC, Conduit, Wire, Cable and more. Supports 1/4" CTS up to 2" IPS tubing sizes. When paired with the Universal Rail Adaptor, starQuick® Clamps mount easily to Strut or BIS RapidRail® C-profile. Material meets ASTM E-84 25/50 Flame/Smoke rating.

**Product Information:**

- Material: PA-6 Nylon - Grey
- Temperature range: -40° F to 200° F (constant), 260° F (peak)
- Load rating: see Chart
- Meets ASTM E-84 25/50 plenum rating
- UV Stabilized
- UL, UPC / IAPMO listed

**starQuick® Clamp (085 4 0XX)**

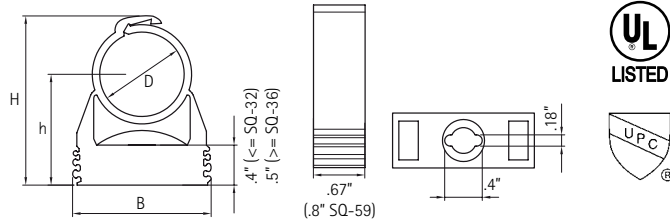

**starQuick® Universal Rail Adaptor (085 4 332)**

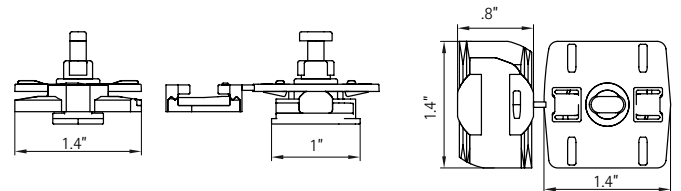

Part No.	Type	D (mm)	IP (")	CT (")	B (")	H (")	D (")	Fa,z (lbs)	Fb,z (lbs)
085 4 010	SQ-10	10 - 12	-	1/4	1.1	1.3	0.91	38	112
085 4 012	SQ-12	12 - 14	1/4	3/8	1.1	1.3	0.91	40	123
085 4 015	SQ-15	14 - 16	-	1/2	1.1	1.4	0.94	45	134
085 4 018	SQ-17	16 - 20	3/8	5/8	1.1	1.6	1.00	51	157
085 4 022	SQ-20	20 - 23	1/2	3/4	1.1	1.7	1.10	60	179
085 4 028	SQ-25	24 - 28	3/4	-	1.6	2.0	1.20	63	191
085 4 031	SQ-28	28 - 32	-	1	1.6	2.1	1.30	67	202
085 4 035	SQ-32	32 - 35	1	1 1/4	1.7	2.2	1.30	74	224
085 4 038	SQ-36	35 - 40	-	-	1.9	2.6	1.60	83	247
085 4 042	SQ-40	40 - 44	1 1/4	1 1/2	2.0	2.8	1.70	90	269
085 4 050	SQ-47	44 - 50	-	-	2.2	3.0	1.80	96	292
085 4 054	SQ-51	48 - 55	1 1/2	2	2.5	3.2	1.90	105	314
085 4 063	SQ-59	59 - 65	2	-	2.9	3.7	2.20	112	337
085 4 332	Universal Rail Adaptor								

Fa = maximum allowed load, Fb = breaking load

**Product Submittal**

Job Name:	
Date:	
Part No.	Qty:
Architect / Owner:	
Contractor:	
Notes:	

## Selection Chart

## starQuick® System

Part No.	Type	D (mm)	IP (")	CT (")	B (")	H (")	D (")	Fa,z (lbs)	Fb,z (lbs)
085 4 010	SQ-10	10 - 12	-	1/4	1.1	1.3	0.91	38	112
085 4 012	SQ-12	12 - 14	1/4	3/8	1.1	1.3	0.91	40	123
085 4 015	SQ-15	14 - 16	-	1/2	1.1	1.4	0.94	45	134
085 4 018	SQ-17	16 - 20	3/8	5/8	1.1	1.6	1.00	51	157
085 4 022	SQ-20	20 - 23	1/2	3/4	1.1	1.7	1.10	60	179
085 4 028	SQ-25	24 - 28	3/4	-	1.6	2.0	1.20	63	191
085 4 031	SQ-28	28 - 32	-	1	1.6	2.1	1.30	67	202
085 4 035	SQ-32	32 - 35	1	1 1/4	1.7	2.2	1.30	74	224
085 4 038	SQ-36	35 - 40	-	-	1.9	2.6	1.60	83	247
085 4 042	SQ-40	40 - 44	1 1/4	1 1/2	2.0	2.8	1.70	90	269
085 4 050	SQ-47	44 - 50	-	-	2.2	3.0	1.80	96	292
085 4 054	SQ-51	48 - 55	1 1/2	2	2.5	3.2	1.90	105	314
085 4 063	SQ-59	59 - 65	2	-	2.9	3.7	2.20	112	337

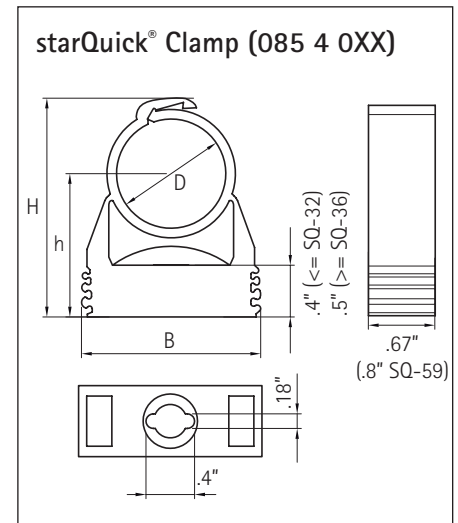

Fa = maximum allowed load, Fb = breaking load

Plastic Pipe	Nominal pipe size / actual pipe outside diameter								
	1/8" ID .405" OD	1/4" .540"	3/8" .675"	1/2" .840"	3/4" 1.050"	1" 1.315"	1.1/4" 1.660"	1.1/2" 1.900"	2" 2.375"
PVC Schedules 40, 80 & 120	085 4 010 sQ10	085 4 012 sQ12	085 4 018 sQ17	085 4 022 sQ20	085 4 028 sQ25	085 4 035 sQ32	085 4 042 sQ40	085 4 050 sQ47	085 4 063 sQ59
CPVC Schedules 40 & 80	-	085 4 012 sQ12	085 4 018 sQ17	085 4 022 sQ20	085 4 028 sQ25	085 4 035 sQ32	085 4 042 sQ40	085 4 050 sQ47	085 4 063 sQ59
ABS Schedules 40 & 80	-	-	085 4 018 sQ17	085 4 022 sQ20	085 4 028 sQ25	085 4 035 sQ32	085 4 042 sQ40	085 4 050 sQ47	085 4 063 sQ59
PE Schedules 40 & 80	-	085 4 012 sQ12	085 4 018 sQ17	085 4 022 sQ20	085 4 028 sQ25	085 4 035 sQ32	085 4 042 sQ40	085 4 050 sQ47	085 4 063 sQ59
PP Schedules 40 & 80	-	-	085 4 018 sQ17	085 4 022 sQ20	085 4 028 sQ25	085 4 035 sQ32	085 4 042 sQ40	085 4 050 sQ47	085 4 063 sQ59
PVDF Schedule 80	-	-	085 4 018 sQ17	085 4 022 sQ20	085 4 028 sQ25	085 4 035 sQ32	085 4 042 sQ40	085 4 050 sQ47	085 4 063 sQ59
PB Schedule 80	-	-	085 4 018 sQ17	085 4 022 sQ20	085 4 028 sQ25	085 4 035 sQ32	085 4 042 sQ40	085 4 050 sQ47	085 4 063 sQ59
Fiberglass Reinforced pipe standard + extra heavy	-	-	-	085 4 022 sQ20	085 4 028 sQ25	085 4 035 sQ32	-	085 4 050 sQ47	085 4 063 sQ59

085 4 OXX = Part No. / sQXX = Type

Metal Pipe	Nominal pipe size / actual pipe outside diameter								
	1/8" ID .405" OD	1/4" .540"	3/8" .675"	1/2" .840"	3/4" 1.050"	1" 1.315"	1.1/4" 1.660"	1.1/2" 1.900"	2" 2.375"
Galvanized Carbon Steel Schedules 5s, 10s, 40 & 80	085 4 010 sQ10	085 4 012 sQ12	085 4 018 sQ17	085 4 022 sQ20	085 4 028 sQ25	085 4 035 sQ32	085 4 042 sQ40	085 4 050 sQ47	085 4 063 sQ59
Stainless Steel Schedules 5s, 10s, 40 & 80	085 4 010 sQ10	085 4 012 sQ12	085 4 018 sQ17	085 4 022 sQ20	085 4 028 sQ25	085 4 035 sQ32	085 4 042 sQ40	085 4 050 sQ47	085 4 063 sQ59
Red & Yellow Brass & Copper Regular & Extra Strong	085 4 010 sQ10	085 4 012 sQ12	085 4 018 sQ17	085 4 022 sQ20	085 4 028 sQ25	085 4 035 sQ32	-	085 4 050 sQ47	085 4 063 sQ59
Aluminium 5s, 10s, 40 & 80	085 4 010 sQ10	085 4 012 sQ12	085 4 018 sQ17	085 4 022 sQ20	085 4 028 sQ25	085 4 035 sQ32	085 4 042 sQ40	085 4 050 sQ47	085 4 063 sQ59

085 4 0XX = Part No. / sQXX = Type

Copper Tube	Nominal tube size / actual tube outside diameter								
	1/4" .375"	3/8" .500"	1/2" .625"	5/8" .750"	3/4" .875"	1" 1.125"	1.1/4" 1.375"	1.1/2" 1.625"	2" 2.125"
ACR	085 4 010 sQ10	085 4 012 sQ12	085 4 015 sQ15	085 4 018 sQ17	085 4 022 sQ20	085 4 031 sQ28	085 4 035 sQ32	085 4 042 sQ40	085 4 054 sQ51
Refrigeration Service	085 4 010 sQ10	085 4 012 sQ12	085 4 015 sQ15	085 4 018 sQ17	085 4 022 sQ20	085 4 031 sQ28	085 4 035 sQ32	085 4 042 sQ40	085 4 054 sQ51
Type K, L, M	085 4 010 sQ10	085 4 012 sQ12	085 4 015 sQ15	085 4 018 sQ17	085 4 022 sQ20	085 4 031 sQ28	085 4 035 sQ32	085 4 042 sQ40	085 4 054 sQ51
DWV	-	-	-	-	-	-	085 4 035 sQ32	085 4 050 sQ47	085 4 054 sQ51

085 4 0XX = Part No. / sQXX = Type

Plastic Tube	Nominal tube size / actual tube outside diameter								
	1/4" .375"	3/8" .500"	1/2" .625"	3/4" .875"	1" 1.125"	1.1/4" 1.375"	1.1/2" 1.625"	2" 2.125"	
Polybutylene	085 4 010 sQ10	085 4 012 sQ12	085 4 015 sQ15	085 4 022 sQ20	085 4 031 sQ28	085 4 035 sQ32	085 4 042 sQ40	085 4 054 sQ51	
PVC	-	-	085 4 015 sQ15	085 4 022 sQ20	085 4 031 sQ28	085 4 035 sQ32	085 4 042 sQ40	085 4 054 sQ51	
PEX	085 4 010 sQ10	085 4 012 sQ12	085 4 015 sQ15	085 4 022 sQ20	085 4 031 sQ28	085 4 035 sQ32	085 4 042 sQ40	085 4 054 sQ51	
CPVC	-	085 4 012 sQ12	085 4 015 sQ15	085 4 022 sQ20	085 4 031 sQ28	085 4 035 sQ32	085 4 042 sQ40	085 4 054 sQ51	
DWV	-	-	085 4 015 sQ15	085 4 022 sQ20	085 4 031 sQ28	085 4 035 sQ32	085 4 042 sQ40	085 4 054 sQ51	

See manufacturers sales information for sizing information.

085 4 0XX = Part No. / sQXX = Type



Electrical Conduit Rigid	Nominal tube size / actual tube outside diameter					
	1/2"	3/4"	1"	1.1/4"	1.1/2"	2"
EMT (Galvanized Steel)	085 4 018 sQ17	085 4 022 sQ20	085 4 028 sQ25	085 4 042 sQ40	085 4 042 sQ40	-
IMC (Galvanized Steel & Aluminium)	085 4 022 sQ20	085 4 028 sQ25	085 4 035 sQ32	085 4 042 sQ40	085 4 050 sQ47	085 4 063 sQ59
Rigid (Galvanized Steel & Aluminium)	085 4 022 sQ20	085 4 028 sQ25	085 4 035 sQ32	085 4 042 sQ40	085 4 050 sQ47	085 4 063 sQ59
PVC Schedules 40 & 80	085 4 022 sQ20	085 4 028 sQ25	085 4 035 sQ32	085 4 042 sQ40	085 4 050 sQ47	085 4 063 sQ59
40 mm PVC Coated Rigid (Galvanized Steel & Alum.)	085 4 022 sQ20	085 4 031 sQ28	085 4 035 sQ32	085 4 050 sQ47	085 4 054 sQ51	085 4 063 sQ59
40 mm PVC Coated IMC (Galvanized Steel & Alum.)	085 4 022 sQ20	085 4 031 sQ28	085 4 035 sQ32	085 4 042 sQ40	085 4 054 sQ51	-
24 mm PVC Coated EMT (Galvanized Steel)	085 4 018 sQ17	085 4 028 sQ25	085 4 035 sQ32	085 4 042 sQ40	085 4 050 sQ47	-
Fiberglass (Small diameter tube dimensions)	-	-	-	-	-	085 4 054 sQ51
Fiberglass Standard & (Heavy wall pipe dimens.)	-	085 4 028 sQ25	085 4 035 sQ32	085 4 042 sQ40	085 4 054 sQ51	085 4 063 sQ59
Other speciality as Stainless Steel, Everdur same O.D. as IMC and Rigid	085 4 022 sQ20	085 4 028 sQ25	085 4 035 sQ32	085 4 042 sQ40	085 4 050 sQ47	085 4 063 sQ59

085 4 0XX = Part No. / sQXX = Type

Electrical Conduit Flexible	Nominal tube size / actual tube outside diameter								
	1/4"	5/16"	3/8"	1/2"	3/4"	1"	1.1/4"	1.1/2"	2"
Flexible Metal (Galvanized Steel & Aluminium)	-	085 4 012 sQ12	085 4 015 sQ15	085 4 022 sQ20	085 4 028 sQ25	085 4 035 sQ32	085 4 042 sQ40	085 4 050 sQ47	085 4 063 sQ59
Liquidtight Flexible (Metallic & Non-Metallic)	085 4 010 sQ10	085 4 015 sQ15	085 4 018 sQ17	085 4 022 sQ20	085 4 028 sQ25	085 4 035 sQ32	085 4 042 sQ40	085 4 050 sQ47	085 4 063 sQ59
Corrugated Flexible (Non- Metallic & Liquidtight)	-	-	085 4 018 sQ17	085 4 022 sQ20	085 4 028 sQ25	085 4 035 sQ32	085 4 042 sQ40	085 4 050 sQ47	085 4 063 sQ59
ENMT (Electric Non-Metallic)	-	-	-	085 4 022 sQ20	085 4 028 sQ25	085 4 035 sQ32	-	-	-
Corrlock® Flexible Nylon	-	-	085 4 015 sQ15	085 4 022 sQ20	085 4 035 sQ32	085 4 035 sQ32	085 4 042 sQ40	085 4 054 sQ51	-
Liquatite® (Non-Metallic Flexible (LNM & LNMP))	-	-	085 4 018 sQ17	085 4 022 sQ20	085 4 028 sQ25	085 4 035 sQ32	085 4 042 sQ40	085 4 050 sQ47	085 4 063 sQ59
Other speciality as Corrugated Ducts for Fiber Optics, same O.D. as Rigid	-	-	-	-	-	085 4 035 sQ32	085 4 042 sQ40	085 4 050 sQ47	085 4 063 sQ59

085 4 0XX = Part No. / sQXX = Type

Other Tube	Nominal tube size / actual tube outside diameter								
	1/8" .405	1/4" .54	3/8" .675	1/2" .84	3/4" 1.05	1" 1.315	1.1/4" 1.66	1.1/2" 1.9	2" 2.375
Galvanized Steel	085 4 010 sQ10	085 4 012 sQ12	085 4 018 sQ17	085 4 022 sQ20	085 4 028 sQ25	085 4 035 sQ32	085 4 042 sQ40	085 4 050 sQ47	085 4 063 sQ59
Stainless Steel	085 4 010 sQ10	085 4 012 sQ12	085 4 018 sQ17	085 4 022 sQ20	085 4 028 sQ25	085 4 035 sQ32	085 4 042 sQ40	085 4 050 sQ47	085 4 063 sQ59
Aluminium	085 4 010 sQ10	085 4 012 sQ12	085 4 018 sQ17	085 4 022 sQ20	085 4 028 sQ25	085 4 035 sQ32	085 4 042 sQ40	085 4 050 sQ47	085 4 063 sQ59

085 4 0XX = Part No. / sQXX = Type

Copper Wire	starQuick® & Grounding Conductors					
	Part No. Type	Bare Stranded Copper OD	Part No. Type	Thhn OD	Part No. Type	Thw OD
#3	-	-	-	-	085 4 010 sQ10	0.390"
#2	-	-	085 4 010 sQ10	0.390" - 0.400"	085 4 010 sQ10	0.420"
#1	-	-	085 4 010 sQ10	0.450" - 0.460"	085 4 012 sQ12	0.490" - 0.500"
#1/o	085 4 010 sQ10	0.373"	085 4 012 sQ12	0.490" - 0.500"	085 4 012 sQ12	0.530" - 0.540"
#2/o	085 4 010 sQ10	0.419"	085 4 012 sQ12	0.540" - 0.550"	085 4 015 sQ15	0.580" - 0.590"
#3/o	085 4 012 sQ12	0.470"	085 4 015 sQ15	0.590" - 0.600"	085 4 015 sQ15	0.630" - 0.640"
#4/o	085 4 012 sQ12	0.528"	085 4 018 sQ17	0.650" - 0.660"	085 4 018 sQ17	0.690" - 0.700"
250 MCM	085 4 015 sQ15	0.575"	085 4 018 sQ17	0.720" - 0.730"	085 4 018 sQ17	0.770" - 0.780"
350 MCM	085 4 018 sQ17	0.681"	085 4 022 sQ20	0.820" - 0.840"	085 4 022 sQ20	0.870" - 0.880"
400 MCM	085 4 018 sQ17	0.728"	085 4 022 sQ20	0.880"	085 4 022 sQ20	0.920" - 0.930"
500 MCM	085 4 022 sQ20	0.813"	085 4 028 sQ25	0.960" - 0.970"	085 4 028 sQ25	1.010" - 1.100"
750 MCM	085 4 028 sQ25	0.998"	085 4 031 sQ28	1.180"	085 4 031 sQ28	1.230"
1000 MCM	085 4 031 sQ28	1.152"	085 4 035 sQ32	1.330"	085 4 035 sQ32	1.380"

085 4 0XX = Part No. / sQXX = Type

# #82Z Riser Clamp

Finish: Bare Metal, Zinc Plated, HDG  
**for 304SS and 316SS**  
*see separate specification sheet*

Material: Carbon Steel  
 Bare Metal (#82)

Approvals: Complies with MSS SP-58 and SP-69 (Type 8).  
 cUL Approved (2" through 8")



Recommended: For the support and stabilizing of vertical pipe runs.

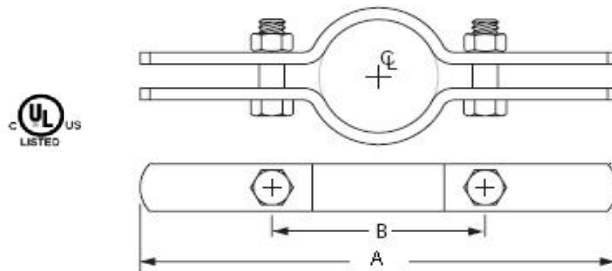

## Installation Note:

The A and B dimensions shown are approximate. When using a riser clamp in any application other than what it is designed for (i.e., supporting a riser pipe between floors of a building) confirm against the product in hand the hole centers and overall length if they are critical to your installation.

IRON PIPE SIZE	SPECIFICATION DATA				REC. MAX. LOAD (LBS)	APP'X WT. PER 100 (LBS)	PC'S PER PKG.
	See Installation Note Above		BOLT DIAMETER	MATERIAL			
	A	B					
1/2	8 5/8	2 1/8	3/8	8 ga x 1	220	88	25
3/4	8 13/16	2 5/16	3/8	8 ga x 1	220	92	25
1	9 1/16	2 5/8	3/8	8 ga x 1	220	94	25
1 1/4	9 7/16	2 15/16	3/8	8 ga x 1	250	100	25
1 1/2	10	3 7/16	3/8	8 ga x 1	250	104	25
2	10 9/16	4	3/8	8 ga x 1	300	114	25
2 1/2	11 1/8	4 9/16	3/8	3 ga x 1	400	160	25
3	11 13/16	5 1/4	3/8	3 ga x 1	500	170	25
3 1/2	13	6	1/2	3 ga x 1	600	206	25
4	13 5/8	6 5/8	1/2	3 ga x 1	750	220	20
5	14 1/8	7 5/8	1/2	3 ga x 1 1/2	1500	340	10
6	15 3/8	8 7/8	1/2	3 ga x 1 1/2	1600	372	10
8	18 5/8	12	5/8	3/8 x 1 1/2	2500	722	5
10	21	14 1/2	5/8	3/8 x 2	2500	1094	4
12	22 3/4	17	5/8	1/2 x 2	2700	1610	4
14	24	17 7/8	5/8	1/2 x 2	2700	1700	BULK
15	24 1/4	19 1/2	3/4	1/2 x 2 1/2	2800	2300	BULK
16	26	21	3/4	5/8 x 2 1/2	2900	2916	BULK
18	28	23 1/8	3/4	5/8 x 2 1/2	2900	3191	BULK
20	30	25	3/4	5/8 x 2 1/2	2900	3550	BULK
24	36	29 1/4	7/8	5/8 x 2 1/2	2900	4200	BULK
30	42	35 1/4	7/8	5/8 x 3	2900	6000	BULK
36	48	42	1	3/4 x 4	2900	9000	BULK



QWI 4.3.1 Issue Date Dec/15 Rev.21

*Note: when referencing a printed copy of this specification page please insure it is the latest version as found on our website at [www.taylorassociates.com](http://www.taylorassociates.com)*

# #82SS STAINLESS RISER CLAMP

Material: Stainless Steel (#82 304SS) and (#82 316SS)

Approvals: Complies with MSS SP-58 and SP-69 (Type 8).

Recommended: For the support and stabilizing of vertical pipe runs.

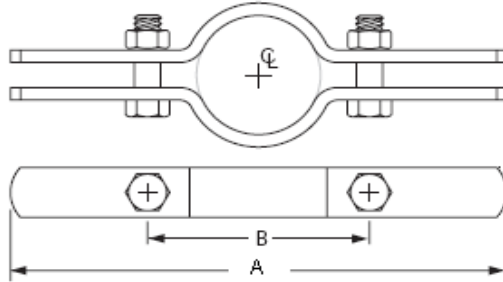

## Installation Note:

The A and B dimensions shown are approximate. When using a riser clamp in any application other than what it is designed for (i.e., supporting a riser pipe between floors of a building) confirm against the product in hand the hole centers and overall length if they are critical to your installation.

IRON PIPE SIZE	SPECIFICATION DATA				REC. MAX. LOAD (LBS)	APP'X WT. PER 100 (LBS)	PC'S PER PKG.
	See Installation Note Above		BOLT DIAMETER	MATERIAL			
	A	B					
1/2	9 5/8	3 1/4	3/8	1/8 x 1 1/4	220	88	25
3/4	10	3 1/4	3/8	1/8 x 1 1/4	220	92	25
1	9 3/4	3 1/4	3/8	1/8 x 1 1/4	220	94	25
1 1/4	10 1/4	4 5/16	3/8	3/16 x 1	250	100	25
1 1/2	10 3/8	4 1/4	3/8	3/16 x 1	250	104	25
2	10 7/16	4 5/16	3/8	3/16 x 1	300	114	25
2 1/2	11 1/8	4 9/16	3/8	1/4 x 1	400	160	25
3	12 1/8	6 3/8	3/8	1/4 x 1	500	170	25
3 1/2	13	6	1/2	1/4 x 1	600	206	25
4	13 3/4	7 1/4	1/2	1/4 x 1	750	220	20
5	14 1/8	7 5/8	1/2	1/4 x 1 1/2	1500	340	10
6	15 5/8	9 1/8	1/2	1/4 x 1 1/2	1600	372	10
8	19	12 3/8	5/8	3/8 x 1 1/2	2500	722	5
10	21 1/8	14 5/8	5/8	3/8 x 2	2500	1094	4
12	22 3/4	17	5/8	1/2 x 2	2700	1610	4
14	24	17 7/8	5/8	1/2 x 2	2700	1700	BULK
16	26 5/16	21 5/16	3/4	5/8 x 2 1/2	2900	2916	BULK
18	28 3/16	23 3/16	3/4	5/8 x 2 1/2	2900	3191	BULK
20	30 3/16	25 1/4	3/4	5/8 x 2 1/2	2900	3550	BULK
24	36	29 1/4	7/8	5/8 x 2 1/2	2900	4200	BULK
30	42	35 1/4	7/8	5/8 x 3	2900	6000	BULK
36	48	42	1	3/4 x 4	2900	9000	BULK



QWI 4.3.1 Issue Date Aug/16 Rev.2

Note: when referencing a printed copy of this specification page please insure it is the latest version as found on our website at [www.taylorassociates.com](http://www.taylorassociates.com)

## HEAVY DUTY RISER CLAMP #82H

- 2" through 24"
- Carbon Steel
- Bare Metal
- Complies with MSS SP-58 and SP-69 (Type 42).
- Recommended for the support and stabilizing of vertical pipe runs.
- Specify pipe size, figure number, name and finish.
- Also available in Electro-Plated Zinc, Stainless Steel, and Hot Dipped Galvanized
- Shear lugs included.

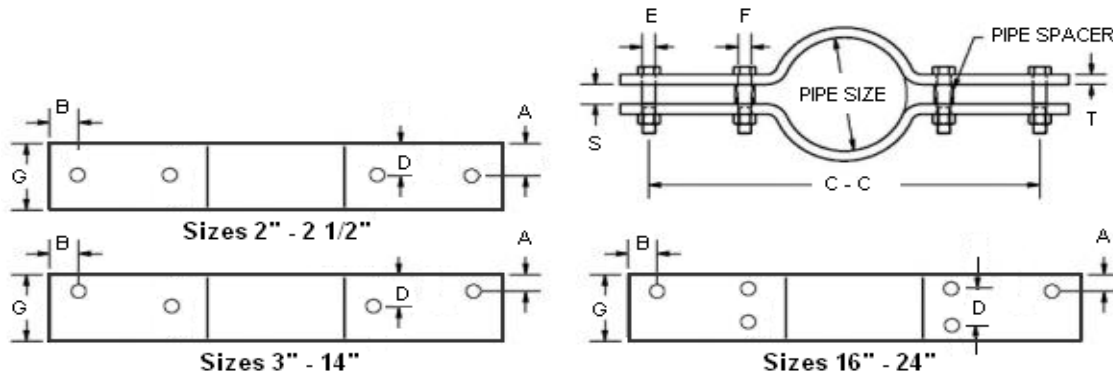

IRON PIPE SIZE	SPECIFICATION DATA									APP'X WT. EACH (LBS)	MAX. REC. LOAD LBS.
	C-C	E	F	G	S	A	D	B	T		
2	18	1/2	1/2	2 1/2	3/4	1 1/4	1 1/4	2	1/2	18	900
2 1/2	20	1/2	1/2	2 1/2	3/4	1 1/4	1 1/4	2	1/2	19	900
3	20	5/8	5/8	3	1	1 1/4	1 1/2	2	5/8	29	1500
4	22	3/4	3/4	4	1 1/4	1 1/4	2	2	3/4	50	2200
5	22	3/4	3/4	4	1 1/4	1 1/4	2	2	3/4	51	2200
6	24	7/8	7/8	5	1 1/2	1 1/4	2 1/2	2	3/4	70	3000
8	27	7/8	7/8	5	1 1/2	1 1/4	2 1/2	2	3/4	78	3000
10	30	1 1/4	1 1/4	6	2 1/4	1 5/8	3	3	1	150	5500
12	32	1 1/2	1 1/2	7	2 1/2	1 7/8	3 1/2	3	1	193	7800
14	34	1 1/2	1 1/2	7	2 1/2	1 7/8	3 1/2	3	1	204	7800
16	36	1 1/2	1 1/8	6	2 1/2	2	3	3	1 1/4	224	9000
18	39	1 1/2	1 1/8	7	2 1/2	2	3	3	1 1/4	280	9000
20	42	2	1 1/2	8	3 1/2	2 5/8	4	4 1/4	1 1/2	429	13500
24	45	2	1 1/2	8	3 1/2	2 5/8	4	4 1/4	1 1/2	465	13500

Pipe Size	Shear Lug	Lugs Required
2 - 2 1/2	1/2 x 1/2 x 3	2
3	5/8 x 5/8 x 3	2
4 - 8	3/4 x 3/4 x 3	2
10 - 14	1 x 1 x 3	4
16 - 24	1 1/4 x 1 1/4 x 3	4



QWI 4.3.1 Issue Date May/16 Rev. 3

*Note: when referencing a printed copy of this specification page please insure it is the latest version as found on our website at [www.taylorassociates.com](http://www.taylorassociates.com)*

## RISER CLAMP

### Epoxy Coated Copper-Gard #85

- 1/2" through 6"
- Carbon Steel
- Epoxy Coated Copper-Gard c/w Zinc Hardware
- Complies with MSS SP-58 and SP-69 (Type 8).
- Recommended for the support and stabilizing of vertical copper tubing pipe runs.
- Specify pipe size, figure number and name.

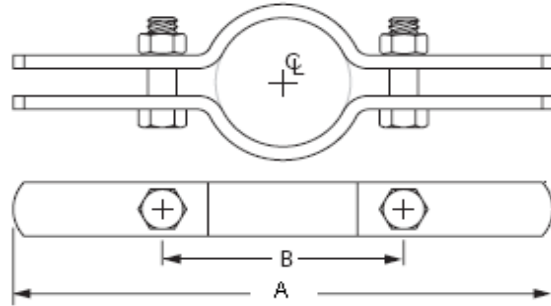

#### Installation Note:

The A and B dimensions shown are approximate. When using a riser clamp in any application other than what it is designed for (i.e.. supporting a riser pipe between floors of a building) confirm against the product in hand the hole centers and overall length if they are critical to your installation.

COPPER TUBE SIZE	SPECIFICATION DATA				REC. MAX. LOAD (LBS)	APP'X WT. PER 100 PCS	PC'S PER PKG.
	See Installation Note Above		BOLT DIAMETER	MATERIAL			
	A	B					
1/2	6 11/16	1 11/16	1/4	11Ga x 1	225	48	50
3/4	7	2	1/4	11Ga x 1	225	50	50
1	8 3/4	2 1/4	1/4	11Ga x 1	250	64	50
1 1/4	9	2 1/2	1/4	11Ga x 1	250	66	50
1 1/2	9 3/8	2 7/8	1/4	11Ga x 1	250	68	50
2	9 15/16	3 3/8	3/8	8Ga x 1	500	106	25
2 1/2	10 1/2	4	3/8	8Ga x 1	500	108	25
3	11	4 7/16	3/8	8Ga x 1	500	116	25
3 1/2	12 3/16	5 1/8	3/8	8Ga x 1 1/4	500	158	25
4	12 5/8	5 9/16	3/8	8Ga x 1 1/4	500	166	25
5	14 1/8	7 1/8	1/2	3Ga x 1 1/2	815	342	10
6	15	8	1/2	3Ga x 1 1/2	815	376	10



QWI 4.3.1 Issue Date Aug/16 Rev.9

*Note: when referencing a printed copy of this specification page please insure it is the latest version as found on our website at [www.taylorassociates.com](http://www.taylorassociates.com)*

### OFFSET PIPE CLAMP #87

- 3/4" through 12"
- Carbon Steel
- Bare Metal
- Designed to support general piping, running from wall or floor. This clamp can be furnished with "L" dimensions to suit field conditions.
- Specify pipe size, figure number, name and finish.
- Also available in Electro-Plated Zinc, Stainless Steel, Epoxy, and Hot Dipped Galvanized

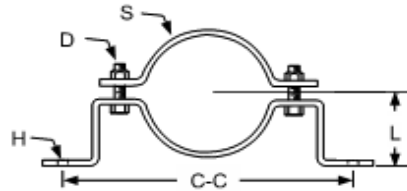

IRON PIPE SIZE	SPECIFICATION DATA					RECOM. MAX. LOAD (LBS)	APP'X WT. PER 100 (LBS)
	L	C-C	D	H	S		
3/4	2 1/2	7 3/16	3/8	7/16	1/4 x 1 1/4	200	125
1	2 5/8	7 9/16	3/8	7/16	1/4 x 1 1/4	200	133
1 1/4	2 13/16	7 7/8	3/8	7/16	1/4 x 1 1/4	200	142
1 1/2	2 15/16	8 1/4	3/8	7/16	1/4 x 1 1/4	200	149
2	3 3/16	9 1/8	3/8	7/16	1/4 x 1 1/4	410	203
2 1/2	3 7/16	10 1/2	3/8	7/16	1/4 x 1 1/4	410	225
3	3 3/4	11 1/8	3/8	7/16	1/4 x 1 1/4	410	250
3 1/2	4	11 5/8	3/8	7/16	1/4 x 1 1/4	410	275
4	4 1/4	12 1/2	1/2	9/16	1/4 x 1 1/2	600	368
5	4 3/4	13 3/4	1/2	9/16	1/4 x 1 1/2	600	425
6	5 5/16	16 1/2	1/2	9/16	3/8 x 1 1/2	850	680
8	6 5/16	18 5/8	1/2	9/16	3/8 x 1 1/2	850	820
10	7 3/4	23	3/4	13/16	3/8 x 3	870	2142
12	8 3/4	25	3/4	13/16	3/8 x 3	870	2337



QWI 4.3.1 Issue Date Mar/12 Rev.3

*Note: when referencing a printed copy of this specification page please insure it is the latest version as found on our website at [www.taylorassociates.com](http://www.taylorassociates.com)*



## EXTENDED PIPE CLAMP #88

- 3/4" through 8"
- Carbon Steel
- Bare Metal
- Designed for direct welding of hanger to steel structure
- Specify pipe size, figure number, name and finish.
- Also available in Electro-Plated Zinc, Stainless Steel, Epoxy, and Hot Dipped Galvanized

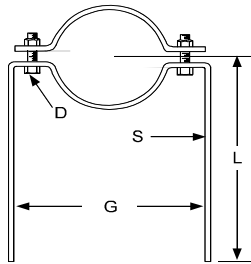

PIPE SIZE	SPECIFICATION DATA				APP'X WT. PER 100 (LBS)
	L	D	G	S	
3/4	12	3/8	4 7/16	1/4 x 1 1/4	185
1	12	3/8	4 11/16	1/4 x 1 1/4	234
1 1/4	12	3/8	5	1/4 x 1 1/4	240
1 1/2	12	3/8	5 1/4	1/4 x 1 1/4	245
2	12	1/2	6	1/4 x 1 1/2	313
2 1/2	12	1/2	7 1/4	1/4 x 1 1/2	420
3	12	1/2	7 7/8	1/4 x 1 1/2	447
3 1/2	12	1/2	8 3/8	1/4 x 1 1/2	474
4	12	1/2	9 1/4	1/4 x 1 1/2	490
5	12	1/2	10 1/2	1/4 x 1 1/2	532
6	12	5/8	12 1/2	3/8 x 2	1115
8	12	5/8	14 5/8	3/8 x 2	1265



QWI 4.3.1 Issue Date Mar/12 Rev.2

*Note: when referencing a printed copy of this specification page please insure it is the latest version as found on our website at [www.taylorassociates.com](http://www.taylorassociates.com)*

### ADJUSTABLE ROD BEAM CLAMP #159

- 3/8" through 5/8" rod size
- Carbon Steel
- Bare Metal
- Complies with MSS SP-58 and MSS SP-69 (Type 27)
- Designed to be used in the suspension of a hanger rod from an I beam. Recommended for flange widths from 4" minimum to 8" maximum.
- Specify rod size, figure number, name and finish.
- Also available in Electro-Plated Zinc

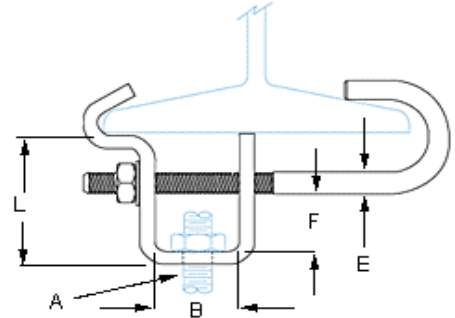
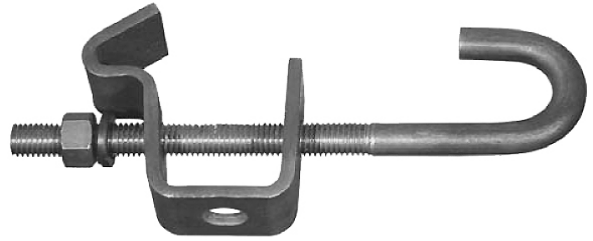

ROD SIZE A	MATERIAL	FLANGE WIDTH		B	E	F	L	WEIGHT EACH (LBS)	MAX. REC. LOAD (LBS)
		MIN	MAX						
3/8 - 16	3 Ga x 1 1/4	3 1/2	8	2	3/8	1	2 3/4	0.98	300
1/2 - 13	3 Ga x 1 1/2	3 1/2	8	2	1/2	15/16	2 3/4	1.38	700
5/8 - 11	3 Ga x 1 3/4	3 1/2	8	2	5/8	7/8	2 3/4	1.86	1000



QWI 4.3.1 Issue Date Novv/13 Rev.2

*Note: when referencing a printed copy of this specification page please insure it is the latest version as found on our website at [www.taylorassociates.com](http://www.taylorassociates.com)*

# #201 Stamped "C" Clamp

**Finish:** Bare Metal, Zinc Plated

**Material:** Carbon Steel, Stainless Steel 304SS & 316SS

**Approvals:** Complies with MSS SP-58 and SP-69 (Type 23)  
 (3/8" and 1/2") cUL, FM for 4" I.P. Max (Mild Steel Only)  
 (3/8" and 1/2") cUL, for 4" I.P. Max (Stainless Steel)

**Recommended:** Designed for fastening to beam flange where thickness does not exceed 0.75 inches.

**Note:** Stainless Steel Only Available up to 3/4"

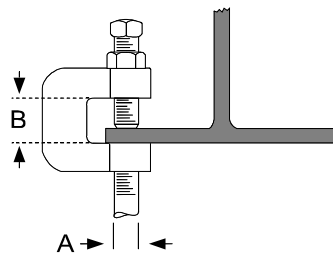

ROD SIZE A	SPECIFICATION DATA		APP'X WT. PER 100 (LBS.)	RECOM. MAX. LOAD (LBS)	PC'S PER PACKAGE
	B				
3/8	3/4		41	400	100
1/2	3/4		42	500	100
5/8	3/4		60	550	50
3/4	3/4		68	630	50
7/8	3/4		188	700	50



QWI 4.3.1 Issue Date Apr/18 Rev.6

Note: when referencing a printed copy of this specification page, please insure it is the latest version as found on our website at [www.taylorassociates.com](http://www.taylorassociates.com)

For more information, please contact Customer Service at 1-800-263-8652

**MALLEABLE "C" CLAMP #301**

- 3/8" through 3/4"
- Malleable Iron\* c/w hardened steel cup point set screw
- Bare Metal
- Complies with MSS SP-58 and SP-69 (Type 23).
- (3/8" and 1/2") CUL, FM for 4" I.P. Max.
- Recommended for attachment to American Standard I-Beams and wide flange beams where thickness does not exceed 3/4"
- Specify size, figure number, name and finish.
- Also available in Electro-Plated Zinc



Maximum recommended set screw torque values per MSS SP-69.

Set Screw Size 3/8"-16  
Foot-Lbs 5  
Nm 7

(CARE SHOULD BE TAKEN NOT TO OVER TIGHTEN SET SCREW)

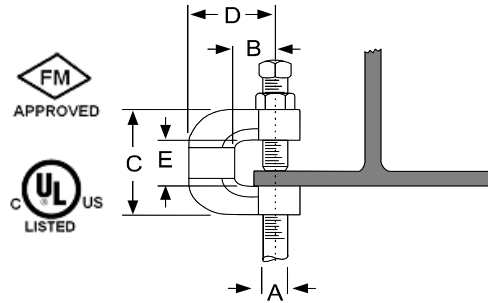

ROD SIZE	SPECIFICATION DATA				PIPE SIZE	RECOM. MAX. LOAD (LBS)	APPR'X WT. PER 100 (LBS)	PC'S PER PKG.
	A	B	C	D				
3/8	5/8	1 3/4	1 7/16	3/4	1/2 to 2	350	31	100
1/2	5/8	1 3/4	1 7/16	3/4	2 1/2 to 3 1/2	500	32	100
5/8	5/8	1 29/32	1 13/32	3/4	4 to 5	550	42	50
3/4	5/8	2 1/16	1 1/2	3/4	6	630	51	50



QWI 4.3.1 Issue Date Mar/12 Rev.5

*Note: when referencing a printed copy of this specification page please insure it is the latest version as found on our website at [www.taylorassociates.com](http://www.taylorassociates.com)*

# #404 Purlin Clamp

**Finish:** Bare Metal, Zinc Plated

**Material:** Malleable Iron\* c/w hardened steel cup point set screw

**Approvals:** Complies with MSS SP-58 and SP-69 (Type 23)

**Recommended:** Designed for use with large-lip rolled steel purlins to eliminate the need to modify steel purlin for standard C-Clamp

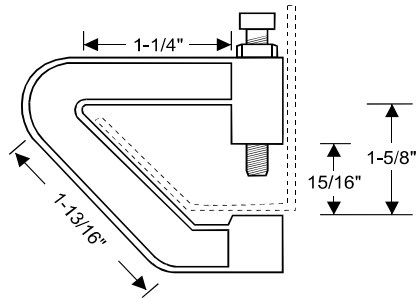

Maximum recommended set screw torque values per MSS SP-69.

Set Screw Size 3/8"-16  
 Foot-Lbs 5  
 Nm 7

(CARE SHOULD BE TAKEN NOT TO OVER TIGHTEN SET SCREW)

ROD SIZE A	SPECIFICATION DATA		APPROX. WEIGHT PER 100 PCS./LBS	PC'S PER PKG.
	MAX. PIPE SIZE	MAX. REC. LOAD/LBS		
3/8	4"	400	82	50



QWI 4.3.1 Issue Date Mar/16 Rev.5

Note: when referencing a printed copy of this specification page, please insure it is the latest version as found on our website at [www.taylorassociates.com](http://www.taylorassociates.com)

For more information, please contact Customer Service at 1-800-263-8652

### INSULATOR SUPPORT #405

- 1/4" through 3/8"
- Malleable Iron
- Electro-Plated Zinc
- Designed to attach hanger rod to beam or framework where thickness does not exceed 1/2 inch. Rod tap on both bottom and back of clamp.
- Specify rod size, figure number, name and finish.
- Also available in Stainless Steel

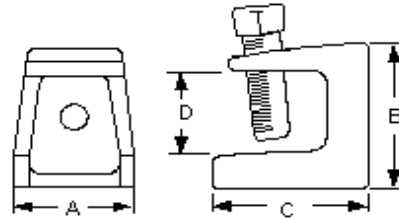

(CARE SHOULD BE TAKEN NOT TO OVER TIGHTEN SET SCREW)

ROD SIZE	SPECIFICATION DATA				APP'X WT. PER 100 (LBS)	REC. MAX. LOAD (LBS)	PC'S PER PKG.
	A	B	C	D			
1/4	1 3/16	1 3/8	1 3/8	3/4	26	335	100
5/16	1 3/16	1 3/8	1 3/8	3/4	25	335	100
3/8	2 1/16	1 3/4	1 7/8	1	70	525	25



QWI 4.3.1 Issue Date Nov/13 Rev.5

*Note: when referencing a printed copy of this specification page please insure it is the latest version as found on our website at [www.taylorassociates.com](http://www.taylorassociates.com)*

# #406 Small Mouth Top Beam Clamp

**Finish:** Bare Metal, Zinc Plated

**Material:** Malleable Iron\* c/w hardened steel cup point set screw  
Stainless Steel 304SS & 316SS

**Approvals:** U.L. - U.L.C. listed 3/8 and 1/2 (1/2 for 4" IPS max).  
**FM approved for 3/8" only.**  
Complies with Manufacturers' Standardization Society  
MSS SP-58 and SP-69 (Type 19)

**Recommended:** Recommended for use under roof installations with  
bar joist type construction where flange thickness does  
not exceed 5/8 inch.

**Note:** Stainless Steel Only Available up to 3/4"

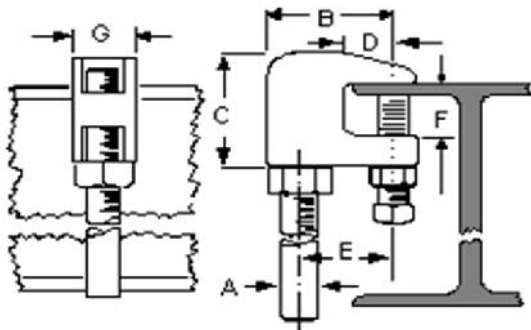

Maximum recommended set screw torque values per

MSS SP-69.

Set Screw Size 3/8"-16

Foot-Lbs 5

Nm 7

(CARE SHOULD BE TAKEN NOT TO OVER TIGHTEN SET SCREW)

\*\* Approvals on stainless steel - cUL for 3/8" and 1/2" only (4" I.P. Max.)

ROD SIZE A	SPECIFICATION DATA						MAX. PIPE SIZE	RECOM. MAX. LOAD (LBS)	APPR'X WT. PER 100 (LBS)	PC'S PER PKG.
	B	C	D	E	F	G				
3/8	1 15/16	1 1/2	1/2	1	3/4	7/8	4	610	32	100
1/2	1 5/16	1 1/2	1/2	1	3/4	7/8	4	1130 *	32	100
5/8	1 3/4	1 3/4	5/8	1 3/8	3/4	1 1/8	5	1130	58	50
3/4	1 7/8	1 7/8	5/8	1 3/8	3/4	1 3/8	6	1130	82	50
7/8	2 3/8	1 7/8	5/8	1 3/8	3/4	1 3/8	8	1130	80	50

\*750 if inverted



QWI 4.3.1 Issue Date Aug/18 Rev.15

Note: when referencing a printed copy of this specification page, please insure it is the latest version as found on our website at [www.taylorassociates.com](http://www.taylorassociates.com)

For more information, please contact Customer Service at 1-800-263-8652



# #407 Wide Mouth Top Beam Clamp

**Finish:** Bare Metal, Zinc Plated

**Material:** Malleable Iron\* c/w hardened steel cup point set screw

**Approvals:** U.L. - U.L.C. listed 3/8 and 1/2 (1/2 for 4" IPS max).

**FM approved for 3/8" only.**

Complies with Manufacturers' Standardization Society  
MSS SP-58 and SP-69 (Type 19)



**Recommended:** Recommended for use under roof installations with bar joist type construction, or for attachment to top flange of structural shapes.

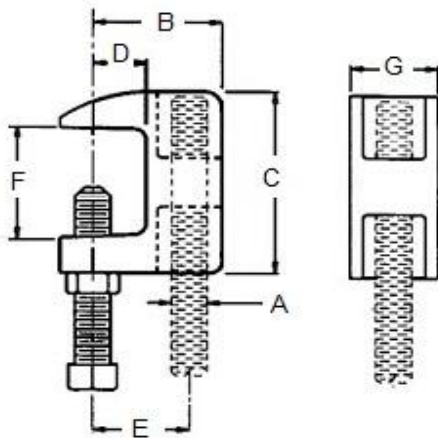

Maximum recommended set screw torque values per

MSS SP-69.

Set Screw Size 3/8"-16

Foot-Lbs 5

Nm 7

(CARE SHOULD BE TAKEN NOT TO OVER TIGHTEN SET SCREW)

ROD SIZE A	SPECIFICATION DATA						MAX. PIPE SIZE	RECOM. MAX. LOAD (LBS)	APPR'X WT. PER 100 (LBS)	PC'S PER PKG.
	B	C	D	E	F	G				
3/8	1 3/8	2	1/2	1	1 1/4	7/8	4	610	55	100
1/2	1 3/8	2	1/2	1	1 1/4	7/8	4	1130 *	56	100
5/8	1 7/8	2 3/8	5/8	1 3/8	1 1/4	1 1/4	5	1130	66	50
3/4	1 7/8	2 3/8	5/8	1 3/8	1 1/4	1 1/4	6	1130	83	50



\*750 if inverted

QWI 4.3.1 Issue Date Aug/18 Rev.13

Note: when referencing a printed copy of this specification page, please insure it is the latest version as found on our website at [www.taylorassociates.com](http://www.taylorassociates.com)

For more information, please contact Customer Service at 1-800-263-8652

**MALLEABLE BEAM CLAMP #410**  
(order extension piece seperately Fig# 411)

- Flange Width of 2 3/8" through 7"
- Malleable Iron Jaw, Carbon Steel Hardware
- Bare Metal
- Complies with MSS SP-58 and MSS SP-69 (Type 30) when used with Extension Piece Fig# 411
- Designed for attaching a hanger rod to the bottom flange of a beam. Flange thickness not to exceed 0.60"
- Specify figure number, name and finish.
- Also available in Electro-Plated Zinc

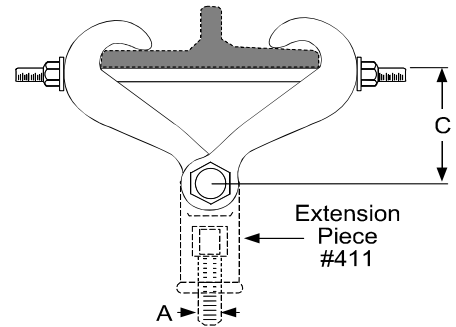

A (7/8 MAX ROD)	SPECIFICATION DATA						BOLT DIA.	RECOM. MAX. LOAD (LBS.)	APP'X WT PER 100 (LBS.)
	ROD TAKE-OUT "C" FOR WIDTH OF BEAM FLANGE								
	2 3/8"	3"	4"	5"	6"	7"			
3/8 - 7/8	3 1/2	3 7/16	3 5/16	2 15/16	2 9/16	1 7/8	7/16	1365	249



QWI 4.3.1 Issue Date Mar/12 Rev.5

*Note: when referencing a printed copy of this specification page please insure it is the latest version as found on our website at [www.taylorassociates.com](http://www.taylorassociates.com)*

**RETAINING STRAP #416**

- 6" through 12"
- Carbon Steel
- Pre-Galvanized
- Designed for use with top beam clamps.
- Specify size, figure number, name and finish

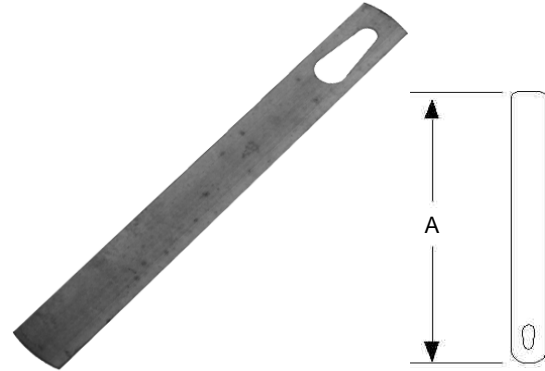

FOR DETERMINING MIN. LENGTH OF STRAP, ADD TWO INCHES TO WIDTH OF FLANGE.

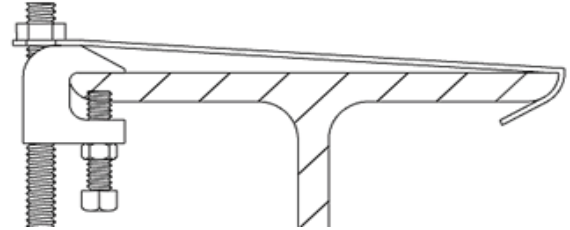

**Note:** Tear-drop hole accommodates 3/8" - 1/2" maximum bolt diameter.

A	SPECIFICATION DATA		APPROX. WT. PER 100 PCS.	PCS. PER PKG.
	MATERIAL		(LBS)	
6	18 ga x 1		8	200
9	18 ga x 1		12	200
12	18 ga x 1		16	200



QWI 4.3.1 Issue Date Sept/09 Rev.4

*Note: when referencing a printed copy of this specification page please insure it is the latest version as found on our website at [www.taylorassociates.com](http://www.taylorassociates.com)*

**BEAM CLAMP #425**

(order Fig# 64 Weldless Eye Nut separately)

4" through 12" Flange Width

Carbon Steel

Bare Metal

Complies with MSS SP-58 and MSS SP-69 (Type 21).

Designed for attaching a hanger rod centered under beam flanges.

Specify clamp size, flange width &amp; thickness, figure number, and finish.

Also available in Electro-Plated Zinc, and Stainless Steel

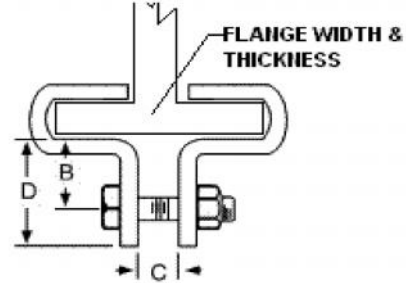

**Note:** Determine the clamp size by the load to be carried on each clamp.

CLAMP SIZE	SPECIFICATION DATA					REC. MAX. LOAD (LBS.)
	B	C	D	MATERIAL	BOLT SIZE	
1	1 1/8	5/8	1 3/4	1/4 x 1 1/4	1/2	1000
2	1 1/8	7/8	2 5/8	1/2 x 2	3/4	3000

Flange	
Width	Max. Thk.
4	1/2
5	5/8
5 1/2	5/8
6	3/4
6 1/2	3/4
7	7/8
8	7/8
9	1
10	1
12	1



QWI 4.3.1 Issue Date Sept/18 Rev.11

*Note: when referencing a printed copy of this specification page please insure it is the latest version as found on our website at [www.taylorassociates.com](http://www.taylorassociates.com)*

## STEEL BEAM CLAMP #426

4" through 8" Flange Width

Carbon Steel

Bare Metal

Designed for attaching a hanger rod centered under beam flanges.

Specify clamp size, flange width and thickness, figure number, and finish

Also available in Electro-Plated Zinc, and Stainless Steel

**Note:** Determine the clamp size by the load to be carried on each clamp.

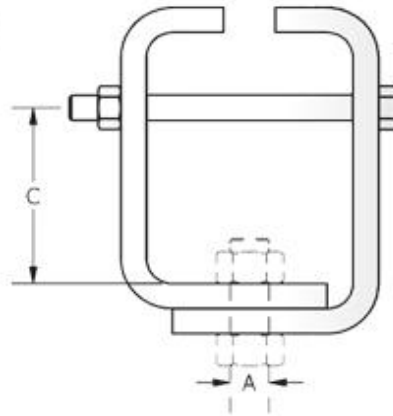
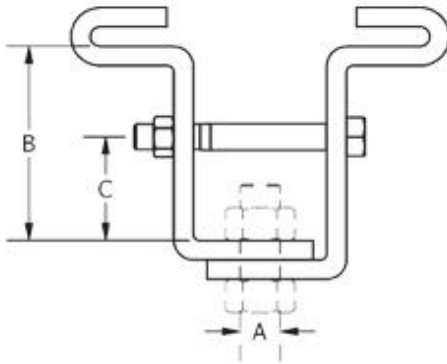
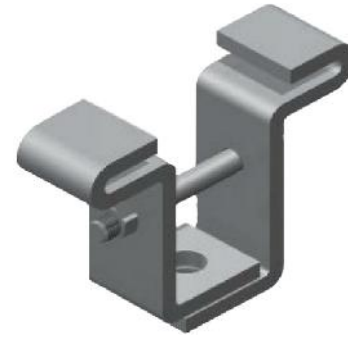

CLAMP SIZE	Max. Flange Thickness	SPECIFICATION DATA				REC. MAX. LOAD
		A	B	C	MATERIAL	
2	1/2	1/2	4	3	1/4 x 1 1/2	850
3	1/2	5/8	4 1/2	3 1/4	3/8 x 1 1/2	1100
4	1/2	3/4	4 1/2	3 1/4	3/8 x 2	1500
5	1/2	7/8	5	3 1/2	1/2 x 2	2600
6	1/2	1	5	3 1/2	1/2 x 2 1/2	4300

Sizes #5 to #6 with flanges 5" and less are box style



QWI 4.3.1 Issue Date Sept/18 Rev.9

*Note: when referencing a printed copy of this specification page please insure it is the latest version as found on our website at [www.taylorassociates.com](http://www.taylorassociates.com)*

**HEAVY BEAM CLAMP #450**

(order Fig# 64 Weldless Eye Nut separately)

- 3" through 16" Flange Width
- ASTM A-36 carbon steel.
- Bare Metal
- Complies with MSS SP-58 and SP-69 (Type 28 without links, Type 29 with links.)
- Designed for suspension of heavy loads from beams up to 16" wide and up to 1" thick.
- Specify clamp size, figure number, rod size and finish.
- Also available in Electro-Plated Zinc

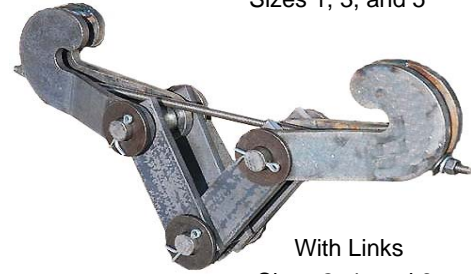
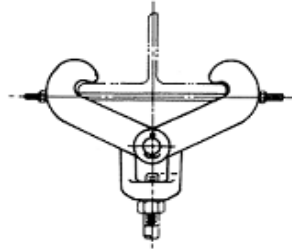
Without Links  
Sizes 1, 3, and 5With Links  
Sizes 2, 4, and 6

SIZE	FLANGE SIZE		MAX ROD	WGT. EACH (LBS)	MAX LOAD
	WIDTH	MAX THICKNESS			
1	3 - 8	5/8	3/4	8	2800
2	7 - 12*	5/8	3/4	12	2800
3	3 - 8	3/4	1	11	5000
4	7 - 15*	3/4	1	16	5000
5	5 - 11	1	1 1/2	30	11500
6	8 - 16*	1	1 1/2	48	11500

\* Supplied with links



QWI 4.3.1 Issue Date May/15 Rev.7

*Note: when referencing a printed copy of this specification page please insure it is the latest version as found on our website at [www.taylorassociates.com](http://www.taylorassociates.com)*

# #28R Ceiling Flange

**Finishes:** Bare Metal, Zinc Plated, Copper Gard Epoxy Coating

**Materials:** Malleable Iron, Stainless Steel 304SS & 316SS

**Recommended:** For attaching a hanger rod to beams or ceilings.

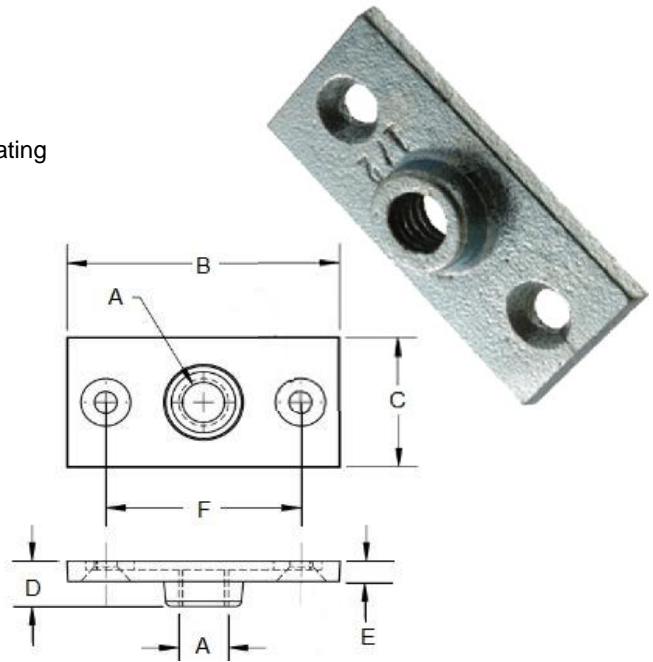

ROD SIZE	SPECIFICATION DATA					MAX BOLT DIA.	RECOM. MAX. LOAD (LBS)	APP'X WT. PER 100 (LBS)	PC'S PER PKG.
	A	B	C	D	E				
1/4"	2 11/16	1 3/8	1/2	3/16	2	1/4	180 #	17	100
3/8	2 11/16	1 3/8	1/2	3/16	2	1/4	180 #	17	100
1/2	2 11/16	1 3/8	1/2	3/16	2	1/4	180 #	18	100



QWI 4.3.1 Issue Date Sept/18 Rev.6

Note: when referencing a printed copy of this specification page, please insure it is the latest version as found on our website at [www.taylorassociates.com](http://www.taylorassociates.com)

For more information, please contact Customer Service at 1-800-263-8652



**STRUCTURAL WELDING LUG #55 Short**  
**STRUCTURAL WELDING LUG #55L Long**

- 1/2" through 3 3/4" rod size
- Carbon Steel
- Bare Metal
- Complies with MSS SP-58 and SP-69 (Type 57).
- Designed to be welded to structural members and used in conjunction with Figure #63 forged steel clevis with pin and cotters.
- Specify rod size, figure number, name, finish, and whether long or short lug is required.
- Also available in Electro-Plated Zinc, Stainless Steel, and Hot Dipped Galvanized

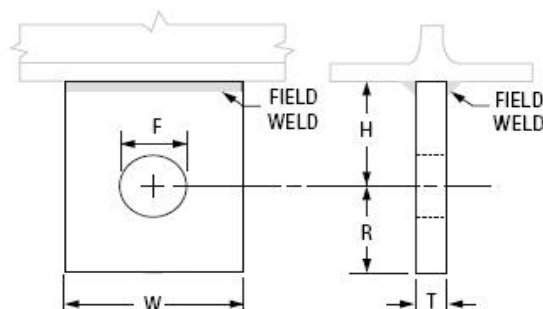

ROD SIZE A*	Pin or Bolt Dia.	SPECIFICATION DATA								MAX REC LOAD (LBS)	
		FIG # 55 , #55L				FIG # 55		FIG #55L		650°	750°
		F	R	T	W	Rod Take Out - H	Weight (Lbs.)	Rod Take Out - H	Weight (Lbs.)		
1/2	5/8	11/16	1 1/4	1/4	2 1/2	1 1/2	0.5	3	0.75	1350	1057
5/8	3/4	13/16		0.4			0.68		2160	1692	
3/4	7/8	15/16		3/8			0.6		1.0	3230	2530
7/8	1	1 1/8		0.7			0.98		4480	3508	
1	1 1/8	1 1/4	1 1/2	1/2	3	2	1.2	1.6	5900	4620	
1 1/4	1 3/8	1 1/2	2	5/8	4	3	3.0	4	3.7	9500	7440
1 1/2	1 5/8	1 3/4	2 1/2	3/4	5		4.8	4 1/2	6.4	13800	10807
1 3/4	1 7/8	2				4.7	6.3		18600	14566	
2	2 1/4	2 3/8	3	6	6	4	7.2	8.8	24600	19265	
2 1/4	2 1/2	2 5/8	3			4 1/2	4 1/2	7.6	--	--	32300
2 1/2	2 3/4	2 7/8		4	1			8	15.5	--	--
2 3/4	3	3 1/8	4 1/2			1 1/2	9		15.1	--	--
3	3 1/4	3 3/8		5	1 3/4			9	16.0	--	--
3 1/4	3 1/2	3 5/8	6			9	9		18.9	--	--
3 1/2	3 3/4	3 7/8		6	9			9	31.3	--	--
3 3/4	4	4 1/8	35.9			--	--		98500	77139	

\* Note: Rod Size "A" is the assembly rod diameter. Dimension not shown on drawing.



QWI 4.3.1 Issue Date Apr/13 Rev.0

Note: when referencing a printed copy of this specification page please insure it is the latest version as found on our website at [www.taylorassociates.com](http://www.taylorassociates.com)

# #66 Welded Beam Attachment

## #67 Welded Beam Attachment Without Hardware

**Finishes:** Bare Metal, Zinc Plated, Hot Dipped Galvanized

**Materials:** Carbon Steel, Stainless Steel 304SS & 316SS

**Approvals:** Complies with MSS SP-58 and SP-69 (Type 22).

**Recommended:** For attachment to bottom of beams where heavier loads are being supported

Maximum temperatures: Bare Metal 750°F, Galvanized 450°F

**Note:** #67 available up to 1 3/4"

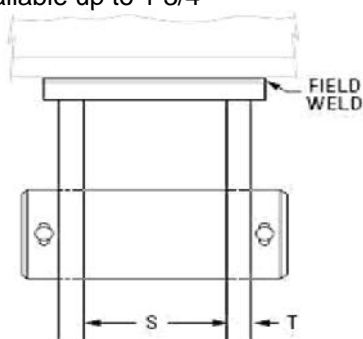

2" Rod Dia. and Larger are Fabricated.

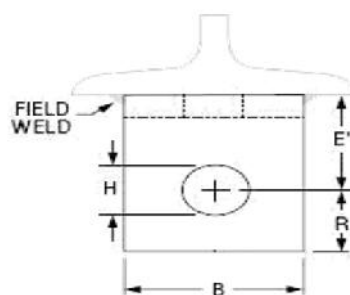

1 3/4" Rod Dia. and Smaller are Formed using Bolt or Pin.

ROD SIZE A	SPECIFICATION DATA						RECOM. LOAD 650°F	RECOM. LOAD 750°F	BOLT or PIN SIZE	APP'X WT PER 100 (LBS)
	E*	B	H	R	S	T				
3/8	2	2	9/16	7/8	1 1/4	1/4	730	572	1/2 x 2 1/2	117
1/2	2	2	11/16	7/8	1 1/4	1/4	1350	1057	5/8 x 2 3/4	131
5/8	2	2	13/16	7/8	1 1/4	1/4	2160	1692	3/4 x 2 3/4	155
3/4	2	2 1/2	15/16	1 1/8	1 7/8	3/8	3230	2530	7/8 x 4	279
7/8	3	2 1/2	1 1/8	1 1/4	2	3/8	4480	3508	1 x 4	394
1	3	3	1 1/4	1 1/2	2 3/4	1/2	5900	4620	1 1/8 x 5	629
1 1/4	3	4	1 1/2	2	3	5/8	9500	7440	1 3/8 x 6 1/2	1022
1 1/2	4	5	1 3/4	2 1/2	3 1/2	3/4	13800	10807	1 5/8 x 6 1/2	1902
1 3/4	5	5	2	2 3/4	3 3/4	3/4	18600	14566	1 7/8 x 6 7/8	2418
2	5	6	2 3/8	3 1/4	3 1/2	1/2	24600	19265	2 1/4 x 6 7/8	3055
2 1/4	5 3/4	6	2 5/8	3 1/2	3 1/2	5/8	32300	25295	2 1/2 x 7 3/8	3678
2 1/2	5 3/4	6	2 7/8	3 3/4	3 3/4	5/8	39800	31169	2 3/4 x 7 5/8	3970
2 3/4	5 3/4	6	3 1/8	4	3 3/4	5/8	49400	38687	3 x 7	4080
3	6 1/4	7	3 3/8	4	3 3/4	5/8	60100	47066	3 1/4 x 7	4670
3 1/4	7	7	3 5/8	4 1/2	4 1/4	3/4	71900	56307	3 1/2 x 7 3/4	6210
3 1/2	7 1/2	8	3 7/8	4 1/2	4 1/4	3/4	84700	66331	3 3/4 x 7 3/4	7240



QWI 4.3.1 Issue Date May/18 Rev.7

Note: when referencing a printed copy of this specification page, please insure it is the latest version as found on our website at [www.taylorassociates.com](http://www.taylorassociates.com)

For more information, please contact Customer Service at 1-800-263-8652

### STEEL WASHER PLATE #80

- 3/16" x 3" through 3/4" x 7"
- Carbon Steel
- Bare Metal
- Designed as a heavy duty washer to suspend hanger rods.
- Specify rod size, thickness, length and width, and figure number.
- Also available in Electro-Plated Zinc, Stainless Steel, and Hot Dipped Galvanized
  
- Note:** Other sizes available upon request

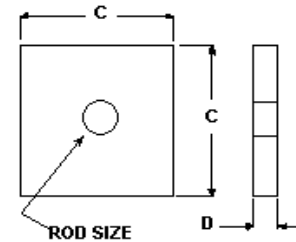

Rod Size	PLATE SIZE D x C x C	Hole Dia.	Wt Each
3/8	3/16" x 3" x 3"	7/16	0.5
1/2		9/16	0.4
3/8	1/4" x 2" x 2"	7/16	0.3
1/2		9/16	0.3
3/8	1/4" x 3" x 3"	7/16	0.6
1/2		9/16	0.6
5/8	3/8" x 3" x 3"	11/16	0.9
5/8		11/16	1.7
3/4		13/16	1.7
7/8		15/16	1.6
1	1/2" x 4" x 4"	1 1/8	1.6
7/8		15/16	2.2
1	1/2" x 5" x 5"	1 1/8	2.1
1 1/4		1 1/2	3.3
1 1/2	3/4" x 5" x 5"	1 3/4	4.8
1 3/4		2	4.7
2		2 1/4	4.5
2 1/4	3/4" x 6" x 6"	2 1/2	6.6
2 1/2		2 3/4	6.4
2 3/4		3	6.2
3		3 1/4	5.9
3 1/4		3 1/2	5.6
3 1/2		3/4" x 7" x 7"	3 3/4
3 3/4	4		7.8



QWI 4.3.1 Issue Date Mar/13 Rev.3

*Note: when referencing a printed copy of this specification page please insure it is the latest version as found on our website at [www.taylorassociates.com](http://www.taylorassociates.com)*

**CONCRETE INSERT #81**  
**CONCRETE INSERT NUT #81N**

- Carbon Steel
- Bare, Electro-Plated Zinc, Painted
- Heavy gauge insert box is nailed to concrete form. When concrete has set, knock out plug can be removed and insert nut installed. Side openings accommodate up to 1/2" reinforcing rods.
- Complies with MSS SP-58 and MSS SP-69 (Type 18).
- Specify figure number, name, and finish.
- For Insert Nut #81N specify figure number, name, finish, and rod size.

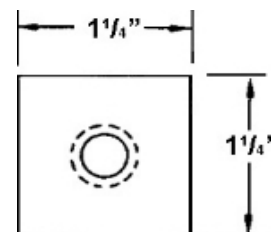
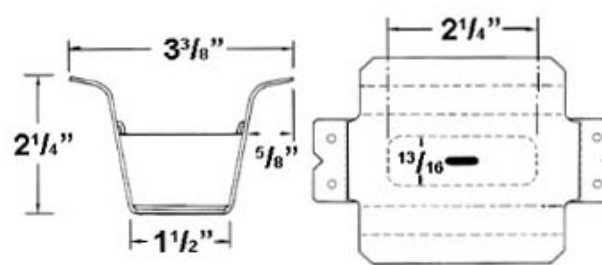
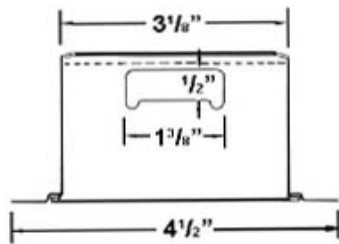
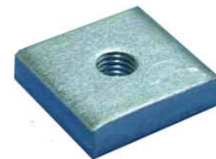

# 81N Insert Nut

SIZE A	WEIGHT EACH (Lbs.)		MAX. REC. LOAD (Lbs.)
	Insert (Fig# 81)	Nut (Fig# 81N)	
3/8 - 16	0.61	0.12	610
1/2 - 13	0.61	0.12	800
5/8 - 11	0.61	0.10	800
3/4 - 10	0.61	0.10	800



QWI 4.3.1 Issue Date Apr/13 Rev.0

*Note: when referencing a printed copy of this specification page please insure it is the latest version as found on our website at [www.taylorassociates.com](http://www.taylorassociates.com)*

**45° BRACING ATTACHMENT #115**

- Pre-Galvanized Mild Steel
- Designed as a bracing attachment for wire rope bracing

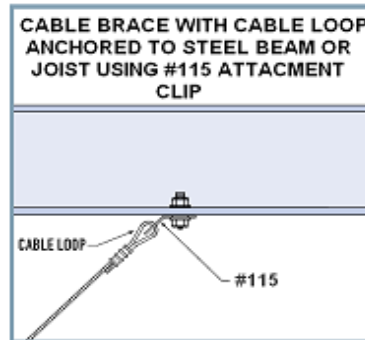
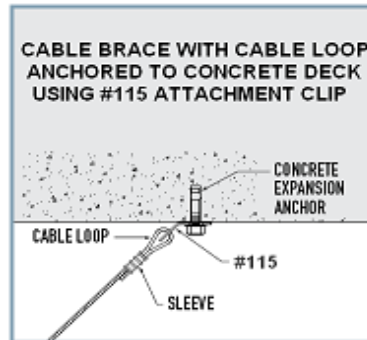

SPECIFICATION DATA		MATERIAL	APP'X WT. PER 100 (LBS)	PC'S PER PKG.
Mounting Hole for 3/8" Bolt	Wire Bracing Attachment Hole			
7/16"	3/4"	11Ga x 1 1/2	13	100



QWI 4.3.1 Issue Date Feb/12 Rev.0

*Note: when referencing a printed copy of this specification page please insure it is the latest version as found on our website at [www.taylorassociates.com](http://www.taylorassociates.com)*

### SIDE BEAM BRACKET #120

- 3/8" through 3/4" rod size
- Carbon Steel
- Bare Metal
- Complies with MSS SP-58 and SP-69 (Type 34).
- Designed to be fastened to side of joist in order to support a hanger rod.
- Specify rod size, figure number, name and finish
- Also available in Electro-Plated Zinc, Stainless Steel, and Hot Dipped Galvanized

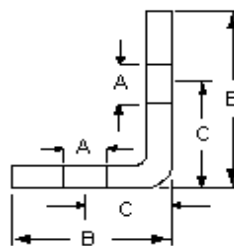

SIZE	SPECIFICATION DATA			MATERIAL	RECOM. MAX. LOAD (LBS)	APP'X WT. PER 100 (LBS)	PC'S PER PKG.
	Hole Size A	B	C				
3/8	7/16	2 1/16	1 5/16	3/16 x 1 1/2	300	23	100
1/2	9/16	2 1/8	1 3/8	1/4 x 1 1/2	560	33	100
5/8	11/16	2 3/4	1 5/8	3/8 x 2 1/2	900	113	50
3/4	13/16	3 1/4	2 3/16	3/8 x 2 1/2	900	139	50



QWI 4.3.1 Issue Date Mar/12 Rev.5

*Note: when referencing a printed copy of this specification page please insure it is the latest version as found on our website at [www.taylorassociates.com](http://www.taylorassociates.com)*

**CONCRETE CLEVIS PLATE #166**

(Complete with bolt and nut)

- 3/8" through 1 3/4" Rod
- Carbon Steel
- Bare Metal
- Structural attachment to concrete ceiling where flexibility is desired.
- Specify rod size, figure number, name and finish.
- Also available in Electro-Plated Zinc

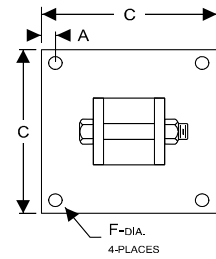
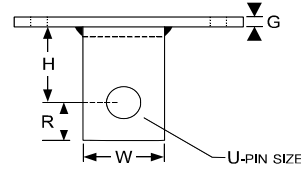
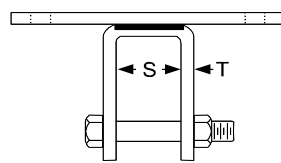

ROD SIZE	SPECIFICATION DATA								MAX. REC. LOAD (LBS)	APP'X WT. PER 100 (LBS)
	A	C	F	G	H	R	T	S		
3/8	1	10	9/16	3/8	2	7/8	1/4	1 1/4	730	1180
1/2	1	10	9/16	3/8	2	7/8	1/4	1 1/4	1350	1190
5/8	1	10	9/16	1/2	2	7/8	1/4	1 1/4	2160	1570
3/4	1	10	11/16	1/2	2	1 1/8	3/8	1 7/8	3230	1690
7/8	1	10	11/16	1/2	3	1 1/4	3/8	2	4480	1810
1	2	12	13/16	3/4	3	1 1/2	1/2	2 3/4	5900	3690
1 1/4	2	12	15/16	3/4	3	2	5/8	3	9500	4090
1 1/2	2	12	1 1/8	1	4	2 1/2	3/4	3 1/2	13800	5980
1 3/4	2	14	1 3/8	1 1/4	5	2 3/4	3/4	3 3/4	18600	9360



QWI 4.3.1 Issue Date June/15 Rev.5

*Note: when referencing a printed copy of this specification page please insure it is the latest version as found on our website at [www.taylorassociates.com](http://www.taylorassociates.com)*

### CONCRETE CLEVIS PLATE #167

- 3/8" through 1 3/4" Rod
- Carbon Steel
- Bare Metal
- Structural attachment to concrete ceiling where flexibility is desired.
- Specify rod size, figure number, name and finish.
- Also available in Electro-Plated Zinc

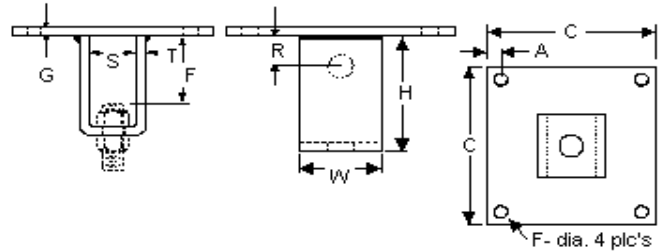

ROD SIZE	SPECIFICATION DATA								MAX.	APP'X WT.
	A	C	F	G	H	R	T	S	REC. LOAD (LBS)	PER 100 (LBS)
3/8	1	10	9/16	3/8	2	7/8	1/4	1 1/4	730	1180
1/2	1	10	9/16	3/8	2	7/8	1/4	1 1/4	1350	1190
5/8	1	10	9/16	1/2	2	7/8	1/4	1 1/4	2160	1570
3/4	1	10	11/16	1/2	2	1 1/8	3/8	1 7/8	3230	1690
7/8	1	10	11/16	1/2	3	1 1/4	3/8	2	4480	1810
1	2	12	13/16	3/4	3	1 1/2	1/2	2 3/4	5900	3690
1 1/4	2	12	15/16	3/4	3	2	5/8	3	9500	4090
1 1/2	2	12	1 1/8	1	4	2 1/2	3/4	3 1/2	13800	5980
1 3/4	2	14	1 3/8	1 1/4	5	2 3/4	3/4	3 3/4	18600	9360



QWI 4.3.1 Issue Date June/15 Rev.7

*Note: when referencing a printed copy of this specification page please insure it is the latest version as found on our website at [www.taylorassociates.com](http://www.taylorassociates.com)*



## U-BOLT - (Standard Duty) Bare Metal #14

- 1/2" through 36"
- Carbon Steel
- Bare Metal
- Complies with MSS SP-58 and SP-69 (Type 24).
- Designed as a support, guide, or anchor for heavy loads.
- Specify pipe size, figure number, name and finish.

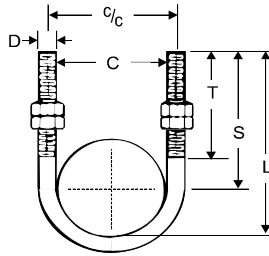

IRON PIPE SIZE	SPECIFICATION DATA						RECOM. LOAD 650°F	RECOM. LOAD 750°F	APP'X WT. PER 100 (LBS)	PC'S PER PKG.
	D	C	c/c	S	T	L				
1/2	3/8	15/16	1 5/16	2 3/8	2	2 3/4	1460	1144	23	100
3/4	3/8	1 1/8	1 1/2	2 1/2	2	3	1460	1144	24	100
1	3/8	1 3/8	1 3/4	2 5/16	2	3	1460	1144	25	100
1 1/4	3/8	1 11/16	2 1/16	2 15/16	2 1/4	3 3/4	1460	1144	26	100
1 1/2	3/8	2	2 3/8	3	2 1/2	3 15/16	1460	1144	28	100
2	3/8	2 7/16	2 13/16	3 5/16	2 1/2	4 1/2	1460	1144	32	100
2 1/2	1/2	2 15/16	3 7/16	3 13/16	3	5 1/4	2700	2114	70	50
3	1/2	3 9/16	4 1/16	4	3	5 3/4	2700	2114	76	50
3 1/2	1/2	4 1/16	4 9/16	4 1/4	3	6 1/4	2700	2114	80	50
4	1/2	4 9/16	5 1/16	4 1/2	3	6 3/4	2700	2114	86	50
5	1/2	5 5/8	6 1/8	5	3	7 7/8	2700	2114	100	25
6	5/8	6 3/4	7 3/8	6 3/16	3 3/4	9 1/2	4320	3382	198	25
8	5/8	8 3/4	9 3/8	7 7/16	3 7/8	11 3/4	4320	3382	226	10
10	3/4	10 7/8	11 5/8	8 3/8	4	13 3/4	6460	5060	394	10
12	7/8	12 7/8	13 3/4	9 5/8	4 1/4	16	8960	7016	640	10
14	7/8	14 1/8	15	10 1/4	4 7/8	17 1/4	8960	7016	830	BULK
16	7/8	16 1/8	17	11 1/4	4 7/8	19 1/4	8960	7016	920	BULK
18	1	18 1/8	19 1/8	12 3/4	4 7/8	21 3/4	11800	9240	1067	BULK
20	1	20 1/8	21 1/8	13 3/4	4 7/8	23 3/4	11800	9240	1474	BULK
24	1	24 1/8	25 1/8	15 1/2	4 7/8	27 1/2	11800	9240	1708	BULK
28	1	28 1/8	29 1/8	17 5/8	4 7/8	31 5/8	11800	9240	1800	BULK
30	1	30 1/8	31 1/8	18 5/8	4 7/8	33 5/8	11800	9240	1910	BULK
36	1	36 1/8	37 1/8	21 5/8	4 7/8	39 5/8	11800	9240	2260	BULK



QWI 4.3.1 Issue Date May/16 Rev.14

*Note: when referencing a printed copy of this specification page please insure it is the latest version as found on our website at [www.taylorassociates.com](http://www.taylorassociates.com)*

## U-BOLT - (Standard Duty) Zinc Plated #14Z

- 1/2" through 36"
- Carbon Steel
- Zinc Plated
- Complies with MSS SP-58 and SP-69 (Type 24).
- Designed as a support, guide, or anchor for heavy loads.
- Specify pipe size, figure number, name and finish.
- Also available in Stainless Steel, Hot Dipped Galvanized

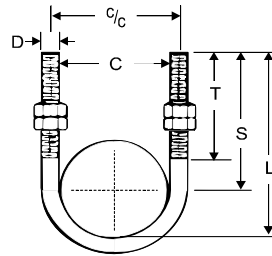

IRON PIPE SIZE	SPECIFICATION DATA						RECOM. LOAD 650°F	RECOM. LOAD 750°F	APP'X WT. PER 100 (LBS)	PC'S PER PKG.
	D	C	c/c	S	T	L				
1/2	1/4	15/16	1 3/16	2 3/4	2 3/8	3 1/8	580	454	11	100
3/4	1/4	1 1/8	1 3/8	2 3/4	2 3/8	3 1/4	580	454	12	100
1	1/4	1 3/8	1 5/8	2 3/4	2 3/8	3 3/8	580	454	12	100
1 1/4	3/8	1 11/16	2 1/16	2 15/16	2 1/4	3 3/4	1460	1144	28	100
1 1/2	3/8	2	2 3/8	3	2 1/2	3 15/16	1460	1144	29	100
2	3/8	2 7/16	2 13/16	3 5/16	2 1/2	4 1/2	1460	1144	32	100
2 1/2	1/2	2 15/16	3 7/16	3 13/16	3	5 1/4	2700	2114	68	50
3	1/2	3 9/16	4 1/16	4	3	5 3/4	2700	2114	77	50
3 1/2	1/2	4 1/16	4 9/16	4 1/4	3	6 1/4	2700	2114	82	50
4	1/2	4 9/16	5 1/16	4 1/2	3	6 3/4	2700	2114	88	50
5	1/2	5 5/8	6 1/8	5	3	7 7/8	2700	2114	93	25
6	5/8	6 3/4	7 3/8	6 3/16	3 3/4	9 1/8	4320	3382	194	25
8	5/8	8 3/4	9 3/8	7 7/16	3 7/8	11 3/4	4320	3382	236	10
10	3/4	10 7/8	11 5/8	8 3/8	4	13 3/4	6460	5060	489	10
12	7/8	12 7/8	13 3/4	9 5/8	4 1/4	16	8960	7016	776	10
14	7/8	14 1/8	15	10 1/4	4 7/8	17 1/4	8960	7016	832	BULK
16	7/8	16 1/8	17	11 1/4	4 7/8	19 1/4	8960	7016	919	BULK
18	1	18 1/8	19 1/8	12 3/4	4 7/8	21 3/4	11800	9240	1067	BULK
20	1	20 1/8	21 1/8	13 3/4	4 7/8	23 3/4	11800	9240	1474	BULK
24	1	24 1/8	25 1/8	15 1/2	4 7/8	27 1/2	11800	9240	1708	BULK
28	1	28 1/8	29 1/8	17 5/8	4 7/8	31 5/8	11800	9240	1800	BULK
30	1	30 1/8	31 1/8	18 5/8	4 7/8	33 5/8	11800	9240	1910	BULK
36	1	36 1/8	37 1/8	21 5/8	4 7/8	39 5/8	11800	9240	2260	BULK



QWI 4.3.1 Issue Date May/16 Rev.8

*Note: when referencing a printed copy of this specification page please insure it is the latest version as found on our website at [www.taylorassociates.com](http://www.taylorassociates.com)*

**HEX. NUTS - Zinc #15Z**

- 3/8" through 3/4"
- Carbon Steel Grade 2
- Zinc Plated
- Specify size, figure number, and name.



SIZE	PKG. QTY.	APPROX. WT. Per 100 PCS
3/8-16	100	2
1/2-13	100	4
5/8-11	50	7
3/4-10	50	12



QWI 4.3.1 Issue Date Feb/08 Rev.0

*Note: when referencing a printed copy of this specification page please insure it is the latest version as found on our website at [www.taylorassociates.com](http://www.taylorassociates.com)*

## 20° SWIVEL ROD EXTENSION #17W

- 3/8"
- Carbon Steel
- Electro-Zinc Plated
- The extension piece, when installed in the hanger assembly, allows for movement up to 20°. Threading at both ends is 3/8"-16 for use with standard threaded rod or hardware. Height adjustable with an inspection hole in collar to check the screw in depth of the threaded rod. Assemblies will hang "plumb" from the pivot point or, where movement is required, the hanging assembly will accommodate.
- Specify size, figure number, and name.

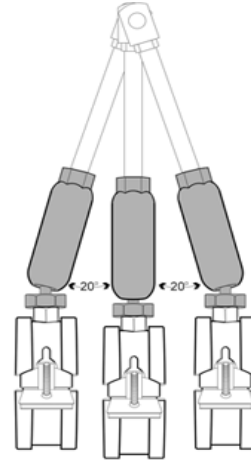

SIZE	BOX QTY.	APPROX. WT. Per 100 PCS	MAX LOAD
3/8"	25	9	600#



QWI 4.3.1 Issue Date Feb/08 Rev.0

*Note: when referencing a printed copy of this specification page please insure it is the latest version as found on our website at [www.taylorassociates.com](http://www.taylorassociates.com)*

### ROD WITH EYE #53

- 2 3/4" through 5"
- Carbon Steel
- A large diameter rod with eye end for load ratings through 184,000 pounds.
- Specify rod size, figure number, name, finish and "L" dimension. Indicate if desired thread length is other than standard.
- Also available in Galvanized

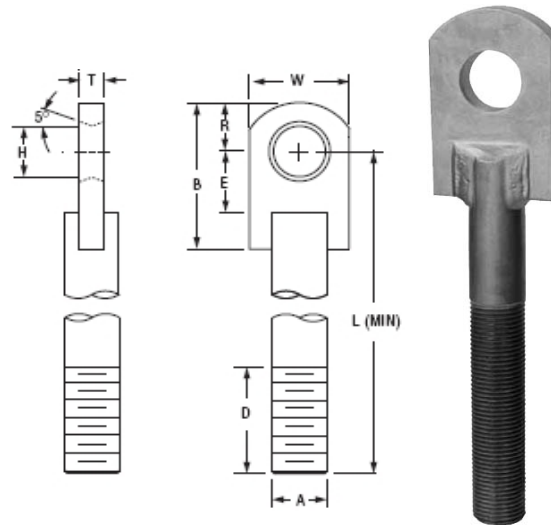

ROD SIZE A	SPECIFICATION DATA								MAX. LOAD		WT.* MIN. LENGTH	WT/Ft Additional LENGTH
	B	D	E	H	L (MIN)	R	T	W	650° F	750° F		
2 3/4	9 5/8	12	3 3/4	3 1/8	19	3 5/8	1 1/2	6	49400	38687	36	20
3	11	12	4	3 3/8	20	4	1 1/2	6	60100	47066	43	24
3 1/4	12 1/4	12	4	3 5/8	21	4 1/4	1 1/2	7	71900	56307	55	28
3 1/2	12 1/2	15	4 3/4	3 7/8	24	4 1/2	2	7	84700	66331	67	33
3 3/4	13 7/8	15	5	4 1/8	25	4 7/8	2	7 1/2	98500	77139	80	37
4	15 1/8	15	5	4 3/8	26	5 1/8	2	8 1/2	113400	88807	97	43
4 1/4	16 1/4	18	5 1/4	4 5/8	30	5 1/2	2	9 1/2	129400	101337	127	48
4 1/2	16	18	5 3/4	4 7/8	30	5 3/4	2 1/2	8 1/2	146600	114807	131	54
4 3/4	17	18	5 3/4	5 1/8	31	6	2 1/2	9 1/2	164700	128982	154	60
5	17 7/8	18	6 1/4	5 3/8	32	6 3/8	2 1/2	10	184000	144096	175	67

\*Weight calculated with minimum "L" for standard thread • Furnished with 4 UN series threads



QWI 4.3.1 Issue Date Mar/13 Rev.0

*Note: when referencing a printed copy of this specification page please insure it is the latest version as found on our website at [www.taylorassociates.com](http://www.taylorassociates.com)*

### ALL THREADED ROD #54

- 3/8"-16 x 10' through 1 1/2"-6 x 10'
- \*Mild Steel - Grade 2
- Zinc Plated
- Used in attaching hangers to structural attachments.
- Specify thread size, length, figure number, name and finish.
- Also available in Bare, Stainless Steel, and Hot Dipped Galvanized



\* Base material is C1008-C1020, conforming to the requirements of ASTM A307 Grade A spec, class 2 thread.

THREAD SIZE	SPECIFICATION DATA		LBS. WEIGHT PER FOOT	MAX. SAFE LOAD (LBS) ROD TEMPERATURE, 650°	MAX. SAFE LOAD (LBS) ROD TEMPERATURE, 750°
	BUNDLE QUANTITIES				
	MASTER	INNER			
1/4" - 20	500 PCS	25 PCS	0.12	240	--
3/8" - 16	300 PCS	15 PCS	0.29	730	572
1/2" - 13	200 PCS	10 PCS	0.53	1350	1057
5/8" - 11	100 PCS	5 PCS	0.84	2160	1692
3/4" - 10	100 PCS	5 PCS	1.22	3230	2530
7/8" - 9	60 PCS	3 PCS	1.69	4480	3508
1" - 8	60 PCS	3 PCS	2.23	5900	4620
1 1/4" - 7	1	1	3.56	9500	7440
1 1/2" - 6	1	1	5.15	13800	10807

**Note:** Other thread sizes and lengths available upon request



QWI 4.3.1 Issue Date June/14 Rev.3

*Note: when referencing a printed copy of this specification page please insure it is the latest version as found on our website at [www.taylorassociates.com](http://www.taylorassociates.com)*

**HANGER ROD - Right-hand Threads #57**  
**HANGER ROD - Right and Left hand Threads #58**

- 3/8" through 5"
- Carbon Steel
- Bare Metal
- Specify rod size, figure number, name, rod length and finish.  
Specify thread length if other than standard.
- Also available in Electro-Plated Zinc, Stainless Steel, and Hot Dipped Galvanized\*.

**Note:** The acceptability of galvanized coating at temperatures above 450°F is at the discretion of the end user.

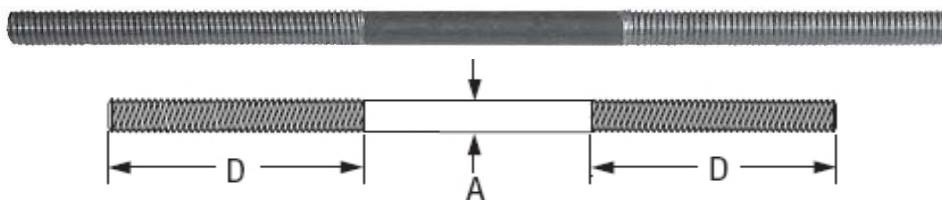

ROD SIZE A	Threads per Inch	Max. Load		Standard Rod Thread Length D
		650° F	750° F	
3/8	16	730	572	2 1/2
1/2	13	1350	1057	2 1/2
5/8	11	2160	1692	2 1/2
3/4	10	3230	2530	3
7/8	9	4480	3508	3 1/2
1	8	5900	4620	4
1 1/4	7	9500	7440	5
1 1/2	6	13800	10807	6
1 3/4	5	18600	14566	7
2	4 1/2	24600	19265	8
2 1/4	4 1/2	32300	25295	9
2 1/2	4	39800	31169	10
2 3/4	4	49400	38687	11
3	4	60100	47066	12
3 1/4	4	71900	56307	13
3 1/2	4	84700	66331	14
3 3/4	4	98500	77139	15
4	4	113400	88807	15
4 1/4	4 UN	129400	101337	18
4 1/2	4 UN	146600	114807	18
4 3/4	4 UN	164700	128982	18
5	4 UN	184000	144096	18

**3/8"-4" Diameter: UNC-2A CLASS fit.**



QWI 4.3.1 Issue Date Jan/16 Rev.1

*Note: when referencing a printed copy of this specification page please insure it is the latest version as found on our website at [www.taylorassociates.com](http://www.taylorassociates.com)*

**WOOD DRIVE SCREW #59**

- 12 through 16
- Carbon Steel
- Bare Metal
- Designed for fastening attachments to wood beams.
- Specify size and figure number.



SIZE	LENGTH	APPROX. WT. Per 100 PCS	PKG. QTY
12	1 1/2	1.40	100
14	1 1/2	1.60	100
16	2	2.50	100



QWI 4.3.1 Issue Date Mar/09 Rev.1

*Note: when referencing a printed copy of this specification page please insure it is the latest version as found on our website at [www.taylorassociates.com](http://www.taylorassociates.com)*



### COACH SCREW ROD - Socket Drive #60WZ

- 3" through 12"
- Carbon Steel
- Electro-Zinc Plated
- Coach screw rod with a Torx head cavity for smooth and easy installation. Hex pattern in the middle of the screw allows for adjustment with a wrench.
- Specify size, figure number, and name.

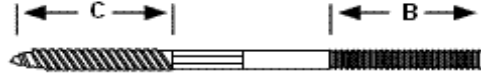

SIZE	Dim.B	Dim.C	BOX QTY.	APPROX. WT. Per 100 PCS
3/8" X 3"	1 1/8"	1 3/8"	50	6
3/8" X 5"	1 1/2"	2 3/8"	50	11
3/8" X 8"	2 1/2"	3"	50	16
3/8" X 10"	2 1/2"	3"	10	20
3/8" X 12"	2 1/2"	3"	10	24



QWI 4.3.1 Issue Date Aug/09 Rev.2

*Note: when referencing a printed copy of this specification page please insure it is the latest version as found on our website at [www.taylorassociates.com](http://www.taylorassociates.com)*

**ROD COUPLING #62  
with Sight Hole #62S**

- 3/8" through 1 1/2" rod
- Carbon Steel
- Electro-plated zinc
- Designed for coupling two hanger rods of equal rod size
- Specify rod size, figure number and name.
- Also available in Stainless Steel, Hot Dipped Galvanized, Bare Metal

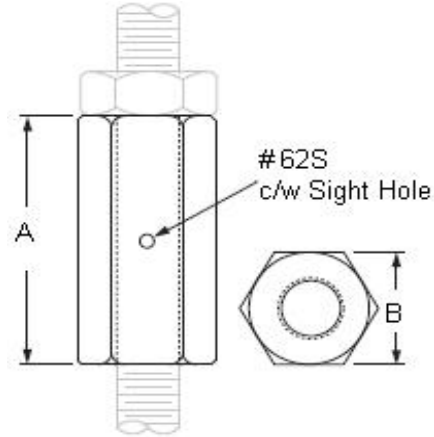

ROD SIZE	SPECIFICATION DATA		RECOM. MAX. LOAD (LBS)	APP'X WT. PER 100 (LBS)	PC'S PER PKG.
	A	B			
3/8	1 3/4	9/16	730	11	100
1/2	1 3/4	11/16	1350	10	50
5/8	2 1/8	13/16	2160	18	25
3/4	2 1/4	1	3230	28	25
7/8	2 1/2	1 1/4	4480	58	-
1	2 1/2	1 1/4	5900	46	-
1 1/4	3	1 5/8	6660	140	-
1 1/2	4	2	7000	196	-

**Note:** Reducing Rod Couplings are also available upon request



QWI 4.3.1 Issue Date Mar/13 Rev.4

*Note: when referencing a printed copy of this specification page please insure it is the latest version as found on our website at [www.taylorassociates.com](http://www.taylorassociates.com)*

## FORGED STEEL CLEVIS #63

- 3/8" through 4" rod size
- Forged Steel
- Bare Metal
- Complies with MSS SP-58 and SP-69 (Type 14).
- Designed for use on high temperature piping installations
- Specify figure number, name, size, pin size.
- Also available in Hot Dipped Galvanized, and Stainless Steel

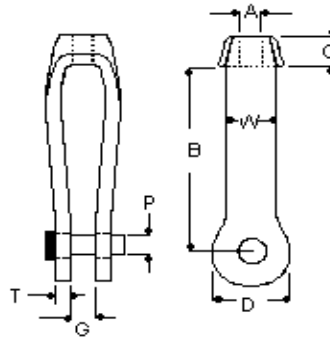

SIZE A	CLEVIS SIZE NO.	SPECIFICATION DATA							WGT. EACH (LBS)	MAX REC LOAD (LBS)	
		B	C	D	G GRIP	P PIN DIA.	T	W		650°	750°
3/8	2	3 9/16	5/8	1 7/16	1/2	1/2	5/16	1 1/16	1.0	730	572
1/2	2	3 9/16	5/8	1 7/16	1/2	5/8	5/16	1 1/16	1.0	1350	1055
5/8	2	3 9/16	5/8	1 7/16	5/8	3/4	5/16	1 1/16	1.1	2160	1690
3/4	2 1/2	4	1	2 1/2	3/4	7/8	5/16	1 1/4	2.3	3230	2530
7/8	2 1/2	4	1	2 1/2	7/8	1	5/16	1 1/4	2.5	4480	3508
1	3	5 1/16	1 1/4	3	1	1 1/8	1/2	1 1/2	5.1	5900	4620
1 1/4	3	5 1/16	1 1/4	3	1 1/4	1 3/8	1/2	1 1/2	5.6	9500	7440
1 1/2	3 1/2	6	1 1/2	3 1/2	1 1/2	1 5/8	1/2	1 3/4	8.1	13800	10807
1 3/4	4	6	1 3/4	4	1 1/2	1 7/8	1/2	2	12.9	18600	14566
2	5	7	2 1/4	5	2 1/2	2 1/4	5/8	2 1/2	23	24600	19265
2 1/4	6	8	2 3/4	6	2 1/2	2 1/2	3/4	3	35	32300	25295
2 1/2	6	8	2 3/4	6	2 1/2	2 3/4	3/4	3	36	39800	31169
2 3/4	7	9	3	7	2 1/2	3	7/8	3 1/2	50	49400	38680
3	7	9	3	7	2 1/2	3 1/4	7/8	3 1/2	51	60100	47066
3 1/4 *	8	10	4	8	4	3 1/2	1 1/2	4	116	71900	56300
3 1/2 *	8	10	4	8	4	3 3/4	1 1/2	4	118	84700	66330
3 3/4 *	8	10	4	8	4	4	1 1/2	4	120	98500	77139
4 *	8	10	4	8	4	4 1/4	1 1/2	4	122	113400	88805

\* Furnished with 4UN Threads



QWI 4.3.1 Issue Date Feb/13 Rev.7

Note: when referencing a printed copy of this specification page please insure it is the latest version as found on our website at [www.taylorassociates.com](http://www.taylorassociates.com)

## WELDLESS EYE NUT #64

- 3/8" through 2 1/2" rod size
- Forged Steel
- Bare Metal
- Complies with MSS SP-58 and SP-69 (Type 17).
- Designed for use on high temperature piping applications.
- Specify rod size, figure number, name and finish.
- Also available in Electro-Plated Zinc, Hot Dipped Galvanized, and Stainless Steel



### WARNING

RATED CAPACITY IS DRAMATICALLY REDUCED WHEN LOADED AT ANY ANGLE. LOADING MUST NEVER BE MADE AT AN ANGLE GREATER THAN 45° FROM BOLT CENTERLINE.

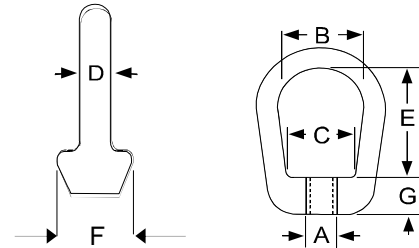

ROD SIZE	SPECIFICATION DATA						RECOM. MAX. LOAD (LBS) 650°	RECOM. MAX. LOAD (LBS) 750°	APP'X WT. PER 100 (LBS)
	A	B	C	D	E	F	G		
3/8	1 1/2	1 3/16	1/2	2	1 3/8	11/16	730	570	66
1/2	1 1/2	1 3/16	1/2	2	1 3/8	11/16	1350	1050	66
5/8	1 1/2	1 3/16	1/2	2	1 3/8	11/16	2160	1692	65
3/4	1 1/2	1 3/16	1/2	2	1 3/8	11/16	3230	2530	58
7/8	2	1 13/16	3/4	2 3/8	1 15/16	1	4480	3508	162
1	2	1 13/16	3/4	2 3/8	1 15/16	1	5900	4620	159
1 1/4	2 1/2	1 13/16	1	3 3/8	2 3/8	1 1/4	9500	7740	350
1 1/2	2 1/2	1 13/16	1	3 3/8	2 3/8	1 1/4	13800	10800	350
1 3/4	4	4	1 1/2	6 1/4	4	2 1/4	18600	14566	1640
2	4	4	1 1/2	6 1/4	4	2 1/4	24600	19265	1675
2 1/4	4	4	1 1/2	6 1/4	4	2 1/4	32300	25295	1675
2 1/2	4	4	1 1/2	6 1/4	4	2 1/4	39800	31169	1675



QWI 4.3.1 Issue Date May/13 Rev.7

*Note: when referencing a printed copy of this specification page please insure it is the latest version as found on our website at [www.taylorassociates.com](http://www.taylorassociates.com)*

## EYE SOCKET #65

- 1/4" through 7/8" rod size
- Malleable Iron
- Bare Metal
- Complies with MSS SP-58 and SP-69 (Type 16).
- A non-adjustable threaded rod attachment often used with the split ring hanger Fig. # 38R
- Specify rod size, figure number, name and finish.
- Also available in Electro-Plated Zinc

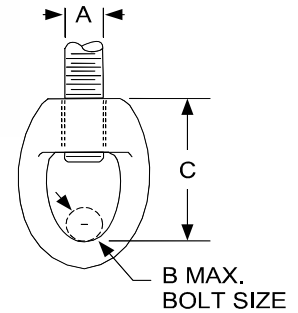

ROD SIZE A	SPECIFICATION DATA			RECOM. MAX. LOAD (LBS)	APP'X WT. PER 100 (LBS)	PIECES PER PACKAGE
	IRON PIPE SIZE	B	C			
1/4	3/8	1/4	1 11/32	230 *	5	100
3/8	1/2 - 2	1/4	1 11/32	610	7	100
1/2	2 1/2 - 3 1/2	1/4	1 17/32	1000	13	100
5/8	4 - 5	3/8	1 13/16	1400	19	50
3/4	6	1/2	2 5/32	2200	31	50
7/8	8	1/2	2 11/32	2300	44	50



\* Based on recommended maximum load for 1/4" threaded rod

QWI 4.3.1 Issue Date Aug/12 Rev.6

*Note: when referencing a printed copy of this specification page please insure it is the latest version as found on our website at [www.taylorassociates.com](http://www.taylorassociates.com)*

**TURNBUCKLE #68**

- 3/8" through 2 1/2" rod size
- Forged Steel
- Bare Metal
- Complies with MSS SP-58 and SP-69 (Type 13).
- Designed as an adjustable hanger rod connection.
- Specify rod size, figure number, name and finish.
- Also available in Electro-Plated Zinc, Stainless Steel, and Hot Dipped Galvanized
- Tapped right hand and left hand thread.
- Larger rod size available upon request.
- Different openings available upon request.



ROD SIZE D	SPECIFICATION DATA		RECOM. MAX. LOAD (LBS) @ 650° F	APPROX. WT per 100 6" Opening
	A			
3/8	6		730	42
1/2	6		1350	65
5/8	6		2160	98
3/4	6		3230	145
7/8	6		4480	185
1	6		5900	260
1 1/4	6		9500	445
1 1/2	6		13800	640
1 3/4	6		18600	1100
2	6		24600	1490
2 1/4	6		32300	1960
2 1/2	6		39800	2690



QWI 4.3.1 Issue Date Feb/13 Rev.4

*Note: when referencing a printed copy of this specification page please insure it is the latest version as found on our website at [www.taylorassociates.com](http://www.taylorassociates.com)*

### TURNBUCKLE ADJUSTER #114

- 3/8" through 1/2"
- Malleable Iron
- Bare Metal, copper plated.
- Designed to provide vertical rod adjustment with split ring hanger.
- Complies with MSS SP-58 and SP-69 (Type 15).
- Specify rod size, name, finish

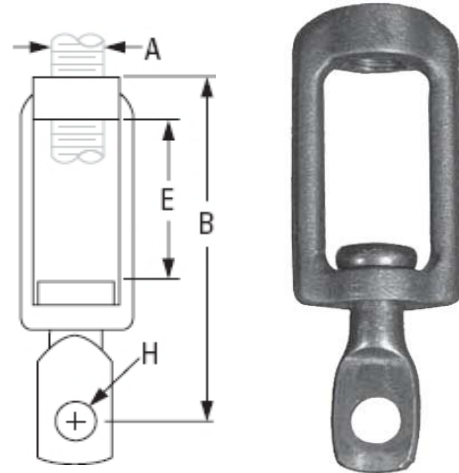

ROD SIZE A	PIPE SIZE	SPECIFICATION DATA			MAX. REC. LOAD (Lbs.)	WEIGHT EACH (LBS)
		B	E	H		
3/8-16	1/2 - 2	4.300	2	0.410	730	0.30
1/2-13	2 1/2 - 3 1/2	4.300	2	0.410	730	0.28



QWI 4.3.1 Issue Date Apr/13 Rev.0

*Note: when referencing a printed copy of this specification page please insure it is the latest version as found on our website at [www.taylorassociates.com](http://www.taylorassociates.com)*

### EXTENSION PIECE #411

- 3/8" through 7/8" rod size
- Malleable Iron
- Bare Metal
- Designed for attaching a hanger rod to various building attachments.
- Specify rod size, figure number, name and finish.
- Also available in Electro-Plated Zinc

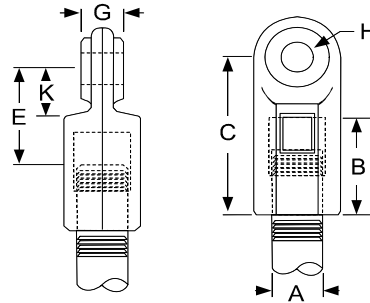

ROD SIZE	IRON PIPE SIZE	SPECIFICATION DATA						RECOM.	APP'X WT.
		B	C	E	G	H	K	MAX. LOAD (LBS.)	PER 100 (LBS.)
<b>3/8</b>	3/4 - 2	1 5/16	2 1/16	1 3/16	1/2	1/2	9/16	610	19
<b>1/2</b>	2 1/2 - 3 1/2	1 7/16	2 5/16	1 5/16	5/8	1/2	11/16	1130	41
<b>5/8</b>	4 - 5	1 9/16	2 7/16	1 7/16	5/8	1/2	3/4	1810	42
<b>3/4</b>	6	1 7/8	2 7/8	1 9/16	5/8	1/2	7/8	2710	68
<b>7/8</b>	8 - 12	2	3 1/16	1 11/16	3/4	9/16	7/8	2950	78



QWI 4.3.1 Issue Date Mar/12 Rev.4

*Note: when referencing a printed copy of this specification page please insure it is the latest version as found on our website at [www.taylorassociates.com](http://www.taylorassociates.com)*



**PIPE COVERING PROTECTION SHIELD #69**



- Sizes 0 through 30 (see table below)
- Pre-Galvanized Carbon Steel
- Designed for outside of foam or fiberglass insulation on stationary pipe lines to prevent crushing of insulation without breaking the vapor barrier.
- Specify shield size, figure number, name and finish
- Also available in Stainless Steel, and Hot Dipped Galvanized

SHIELD SIZE	SPECIFICATION DATA			MATERIAL	APPROX. WEIGHT PER 100
	SHIELD I.D.	HANGER SIZE	LENGTH		
0	1 7/8	1 1/2	12"	18 ga.	51
1	2 3/8	2	12"	18 ga.	63
2	2 7/8	2 1/2	12"	18 ga.	77
3	3 1/2	3	12"	18 ga.	90
4	4	3 1/2	12"	18 ga.	95
5	4 1/2	4	12"	18 ga.	110
6	5	5	12"	18 ga.	125
7	5 9/16	5	12"	18 ga.	140
8	6 5/8	6	12"	18 ga.	165
9	7 5/8	8	12"	18 ga.	190
10	8 5/8	8	12"	18 ga.	210
13	9 5/8	10	12"	18 ga.	235
14	10 3/4	10	12"	18 ga.	265
15	11 3/4	12	12"	18 ga.	295
16	12 3/4	12	12"	18 ga.	315
17	14	14	12"	16 ga.	445
18	15	16	12"	16 ga.	446
19	16	16	12"	16 ga.	490
20	17	18	12"	16 ga.	515
21	18	18	12"	16 ga.	550
22	19	20	12"	16 ga.	570
23	20	20	12"	16 ga.	635
24	21	24	12"	16 ga.	645
25	22	24	12"	16 ga.	660
26	23	24	12"	16 ga.	700
27	24	24	12"	16 ga.	785
28	26	30	12"	16 ga.	790
29	27	30	12"	16 ga.	805
30	28	30	12"	16 ga.	860

PIPE SIZE	Insulation Thickness				
	1/2	3/4	1	1 1/2	2
1/2	0	1	2	-	-
3/4	1	1	2	4	6
1	1	2	3	5	7
1 1/4	2	3	3	6	7
1 1/2	2	3	4	6	8
2	3	4	5	7	8
2 1/2	4	5	6	7	8
3	5	6	7	8	9
3 1/2	-	-	8	9	10
4	-	-	8	9	10
5	-	-	9	10	13
6	-	-	10	13	14
8	-	-	14	15	16
10	-	-	16	17	18
12	-	-	18	19	20
14	-	-	19	20	21
16	-	-	21	22	23
18	-	-	23	24	25
20	-	-	25	26	27
24	-	-	28	29	30

TUBING SIZE	Insulation Thickness				
	1/2	3/4	1	1 1/2	2
1/2	0	1	2	4	5
3/4	0	1	2	4	6
1	1	2	3	4	6
1 1/4	1	2	3	5	7
1 1/2	2	3	3	5	8
2	3	4	4	6	8
2 1/2	4	5	5	7	8
3	5	6	6	8	9
3 1/2	6	7	7	8	9
4	7	7	8	9	10
5	8	8	9	10	13
6	9	9	10	13	14



QWI 4.3.1 Issue Date Sept/15 Rev.7

*Note: when referencing a printed copy of this specification page please insure it is the latest version as found on our website at [www.taylorassociates.com](http://www.taylorassociates.com)*

## HEAVY DUTY PIPE COVERING PROTECTION SHIELD #69H

- Sizes 0 through 30 (see table below)
- Pre-Galvanized Carbon Steel
- Designed for outside of foam or fiberglass insulation on stationary pipe lines to prevent crushing of insulation without breaking the vapor barrier.
- Complies with MSS SP-58 and SP-69 (Type 40)
- Specify shield size, figure number, name and finish
- Also available in Stainless Steel, and Hot Dipped Galvanized



SHIELD SIZE	SPECIFICATION DATA			MATERIAL	APPROX. WEIGHT PER 100
	SHIELD I.D.	HANGER SIZE	LENGTH		
0	1 7/8	1 1/2	12"	18 ga.	53
1	2 3/8	2	12"	18 ga.	68
2	2 7/8	2 1/2	12"	18 ga.	82
3	3 1/2	3	12"	18 ga.	102
4	4	3 1/2	12"	18 ga.	113
5	4 1/2	4	12"	18 ga.	126
6	5	5	12"	18 ga.	142
7	5 9/16	5	12"	18 ga.	158
8	6 5/8	6	12"	16 ga.	233
9	7 5/8	7	12"	16 ga.	266
10	8 5/8	8	12"	16 ga.	300
11	7 5/8	7	18"	16 ga.	399
12	8 5/8	8	18"	16 ga.	449
13	9 5/8	10	18"	16 ga.	503
14	10 3/4	10	18"	16 ga.	562
15	11 3/4	12	24"	14 ga.	1012
16	12 3/4	12	24"	14 ga.	1094
17	14	14	24"	14 ga.	1203
18	15	16	24"	14 ga.	1292
19	16	16	24"	14 ga.	1374
20	17	18	24"	14 ga.	1463
21	18	18	24"	12 ga.	2133
22	19	20	24"	12 ga.	2256
23	20	20	24"	12 ga.	2379
24	21	24	24"	12 ga.	2492
25	22	24	24"	12 ga.	2615
26	23	24	24"	12 ga.	2737
27	24	24	24"	12 ga.	2851
28	26	30	24"	12 ga.	3087
29	27	30	24"	12 ga.	3209
30	28	30	24"	12 ga.	3322

PIPE SIZE	Insulation Thickness				
	1/2	3/4	1	1 1/2	2
1/2	1	1	2	-	-
3/4	1	2	3	4	6
1	1	2	3	5	7
1 1/4	2	3	4	6	7
1 1/2	2	3	4	6	8
2	3	4	5	7	8
2 1/2	4	5	-	8	9
3	5	6	7	8	9
3 1/2	-	-	8	9	10
4	-	-	8	9	10
5	-	-	9/11	10/12	13
6	-	-	10/12	13	14
8	-	-	14	15	16
10	-	-	16	17	18
12	-	-	18	19	20
14	-	-	19	20	21
16	-	-	21	22	23
18	-	-	23	24	25
20	-	-	25	26	27
24	-	-	28	29	30

TUBING SIZE	Insulation Thickness				
	1/2	3/4	1	1 1/2	2
1/2	0	1	2	4	5
3/4	0	1	2	4	6
1	1	2	3	5	7
1 1/4	1	2	3	5	7
1 1/2	2	3	4	6	8
2	3	4	5	7	8
2 1/2	4	5	6	8	8
3	5	6	7	8	9
3 1/2	6	7	8	8	9/11
4	7	8	8	9	10/12
5	8	8	9	10	13
6	9	9	10	13	14

**TAYLOR**  
PIPE SUPPORTS

QWI 4.3.1 Issue Date Mar/12 Rev.6

Note: when referencing a printed copy of this specification page please insure it is the latest version as found on our website at [www.taylorassociates.com](http://www.taylorassociates.com)

### PIPE COVERING PROTECTION SADDLE #70 (1" Insulation)

- 3/4" through 14"
- Carbon Steel
- Bare Metal
- Complies with MSS SP-58 and MSS SP-69 (Type 39).
- Designed to protect pipe insulation from crushing, typically used on high temperature pipe lines.
- Specify pipe size, figure number, name and finish.
- Also available in Electro-Plated Zinc, Stainless Steel, and Hot Dipped Galvanized
  
- All saddles 12" in length.**
- Center rib starts at 12" IP**



IRON PIPE SIZE	SPECIFICATION DATA				ACTUAL THICKNESS OF COVERING	RECOM. MAX. LOAD (LBS.)	APP'X WT. PER 100 (LBS.)
	C	D	HANGER ROLLER SIZE				
			# 94/95	# 93			
3/4	1 9/16	1 15/16	2	2 1/2	7/8	1200	146
1	1 13/16	2 1/4	2 1/2	3	1 1/16	1200	146
1 1/4	1 15/16	2 1/2	2 1/2	3	7/8	1200	146
1 1/2	2 1/8	2 5/8	3	3 1/2	1	1200	150
2	2 7/16	3	3 1/2	4	1 1/16	1200	155
2 1/2	2 11/16	3 1/4	3 1/2	5	1 1/16	1200	155
3	2 15/16	3 1/2	4	5	1	1200	178
3 1/2	3 7/16	4	5	6	1 1/4	1200	199
4	3 9/16	4 3/16	5	6	1 1/16	1200	199
5	4 1/8	4 13/16	6	8	1	1200	199
6	4 9/16	5 3/8	8	8	1	1800	394
8	5 9/16	6 9/16	10	12	1	1800	478
10	6 5/8	8	12	14	1	1800	478
12	7 5/8	8 7/8	14	16	1 1/16	5000	750
14	8 11/16	10 1/16	16	18	1 1/16	5000	750



QWI 4.3.1 Issue Date Mar/12 Rev.7

*Note: when referencing a printed copy of this specification page please insure it is the latest version as found on our website at [www.taylorassociates.com](http://www.taylorassociates.com)*

### PIPE COVERING PROTECTION SADDLE #71 (1 1/2" Insulation)

- 3/4" through 20"
- Carbon Steel
- Bare Metal
- Complies with MSS SP-58 and MSS SP-69 (Type 39).
- Designed to protect pipe insulation from crushing, typically used on high temperature pipe lines.
- Specify pipe size, figure number, name and finish.
- Also available in Electro-Plated Zinc, Stainless Steel, and Hot Dipped Galvanized
  
- All saddles 12" in length.**
- Center rib starts at 12" IP**

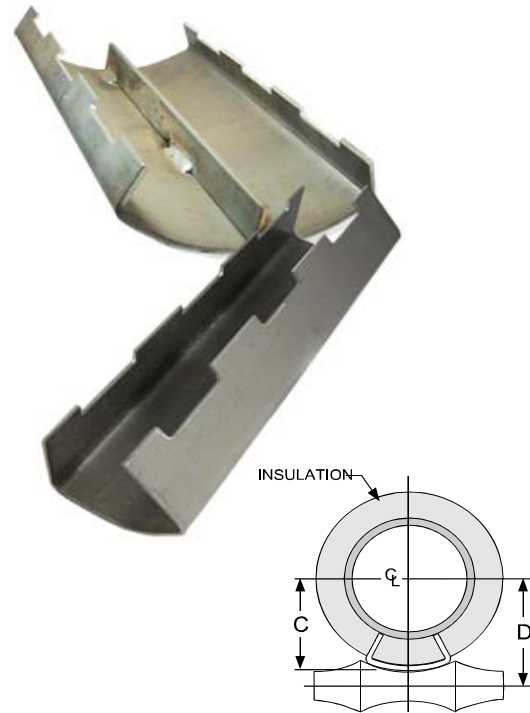

IRON PIPE SIZE	SPECIFICATION DATA				ACTUAL THICKNESS OF COVERING	RECOM. MAX. LOAD (LBS.)	APP'X WT. PER 100 (LBS.)
	C	D	HANGER ROLLER SIZE				
			# 94/95	# 93			
3/4	2 1/8	2 5/8	3	3 1/2	1 7/16	1200	199
1	2 7/16	2 15/16	3	4	1 9/16	1200	199
1 1/4	2 9/16	3 1/8	3 1/2	5	1 5/8	1200	199
1 1/2	2 11/16	3 1/4	3 1/2	5	1 1/2	1200	199
2	2 7/8	3 1/2	4	5	1 9/16	1200	220
2 1/2	3 3/4	4 1/8	5	6	1 7/8	1200	220
3	3 1/2	4 3/16	5	6	1 9/16	1200	220
3 1/2	4	4 11/16	6	8	1 13/16	1800	241
4	3 3/32	4 11/16	6	8	1 9/16	1800	241
5	4 1/2	5 5/16	8	8	1 1/2	1800	241
6	5 1/16	5 7/8	8	10	1 1/2	1800	458
8	6	7 1/8	10	12	1 1/2	1800	586
10	7 1/4	8 5/16	12	14	1 9/16	1800	586
12	8 1/16	9 5/8	14	16	1 1/2	5000	830
14	8 7/8	10 3/16	16	18	1 1/2	5000	830
16	9 7/8	11 3/8	18	20	1 1/2	5000	926
18	10 7/8	12 1/2	20	--	1 1/2	5000	990
20	11 3/4	13 11/16	24	--	1 1/2	7200	1054



QWI 4.3.1 Issue Date Mar/12 Rev.6

*Note: when referencing a printed copy of this specification page please insure it is the latest version as found on our website at [www.taylorassociates.com](http://www.taylorassociates.com)*

## PIPE COVERING PROTECTION SADDLE #72 (2" Insulation)

- 3/4" through 20"
- Carbon Steel
- Bare Metal
- Complies with MSS SP-58 and MSS SP-69 (Type 39).
- Designed to protect pipe insulation from crushing, typically used on high temperature pipe lines.
- Specify pipe size, figure number, name and finish.
- Also available in Electro-Plated Zinc, Stainless Steel, and Hot Dipped Galvanized

- All saddles 12" in length.
- Center rib starts at 12" IP

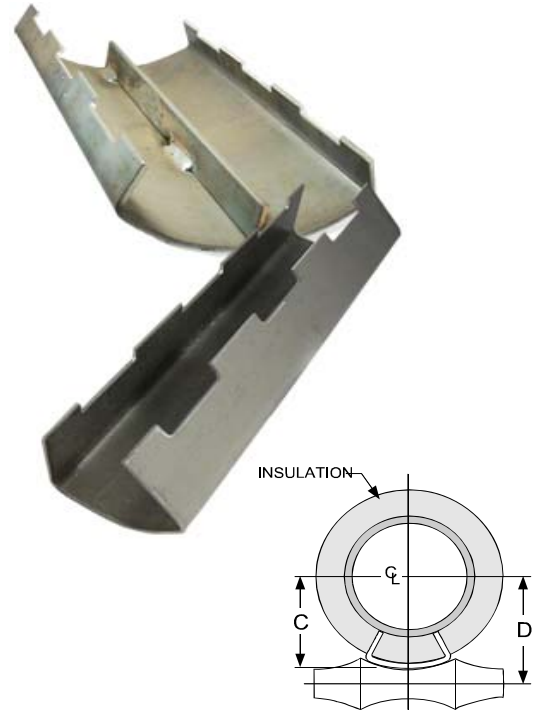

IRON PIPE SIZE	SPECIFICATION DATA				ACTUAL THICKNESS OF COVERING	RECOM. MAX. LOAD (LBS.)	APP'X WT. PER 100 (LBS.)
	C	D	HANGER ROLLER SIZE				
			# 94/95	# 93			
3/4	2 3/4	3 3/8	4	5	2 1/16	1200	263
1	2 7/8	3 1/2	4	5	2 1/8	1200	263
1 1/4	3 1/16	3 11/16	5	5	2 1/16	1200	263
1 1/2	3 7/16	4 1/8	5	6	2 5/16	1800	284
2	3 11/16	4 3/8	5	6	2 1/8	1800	284
2 1/2	3 15/16	4 5/8	6	8	2 5/16	1800	284
3	4 1/8	4 7/8	6	8	2 1/16	1800	328
3 1/2	4	5 3/16	8	8	2 1/4	1800	328
4	4 11/16	5 1/2	8	8	2 1/16	1800	328
5	4 15/16	5 7/8	8	10	2	1800	328
6	5 1/2	6 1/2	10	10	2	1800	586
8	6 1/2	7 5/8	12	12	2	1800	618
10	7 5/8	9 1/16	14	16	2 1/16	1800	618
12	8 13/16	10 3/16	16	18	2 1/16	5000	990
14	9 1/4	10 3/4	16	18	2	5000	990
16	10 1/4	11 7/8	18	20	2	5000	1054
18	11 1/2	13 1/16	20	--	2	7200	1118
20	12 5/16	14 1/4	24	--	2	7200	1181



QWI 4.3.1 Issue Date Mar/12 Rev.6

*Note: when referencing a printed copy of this specification page please insure it is the latest version as found on our website at [www.taylorassociates.com](http://www.taylorassociates.com)*

### PIPE COVERING PROTECTION SADDLE #73 (2 1/2" Insulation)

- 1 1/4" through 20"
- Carbon Steel
- Bare Metal
- Complies with MSS SP-58 and MSS SP-69 (Type 39).
- Designed to protect pipe insulation from crushing, typically used on high temperature pipe lines.
- Specify pipe size, figure number, name and finish.
- Also available in Electro-Plated Zinc, Stainless Steel, and Hot Dipped Galvanized
  
- **All saddles 12" in length.**
- **Center rib starts at 12" IP**

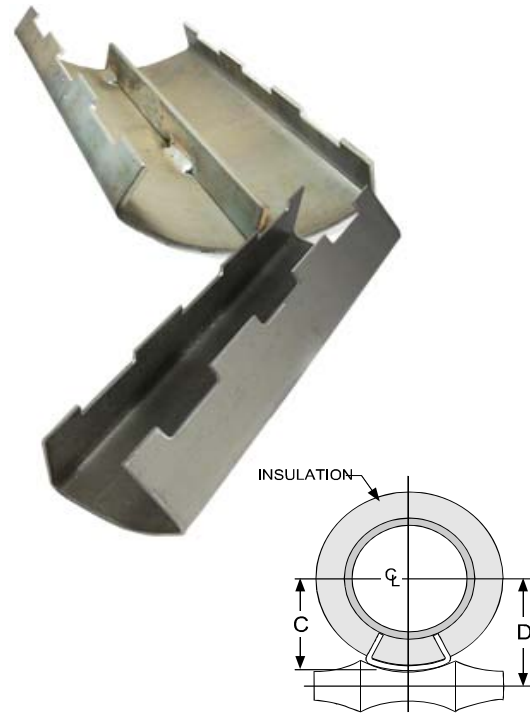

IRON PIPE SIZE	SPECIFICATION DATA				ACTUAL THICKNESS OF COVERING	RECOM. MAX. LOAD (LBS.)	APP'X WT. PER 100 (LBS.)
	C	D	HANGER ROLLER SIZE				
			# 94/95	# 93			
1 1/4	3 13/16	4 5/8	6	8	2 13/16	1800	326
2	3 15/16	4 3/4	6	8	2 5/8	1800	326
2 1/2	4 7/16	5 1/4	8	8	2 7/8	1800	348
3	4 11/16	5 3/8	8	8	2 9/16	1800	348
3 1/2	4 13/16	5 3/4	8	10	2 3/4	1800	369
4	5 1/8	6 1/16	8	10	2 9/16	1800	369
5	5 9/16	6 1/2	10	12	2 9/16	1800	369
6	6 1/16	7 1/16	10	12	2 1/2	1800	618
8	7 1/4	8 5/16	12	14	2 11/16	1800	682
10	8 3/16	9 5/8	14	16	2 9/16	1800	714
12	9 1/8	10 11/16	16	18	2 5/8	5000	1102
14	9 3/4	11 5/16	18	20	2 1/2	5000	1102
16	10 7/8	12 7/16	20	--	2 1/2	7200	1181
18	12	13 15/16	24	--	2 1/2	7200	1245
20	12 7/8	14 13/16	24	--	2 1/2	7200	1309



QWI 4.3.1 Issue Date Mar/12 Rev.6

*Note: when referencing a printed copy of this specification page please insure it is the latest version as found on our website at [www.taylorassociates.com](http://www.taylorassociates.com)*

### PIPE COVERING PROTECTION SADDLE #74 (3" Insulation)

- 2" through 20"
- Carbon Steel
- Bare Metal
- Complies with MSS SP-58 and MSS SP-69 (Type 39).
- Designed to protect pipe insulation from crushing, typically used on high temperature pipe lines.
- Specify pipe size, figure number, name and finish.
- Also available in Electro-Plated Zinc, Stainless Steel, and Hot Dipped Galvanized
  
- **All saddles 12" in length.**
- **Center rib starts at 12" IP**

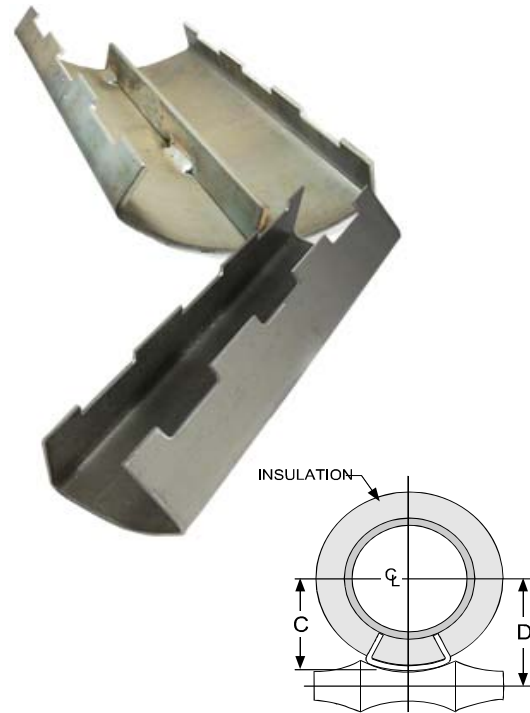

IRON PIPE SIZE	SPECIFICATION DATA				ACTUAL THICKNESS OF COVERING	RECOM. MAX. LOAD (LBS.)	APP'X WT. PER 100 (LBS.)
	C	D	HANGER ROLLER SIZE				
			# 94/95	# 93			
2	4 11/16	5 1/2	8	8	3 1/8	1800	390
2 1/2	4 15/16	5 3/4	8	10	3 3/8	1800	390
3	5	5 15/16	10	10	3 1/16	1800	433
3 1/2	5 1/2	6 7/16	10	10	3 5/16	1800	433
4	5 9/16	6 1/2	10	10	3 1/16	1800	433
5	6 1/8	7 1/16	10	12	3 1/16	1800	433
6	6 9/16	7 5/8	12	12	3	1800	809
8	7 5/8	9 1/8	14	16	3 1/8	1800	809
10	8 7/8	10 1/4	16	18	3 1/16	1800	873
12	9 11/16	11 5/16	18	20	3 1/16	5000	1229
14	10 1/4	11 7/8	18	20	3	5000	1229
16	11 3/16	13 1/8	24	--	3	7200	1309
18	12 5/16	14 1/4	24	--	3	7200	1373
20	13 1/2	15 1/2	24	--	3	7200	1437



QWI 4.3.1 Issue Date Mar/12 Rev.6

*Note: when referencing a printed copy of this specification page please insure it is the latest version as found on our website at [www.taylorassociates.com](http://www.taylorassociates.com)*

### PIPE COVERING PROTECTION SADDLE #75 (4" Insulation)

- 4" through 20"
- Carbon Steel
- Bare Metal
- Complies with MSS SP-58 and MSS SP-69 (Type 39).
- Designed to protect pipe insulation from crushing, typically used on high temperature pipe lines.
- Specify pipe size, figure number, name and finish.
- Also available in Electro-Plated Zinc, Stainless Steel, and Hot Dipped Galvanized
  
- **All saddles 12" in length.**
- **Center rib starts at 12" IP**



IRON PIPE SIZE	SPECIFICATION DATA				ACTUAL THICKNESS OF COVERING	RECOM. MAX. LOAD (LBS.)	APP'X WT. PER 100 (LBS.)
	C	D	HANGER ROLLER SIZE				
			# 94/95	# 93			
4	6 9/16	7 11/16	12	14	4 1/16	1800	624
5	7 3/16	8 1/4	12	14	4 3/16	1800	624
6	7 5/8	9 1/8	14	16	4 1/8	1800	1001
8	8 11/16	10 1/8	16	18	4 1/8	1800	1001
10	9 11/16	11 5/16	18	20	4 1/16	1800	1097
12	10 13/16	12 3/8	20	--	4 1/8	5000	1485
14	11 7/16	13 1/8	20	--	4	5000	1485
16	12 5/16	14 3/16	24	--	4	7200	1564
18	13 1/2	15 7/16	24	--	4	7200	1628
20	14 3/16	16 5/8	30	--	4	7200	1692



QWI 4.3.1 Issue Date Mar/12 Rev.6

*Note: when referencing a printed copy of this specification page please insure it is the latest version as found on our website at [www.taylorassociates.com](http://www.taylorassociates.com)*



### PIPE COVERING PROTECTION SADDLE #76 (3 1/2" Insulation)

- 2" through 20"
- Carbon Steel
- Bare Metal
- Complies with MSS SP-58 and MSS SP-69 (Type 39).
- Designed to protect pipe insulation from crushing, typically used on high temperature pipe lines.
- Specify pipe size, figure number, name and finish.
- Also available in Electro-Plated Zinc, Stainless Steel, and Hot Dipped Galvanized
  
- All saddles 12" in length.**
- Center rib starts at 12" IP**



IRON PIPE SIZE	SPECIFICATION DATA				ACTUAL THICKNESS OF COVERING	RECOM. MAX. LOAD (LBS.)	APP'X WT. PER 100 (LBS.)
	C	D	HANGER ROLLER SIZE				
			# 94/95	# 93			
2	5 3/16	6	8	10	3 1/2	1800	432
2 1/2	4 7/16	6 1/4	8	10	3 1/2	1800	432
3	5 1/2	6 7/16	10	10	3 1/2	1800	475
3 1/2	6	6 13/16	10	12	3 1/2	1800	475
4	6 1/16	7	10	12	3 1/2	1800	475
5	6 5/8	7 9/16	12	12	3 1/2	1800	475
6	7 1/16	8 1/8	12	14	3 1/2	1800	873
8	8 1/8	9 5/8	14	16	3 1/2	1800	873
10	9 3/8	10 3/4	16	18	3 1/2	1800	937
12	10 3/16	11 13/16	18	20	3 1/2	5000	1325
14	10 3/4	12 3/8	20	24	3 1/2	5000	1325
16	11 11/16	13 5/8	24	--	3 1/2	7200	1405
18	12 13/16	14 3/4	24	--	3 1/2	7200	1469
20	14	16	30	--	3 1/2	7200	1533



QWI 4.3.1 Issue Date June/13 Rev.0

*Note: when referencing a printed copy of this specification page please insure it is the latest version as found on our website at [www.taylorassociates.com](http://www.taylorassociates.com)*

### PIPE COVERING PROTECTION SADDLE #77 (4 1/2" Insulation)

- 4" through 20"
- Carbon Steel
- Bare Metal
- Complies with MSS SP-58 and MSS SP-69 (Type 39).
- Designed to protect pipe insulation from crushing, typically used on high temperature pipe lines.
- Specify pipe size, figure number, name and finish.
- Also available in Electro-Plated Zinc, Stainless Steel, and Hot Dipped Galvanized
  
- **All saddles 12" in length.**
- **Center rib starts at 12" IP**

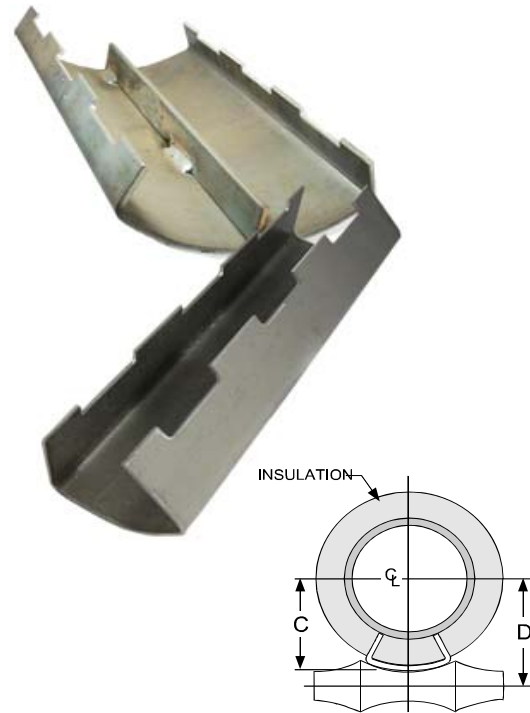

IRON PIPE SIZE	SPECIFICATION DATA				ACTUAL THICKNESS OF COVERING	RECOM. MAX. LOAD (LBS.)	APP'X WT. PER 100 (LBS.)
	C	D	HANGER ROLLER SIZE				
			# 94/95	# 93			
4	7 1/16	8 3/16	12	14	4 1/2	1800	667
5	7 11/16	8 3/4	14	16	4 1/2	1800	667
6	8 1/8	9 5/8	14	16	4 1/2	1800	1064
8	9 3/16	10 5/8	16	18	4 1/2	1800	1064
10	10 3/16	11 13/16	18	20	4 1/2	1800	1160
12	11 5/16	12 7/8	20	24	4 1/2	5000	1581
14	11 15/16	13 5/8	24	24	4 1/2	5000	1581
16	12 13/16	14 11/16	24	--	4 1/2	7200	1660
18	14	15 15/16	24	--	4 1/2	7200	1724
20	14 11/16	17 1/8	30	--	4 1/2	7200	1788



QWI 4.3.1 Issue Date May/13 Rev.0

*Note: when referencing a printed copy of this specification page please insure it is the latest version as found on our website at [www.taylorassociates.com](http://www.taylorassociates.com)*

**PIPE ALIGNMENT GUIDE #255**

- 1" through 16" pipe, 0 - 5" insulation.
- Carbon Steel
- Bare Metal
- Designed for use in directing thermal expansion of insulated or non-insulated pipe in the direction permitted by expansion joints or loops.
- Specify pipe size, guide size, insulation thickness, figure number, and name.
- Also available in Electro-Plated Zinc, Stainless Steel, and Hot Dipped Galvanized
  
- Maximum Temperature 650°

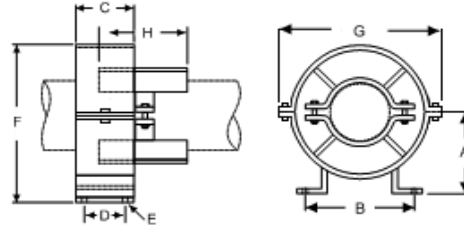

IRON PIPE SIZE	GUIDE SIZE SELECTION TABLE							
	INSULATION THICKNESS							
	0	1	1 1/2	2	2 1/2	3	4	5
1	2	2	2	3	4	4	5	6
1 1/4	2	2	3	4	4	5	5	6
1 1/2	2	2	3	4	4	5	6	7
2	2	2	3	4	4	5	6	7
2 1/2	3	3	4	4	5	5	6	7
3	3	3	4	4	5	5	6	8
3 1/2	4	4	4	5	5	6	7	8
4	4	4	4	5	5	6	7	8
5	5	5	5	5	6	6	8	9
6	5	5	5	6	6	7	8	9
8	7	7	7	7	8	8	9	10
10	9	9	9	9	9	9	10	11
12	10	10	10	10	10	10	11	11
14	11	11	11	11	11	11	11	-
16	11	11	11	11	11	11	-	-

GUIDE SIZE	SPECIFICATION DATA								APP'X WT. PER 100 (LBS.)
	A	B	C	D	E	F	G	H	
2	4	5 3/8	3	1 1/2	9/16	7 1/16	9 1/2	For 1" to 6" pipe H = 4"	1000
3	4 1/2	5 3/4	3	1 1/2	9/16	8 1/4	11 1/4		1100
4	6	7	3	1 1/2	9/16	10 3/4	12 3/4		1300
5	7 1/2	8 5/16	3	1 1/2	11/16	13 1/4	15 1/2		1700
6	8 1/2	8 3/4	4	2	11/16	15 1/2	17 1/2		2400
7	9 1/4	11 11/16	4	2	13/16	17	18 3/8		3100
8	10 1/8	12	4	2	13/16	18 3/8	20 1/2		3400
9	11	13 1/4	6	4	13/16	20 1/4	22 3/8	For 8" to 16" pipe H = 6"	5200
10	12	13 9/16	6	4	15/16	22 1/4	24		5900
11	13 3/4	15 1/4	6	4	15/16	26	28		7800



QWI 4.3.1 Issue Date Apr/16 Rev.7

*Note: when referencing a printed copy of this specification page please insure it is the latest version as found on our website at [www.taylorassociates.com](http://www.taylorassociates.com)*

### PIPE ALIGNMENT GUIDE #256

- 1" through 24" pipe, 0 - 5" insulation.
- Carbon Steel
- Bare Metal
- Designed for use in directing thermal expansion of insulated or non-insulated pipe in the direction permitted by expansion joints or loops.
- Specify pipe size, guide size, insulation thickness, figure number and name.
- Also available in Electro-Plated Zinc, Stainless Steel, and Hot Dipped Galvanized
- Maximum Temperature 750°

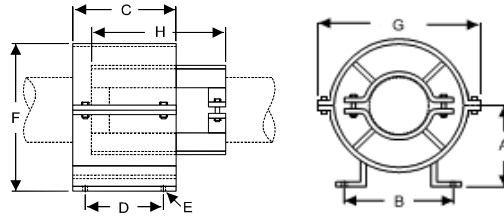

IRON PIPE SIZE	GUIDE SIZE SELECTION TABLE							
	INSULATION THICKNESS							
	0	1	1 1/2	2	2 1/2	3	4	5
1	2	2	2	3	4	4	5	6
1 1/4	2	2	3	4	4	5	5	6
1 1/2	2	2	3	4	4	5	6	7
2	2	2	3	4	4	5	6	7
2 1/2	3	3	4	4	5	5	6	7
3	3	3	4	4	5	5	6	8
3 1/2	4	4	4	5	5	6	7	8
4	4	4	4	5	5	6	7	8
5	5	5	5	5	6	6	8	9
6	5	5	5	6	6	7	8	9
8	7	7	7	7	8	8	9	10
10	9	9	9	9	9	9	10	11
12	10	10	10	10	10	10	11	11
14	11	11	11	11	11	11	11	12
16	11	11	11	11	11	11	12	13
18	12	12	12	12	12	12	13	13
20	13	13	13	13	13	13	13	14
24	14	14	14	14	14	14	14	--

GUIDE SIZE	SPECIFICATION DATA								APP'X WT. PER 100 (LBS.)
	A	B	C	D	E	F	G	H	
2	4	5 3/8	4	2 1/2	1/2	7 1/16	9 1/2	8	1300
3	4 1/2	5 3/4	4	2 1/2	1/2	8 1/4	11 1/4	9	1500
4	6	7	6	4	1/2	10 3/4	12 3/4	10	2600
5	7 1/2	8 5/16	6	4	5/8	13 1/4	15 1/2	10	3500
6	8 1/2	8 3/4	8	5	5/8	15 1/2	17 1/2	12	4800
7	9 1/4	11 11/16	8	5	3/4	17	18 3/8	12	5900
8	10 1/8	12	8	5	3/4	18 3/8	20 1/2	12	6600
9	11	13 1/4	8	5	3/4	20 1/4	22 3/8	12	6900
10	12	13 9/16	8	5	7/8	22 1/4	24	12	8800
11	13 3/4	15 1/4	8	5	7/8	26	28	12	13200
12	14 3/4	15 3/4	8	5	7/8	28	30	12	14400
13	16 1/4	18 3/4	8	5	1	31 1/2	34	12	15300
14	18 1/4	19 1/2	8	5	1	35 1/2	38	12	17200



QWI 4.3.1 Issue Date Apr/16 Rev.6

*Note: when referencing a printed copy of this specification page please insure it is the latest version as found on our website at [www.taylorassociates.com](http://www.taylorassociates.com)*

**PIPE SADDLE SUPPORT #520  
c/w SOLID STEM**

- 2" through 12"
- Carbon Steel
- Bare Metal
- Complies with Manufacturers' Standardization Society  
MSS SP-58 and SP-69 (Type 36)
- Designed for use on horizontal or gently sloping pipe  
lines running close to floor. Stem is solid rod  
designed to be inserted into vertical standing pipe.
- Specify pipe size, figure number, name and finish.
- Also available in Electro-Plated Zinc, Hot Dipped Galvanized



IRON PIPE SIZE	SPECIFICATION DATA		DIAMETER AND LENGTH OF STEM	APP'X WT. PER 100 (LBS.)
	MATERIAL			
2	3/8 x 1 1/2		7/8 x 6	157
3	3/8 x 1 1/2		7/8 x 6	185
4	3/8 x 2		1 x 6	270
5	3/8 x 2		1 x 6	314
6	1/2 x 2		1 1/4 x 6	490
8	1/2 x 2		1 1/4 x 6	575
10	1/2 x 3		1 1/2 x 6	988
12	1/2 x 3		1 1/2 x 6	1140



QWI 4.3.1 Issue Date Mar/12 Rev.3

*Note: when referencing a printed copy of this specification page please insure it is the latest version as found on our website at [www.taylorassociates.com](http://www.taylorassociates.com)*

### ADJUSTABLE PIPE SADDLE SUPPORT WITH THREADED COUPLING #521

- 2" through 12"
- Carbon Steel
- Bare Metal
- Designed for use on horizontal or gently sloping pipe lines.
- Specify pipe size, figure number, name and finish.
- Also available in Electro-Plated Zinc



IRON PIPE SIZE	SPECIFICATION DATA		PIPE SIZE, COUPLING	APP'X WT. PER 100 (LBS.)
	MATERIAL			
2	3/8 x 2		1 1/4	192
3	3/8 x 2 1/2		1 1/2	220
4	3/8 x 3		2	323
5	3/8 x 3		2	367
6	1/2 x 3 1/2		2 1/2	592
8	1/2 x 3 1/2		2 1/2	677
10	1/2 x 4		3	1156
12	1/2 x 4		3	1308



QWI 4.3.1 Issue Date Mar/12 Rev.3

*Note: when referencing a printed copy of this specification page please insure it is the latest version as found on our website at [www.taylorassociates.com](http://www.taylorassociates.com)*

# #192 Adjustable Pipe Saddle

**Finish:** Bare Metal, Zinc Plated, Hot Dipped Galvanized

**Material:** Carbon Steel, Stainless Steel 304SS & 316SS

**Approvals:** Complies with MSS-SP-69 (Type 38)

**Recommended:** Pipe stanchion support for stationary pipe where vertical adjustment is required.



IRON PIPE SIZE	SPECIFICATION DATA		APPROX. WT. PER 100 (Lbs)
	SADDLE MATERIAL	DIAMETER & LENGTH OF STEM	
2	1/4 x 1	5/8 x 8	100
2 1/2	1/4 x 1	5/8 x 8	140
3	1/4 x 1	5/8 x 8	160
3 1/2	1/4 x 1	5/8 x 8	260
4	1/4 x 1 1/4	7/8 x 8	300
5	1/4 x 1 1/4	7/8 x 8	320
6	3/8 x 1 1/2	1 x 8	490
8	3/8 x 1 1/2	1 x 8	620
10	1/2 x 2	1 1/4 x 8	1050
12	1/2 x 2	1 1/4 x 8	1180



QWI 4.3.1 Issue Date Feb/17 Rev.0

Note: when referencing a printed copy of this specification page, please insure it is the latest version as found on our website at [www.taylorassociates.com](http://www.taylorassociates.com)

For more information, please contact Customer Service at 1-800-263-8652

### ADJUSTABLE PIPE SUPPORT #525 c/w U-BOLT

- 4" through 36"
- Carbon steel, saddle, support and U-Bolt.
- Bare Metal
- Complies with Manufacturers' Standardization Society  
MSS SP-58 and SP-69 (Type 36, 37)
- Designed to be used in conjunction with a base stand  
to support pipe running close to the floor.  
U-Bolt secures pipe to saddle.
- Specify pipe size, figure number, name and finish.  
Base stand ordered separately. Requires accurate center line  
of pipe to floor dimension "L".
- Also available in Electro-Plated Zinc, Stainless Steel

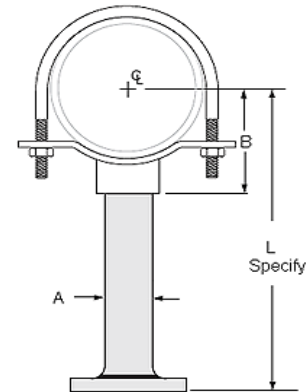

PIPE SIZE	SPECIFICATION DATA		WGT. EACH (LBS.)
	PIPE SIZE A	B	
4	3	4 3/16	11
5	3	4 13/16	12
6	3	5 7/16	13
8	3	6 15/16	14
10	3	8 7/16	16
12	3	9 15/16	22
14	4	10 15/16	28
16	4	12 3/8	31
18	4	13 7/8	40
20	6	15 3/8	57
24	6	17 15/16	79
30	8	21 5/16	95
36	8	24 1/2	109



QWI 4.3.1 Issue Date Feb/13 Rev.3

*Note: when referencing a printed copy of this specification page please insure it is the latest version as found on our website at [www.taylorassociates.com](http://www.taylorassociates.com)*



**ADJUSTABLE PIPE SADDLE SUPPORT #526**

2 1/2" through 36"

Carbon Steel Saddle and Nipple with  
Cast Iron Reducing Coupling

Bare Metal

Complies with MSS SP-58 and SP-69 (Type 38).

Pipe support for horizontal pipe lines where  
vertical adjustment is required.

Specify pipe size, figure number, name,  
finish.

Base stand ordered separately. Requires accurate  
center line of pipe to floor dimension "L".

Also available in Electro-Plated Zinc & 304/316SS

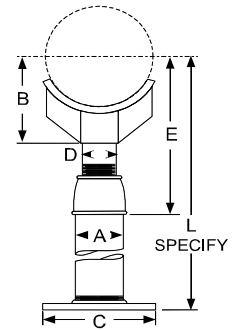

IRON PIPE SIZE	SPECIFICATION DATA				Dimension E		APP'X LBS PER 100	
	A	B	C	D	MIN.	MAX.	COMPLETE	SADDLE ONLY
<b>2 1/2</b>	2 1/2	3 7/16	8	1 1/2	8	13	900	480
<b>3</b>	2 1/2	3 11/16	8	1 1/2	8 1/4	13 1/4	920	500
<b>3 1/2</b>	2 1/2	3 15/16	8	1 1/2	8 1/2	13 1/2	940	520
<b>4</b>	3	4 3/16	10	2 1/2	9 1/4	14	1500	760
<b>5</b>	3	4 13/16	10	2 1/2	10	14 3/4	1665	925
<b>6</b>	3	5 7/16	10	2 1/2	10 1/2	15 1/4	1765	1025
<b>8</b>	3	6 15/16	10	2 1/2	11 3/4	16 1/2	2020	1280
<b>10</b>	3	8 7/16	10	2 1/2	13 1/2	18 1/4	2515	1775
<b>12</b>	3	9 15/16	10	2 1/2	15	19 3/4	2900	2160
<b>14</b>	4	10 15/16	10	3	16 1/4	20 3/4	4920	3800
<b>16</b>	4	12 3/8	10	3	17 3/4	22 1/4	5320	4200
<b>18</b>	6	13 7/8	12	4	19 1/2	24	7080	5100
<b>20</b>	6	15 3/8	12	4	21	25 1/2	10480	8500
<b>24</b>	6	17 15/16	12	4	23 3/4	28 1/4	13000	11000
<b>30</b>	6	21 5/16	12	4	27	31 1/2	17000	15000
<b>32</b>	6	22 1/2	12	4	28 1/4	32 3/4	18100	16100
<b>36</b>	6	24 1/2	12	4	30 1/4	34 3/4	24900	22900

**Note:** 8" and larger supplied with gussets at pipe support



QWI 4.3.1 Issue Date Aug/14 Rev.5

*Note: when referencing a printed copy of this specification page please insure it is the latest version as found on our website at [www.taylorassociates.com](http://www.taylorassociates.com)*

## ADJUSTABLE PIPE SADDLE SUPPORT #527 c/w U-BOLT

2 1/2" through 36"

Carbon Steel Saddle, nipple and U-Bolt  
with cast iron reducing coupling.

Bare Metal

Complies with MSS SP-58 and SP-69 (Type 37, 38).

Designed to be used in conjunction with a base stand  
to support horizontal pipe. Straight cut pipe thread on  
nipple provides adjustability, U-Bolt secures pipe to  
saddle.

Specify pipe size, figure number, name and finish.

Base stand ordered separately. Requires accurate  
center line of pipe to floor dimension "L".

Also available in Electro-Plated Zinc & 304/316SS

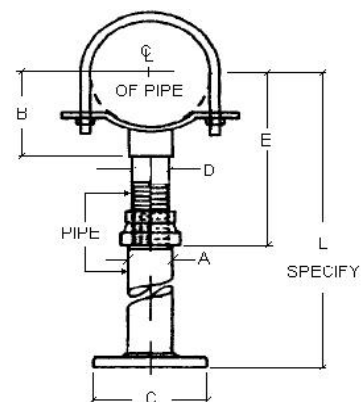

IRON PIPE SIZE	SPECIFICATION DATA				Dimension E		APP'X LBS PER 100	
	A	B	C	D	MIN.	MAX.	COMPLETE	SADDLE ONLY
2 1/2	2 1/2	3 7/16	8	1 1/2	8	13	900	480
3	2 1/2	3 11/16	8	1 1/2	8 1/4	13 1/4	920	500
3 1/2	2 1/2	3 15/16	8	1 1/2	8 1/2	13 1/2	940	520
4	3	4 3/16	10	2 1/2	9 1/4	14	1500	760
5	3	4 13/16	10	2 1/2	10	14 3/4	1665	925
6	3	5 7/16	10	2 1/2	10 1/2	15 1/4	1765	1025
8	3	6 15/16	10	2 1/2	11 3/4	16 1/2	2020	1280
10	3	8 7/16	10	2 1/2	13 1/2	18 1/4	2515	1775
12	3	9 15/16	10	2 1/2	15	19 3/4	2900	2160
14	4	10 15/16	10	3	16 1/4	20 3/4	4920	3800
16	4	12 3/8	10	3	17 3/4	22 1/4	5320	4200
18	6	13 7/8	12	4	19 1/2	24	7080	5100
20	6	15 3/8	12	4	21	25 1/2	10480	8500
24	6	17 15/16	12	4	23 3/4	28 1/4	13000	11000
30	6	21 5/16	12	4	27	31 1/2	17000	15000
32	6	22 1/2	12	4	28 1/4	32 3/4	18100	16100
36	6	24 1/2	12	4	30 1/4	34 3/4	24900	22900



QWI 4.3.1 Issue Date Mar/12 Rev.2

*Note: when referencing a printed copy of this specification page please insure it is the latest version as found on our website at [www.taylorassociates.com](http://www.taylorassociates.com)*

## #528KT ADJUSTABLE PIPE SADDLE SUPPORT KIT

Ductile iron saddle with carbon steel coupling, carbon steel nipple and base plate, cast steel reducing coupling, stainless steel set screws.

All items listed above are hot-dip galvanized except for stainless steel set screws.

Designed to support pipe horizontally. Straight cut pipe thread on nipple provides up to 4 1/2" of vertical adjustability.

Specify pipe size and figure number.

Saddles accommodate ductile iron pipe and IPS. Support requires 2" Schedule 40 (for 2" - 12") or 3" Schedule 40 (for 14" - 16") extension pipe to be cut in the field.

Also available in 316 stainless steel up to 12"

Complies with MSS SP-58 and SP-69 (Type 36, 38).

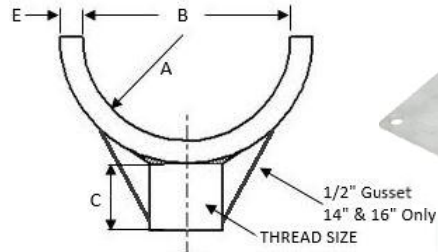

IPS or Ductile Iron Pipe Size	SPECIFICATION DATA				
	A	B	C	E	THREAD SIZE
2	1.750"	3.500"	1 1/2	3/8 x 2	1 1/4 - 7
3	2.030"	4.060"	1 1/2	3/8 x 2	1 1/4 - 7
4	2.450"	4.900"	1 1/2	3/8 x 2	1 1/4 - 7
6	3.500"	7.000"	1 1/2	1/2 x 2	1 1/4 - 7
8	4.580"	9.160"	1 1/2	1/2 x 2	1 1/4 - 7
10	5.600"	11.200"	1 1/2	1/2 x 2	1 1/4 - 7
12	6.650"	13.300"	1 1/2	1/2 x 2	1 1/4 - 7
14	7.750"	15.500"	3	1/2 x 3	1 1/2 - 4
16	8.800"	17.600"	3	1/2 x 3	1 1/2 - 4

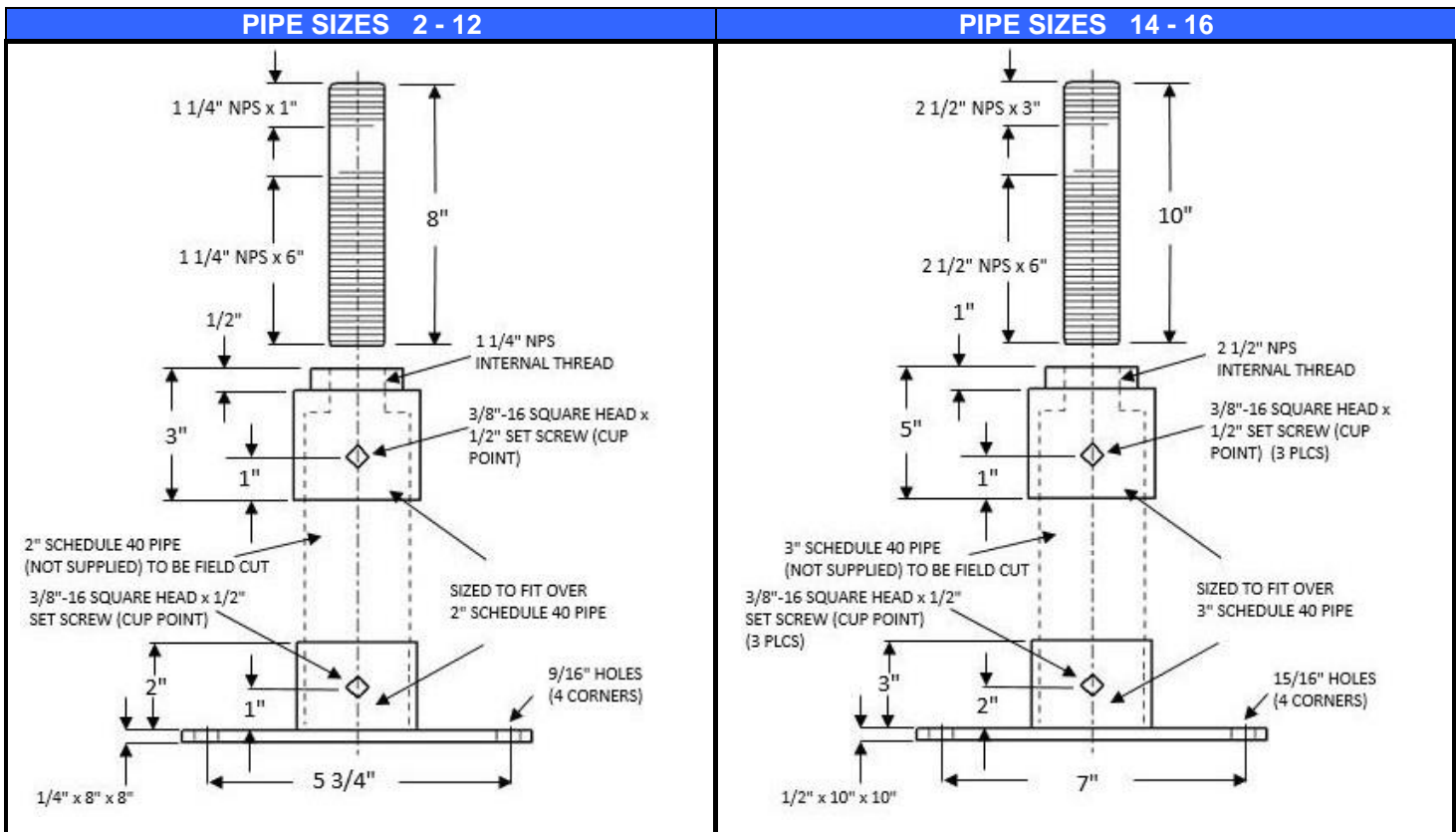

QWI 4.3.1 Issue Date Apr/18 Rev.4

Note: when referencing a printed copy of this specification page please insure it is the latest version as found on our website at [www.taylorassociates.com](http://www.taylorassociates.com)



## #529KT ADJUSTABLE PIPE SADDLE SUPPORT c/w U-BOLT KIT

Ductile iron saddle with carbon steel coupling, carbon steel nipple and base plate, cast steel reducing coupling, stainless steel set screws.

All items listed above are hot-dip galvanized except for stainless steel set screws.

Designed to support pipe horizontally. Straight cut pipe thread on nipple provides up to 4 1/2" of vertical adjustability.

Specify pipe size and figure number.

Saddles accommodate ductile iron pipe and IPS. Support requires 2" Schedule 40 (for 3" - 12") or 3" Schedule 40 (for 14" - 16") extension pipe to be cut in the field.

Also available in 316 stainless steel up to 12"

Complies with MSS SP-58 and SP-69 (Type 37, 38).

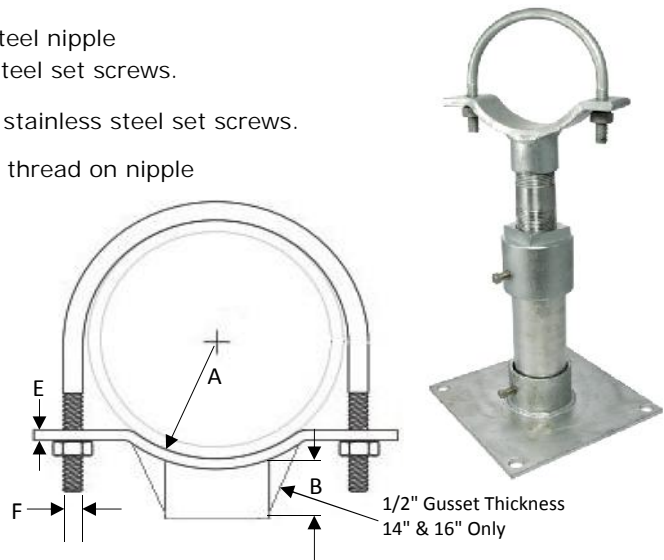

IPS or Ductile Iron Pipe Size	SPECIFICATION DATA				
	A	B	E	F	THREAD SIZE
3	2.030"	1 1/2	3/8 x 2	1/2-13	1 1/4 - 7
4	2.450"	1 1/2	3/8 x 2	1/2-13	1 1/4 - 7
6	3.500"	1 1/2	1/2 x 2	5/8-11	1 1/4 - 7
8	4.580"	1 1/2	1/2 x 2	5/8-11	1 1/4 - 7
10	5.600"	1 1/2	1/2 x 2	5/8-11	1 1/4 - 7
12	6.650"	1 1/2	1/2 x 2	5/8-11	1 1/4 - 7
14	7.750"	3	1/2 x 3	7/8-9	1 1/2 - 4
16	8.800"	3	1/2 x 4	7/8-9	1 1/2 - 4

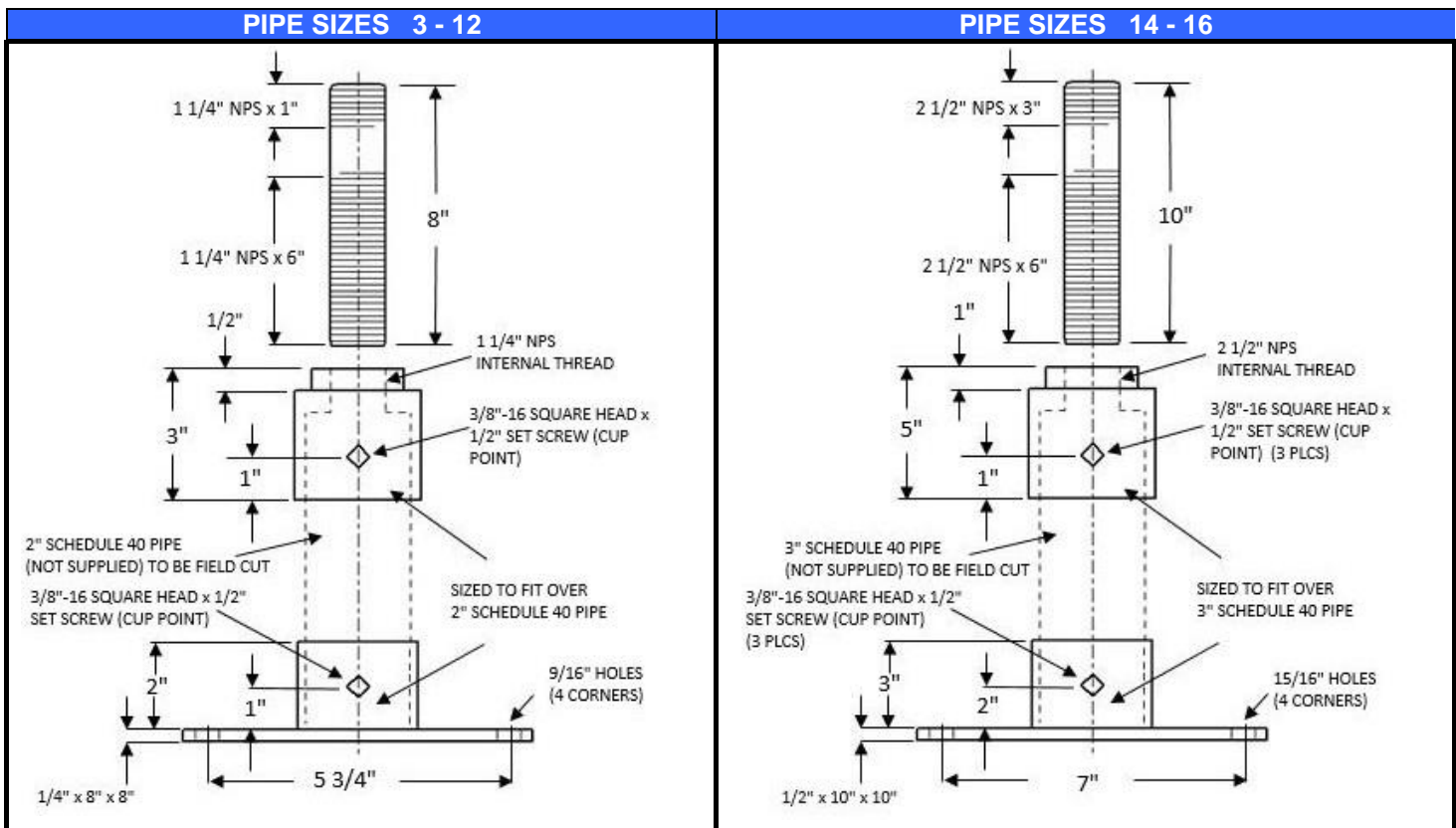

QWI 4.3.1 Issue Date Apr/18 Rev.4

Note: when referencing a printed copy of this specification page please insure it is the latest version as found on our website at [www.taylorassociates.com](http://www.taylorassociates.com)

**TAYLOR**  
PIPE SUPPORTS

**STUD PLATE #501**

- 3", 4", 6" and 8" lengths
- Carbon Steel
- Bare Metal
- Designed to apply to wooden stud to protect plumbing and electrical lines from drywall screws and other fasteners.
- Specify length, figure number and name.

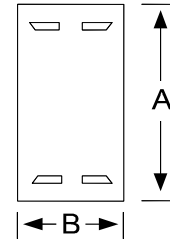

LENGTH A	SPECIFICATION DATA		APPROX. WT. PER 100 (LBS)	PC'S. PER PKG.
	B	MATERIAL		
3"	1 1/2	18 gauge	6	100
4"	1 1/2	18 gauge	8	100
6"	1 1/2	18 gauge	11	100
8"	1 1/2	18 gauge	15	50



QWI 4.3.1 Issue Date Dec/06 Rev.2

*Note: when referencing a printed copy of this specification page please insure it is the latest version as found on our website at [www.taylorassociates.com](http://www.taylorassociates.com)*

**PIPE ROLL #92**

- 2" through 30"
- Gray Iron ASTM A-48 Class 25A
- Bare Metal
- Pipe support designed for pipe lines where horizontal movement may take place due to expansion and contraction.
- Specify pipe size, figure number, name and finish.
- Also available in Electro-Plated Zinc, and Hot Dipped Galvanized

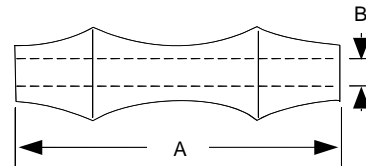

IRON PIPE SIZE	SPECIFICATION DATA		APPR'X WT. PER 100 (LBS)
	A	B (Rod Size)	
2	2 7/8	3/8	31
2 1/2	3 1/8	1/2	31
3	3 3/4	1/2	39
3 1/2	3 7/8	1/2	47
4	4 3/4	1/2	67
5	5 3/4	5/8	93
6	6 7/8	3/4	160
8	8 7/8	7/8	270
10	11	7/8	360
12	13	7/8	620
14	14 1/4	1 1/8	954
16	16 3/4	1 1/4	1260
18	18 5/16	1 1/4	1430
20	20 1/4	1 1/4	1670
24	24 1/4	1 1/2	2900
30	30 1/4	1 3/4	5100



QWI 4.3.1 Issue Date Feb/14 Rev.6

*Note: when referencing a printed copy of this specification page please insure it is the latest version as found on our website at [www.taylorassociates.com](http://www.taylorassociates.com)*

**SHORT PIPE ROLL - #92S**

- 2" through 42"
- Cast Iron
- Bare Metal
- Pipe support designed for pipe lines where horizontal movement may take place due to expansion and contraction.
- Specify pipe size, figure number, name and finish.
- Also available in Electro-Plated Zinc, Hot Dipped Galvanized, and Stainless Steel

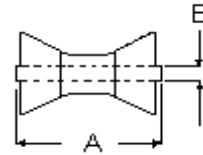

IRON PIPE SIZE	SPECIFICATION DATA		APPR'X WT. PER 100 (LBS)
	A	B (Rod Size)	
2" - 3 1/2"	2 3/4	1/2	66
4" - 6"	3 3/4	1/2	110
8" - 10"	6	3/4	330
12" - 14"	8	7/8	550
16" - 20"	9	1 1/8	880
24"	10	1 1/4	1100
26" - 30"	12 3/8	1 3/4	2100
36" - 42"	15	2	3000



QWI 4.3.1 Issue Date Feb/14 Rev.5

*Note: when referencing a printed copy of this specification page please insure it is the latest version as found on our website at [www.taylorassociates.com](http://www.taylorassociates.com)*

## ADJUSTABLE ROLLER HANGER #93

2" through 24"

Cast Iron Roller, Carbon Steel yoke and hardware.

Bare Metal

Complies with MSS SP-58 and SP-69 (Type 43).

Pipe support designed for pipe lines where horizontal movement may take place due to expansion and contraction.

Specify pipe size, figure number, name and finish.

Also available in Electro-Plated Zinc, Stainless Steel, and Hot Dipped Galvanized

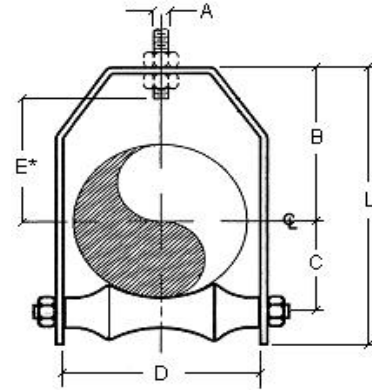

IRON PIPE SIZE	SPECIFICATION DATA							RECOM. MAX. LOAD (LBS)	APP'X WT. PER 100 (LBS)
	A	B	C	D	E*	L	MATERIAL		
2	1/2	4	1 5/8	3 1/8	2 1/4	6 1/2	1/4 x 1 1/4	280	168
2 1/2	1/2	3 7/8	2	3 3/8	2 3/4	6 5/8	1/4 x 1 1/4	280	195
3	1/2	4 3/8	2 1/4	4	3 3/8	7 1/4	1/4 x 1 1/4	310	200
3 1/2	1/2	4 5/8	2 1/2	4 1/2	3 5/8	8	1/4 x 1 1/4	390	260
4	5/8	4 3/4	2 3/4	5	3 3/4	8 1/2	1/4 x 1 1/2	475	300
5	5/8	5 7/8	3 3/8	6	4 1/4	10 1/4	5/16 x 1 1/2	600	512
6	3/4	5 7/8	4	7	4 1/4	11 3/8	3/8 x 2	780	650
8	7/8	7 1/4	5 1/8	9 1/4	5 1/2	13 3/4	3/8 x 2	780	1200
10	7/8	9	6 3/8	11 1/4	6 7/8	16 7/8	1/2 x 2	965	1715
12	7/8	9 5/8	7 3/8	13 1/4	7 7/8	18 7/8	1/2 x 2 1/2	1200	2750
14	1	11 1/4	8 3/8	14 3/4	9 1/4	21 7/8	1/2 x 2 1/2	1200	3600
16	1	12 1/4	9 3/8	17	10 1/4	24 1/8	1/2 x 2 1/2	1200	4945
18	1	13 1/4	10 1/2	18 3/4	11 1/4	26 3/8	1/2 x 3	1400	5535
20	1 1/4	14 1/4	11 5/8	20 1/4	12 1/4	28 1/8	5/8 x 3	1600	6335
24	1 1/2	15 7/8	14	24 3/4	15 3/4	31 7/8	5/8 x 4	1800	11930

\* Rod Take-Out



QWI 4.3.1 Issue Date Jun/17 Rev.9

*Note: when referencing a printed copy of this specification page please insure it is the latest version as found on our website at [www.taylorassociates.com](http://www.taylorassociates.com)*



## ROLLER CHAIR #94

2" through 24"

Cast Iron Roller, Carbon Steel Chair and Hardware

Bare Metal

Complies with MSS SP-58 and SP-69 (Type 44).

Pipe support designed for pipe lines where horizontal movement may take place due to expansion and contraction.

Specify pipe size, figure number, name and finish.

Also available in Electro-Plated Zinc, and Hot Dipped Galvanized and Stainless Steel

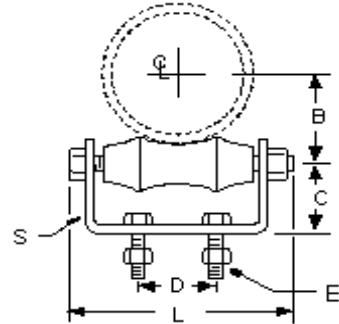

IRON PIPE SIZE	SPECIFICATION DATA						RECOM. MAX. LOAD (LBS)	APP'X WT. PER 100 (LBS)
	B	C	D	E	L	S		
2	1 1/2	1 1/2	1 1/4	3/8	3 7/8	1/4 x 1 1/4	390	106
2 1/2	2	1 5/8	1 1/4	3/8	5	1/4 x 1 1/4	390	144
3	2 1/4	1 3/4	2	3/8	5 3/8	1/4 x 1 1/4	390	163
3 1/2	2 1/2	2	2	3/8	6 1/4	3/8 x 1 1/2	390	252
4	2 7/8	2 1/4	2	1/2	6 3/4	3/8 x 1 1/2	950	288
5	3 3/8	2 1/2	3	1/2	8	3/8 x 1 1/2	950	400
6	3 7/8	2 3/4	3 1/8	1/2	9 1/8	3/8 x 2	950	625
8	5 1/8	3	3 3/8	5/8	11 1/2	3/8 x 2	1350	731
10	6 3/8	3 5/8	5 1/2	5/8	14 1/4	1/2 x 2	1750	1158
12	7 1/2	4 1/8	5 1/2	5/8	16 1/4	1/2 x 2	2400	1525
14	8 3/8	4 11/16	6 1/2	3/4	18	1/2 x 2 1/2	3130	2807
16	9 3/8	5 3/8	8 1/4	3/4	20	1/2 x 3	3970	3493
18	10 7/16	6	9 1/4	3/4	23	1/2 x 3	4200	4435
20	11 5/8	6 1/2	10 1/4	3/4	26	1/2 x 3	4550	5634
24	14	7 7/8	12 1/4	7/8	30	5/8 x 4	6160	8752



QWI 4.3.1 Issue Date Mar/12 Rev. 7

*Note: when referencing a printed copy of this specification page please insure it is the latest version as found on our website at [www.taylorassociates.com](http://www.taylorassociates.com)*

### SHORT ROLLER CHAIR #94S

- 2" through 14"
- Cast Iron Roller, Carbon Steel Chair and Hardware
- Bare Metal
- Complies with MSS SP-58 and SP-69 (Type 44).
- Compact pipe support designed for pipe lines where horizontal movement may take place due to expansion and contraction.
- Specify pipe size, figure number, name and finish.
- Also available in Electro-Plated Zinc, Stainless Steel and Hot Dipped Galvanized

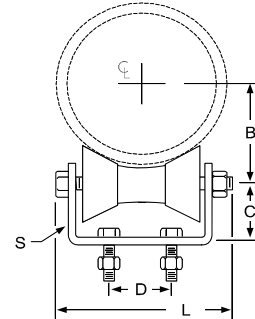

IRON PIPE SIZE	SPECIFICATION DATA									RECOM. MAX. LOAD (LBS)	APP'X WT. PER 100 (LBS)
	B					C	D	L	S		
2 - 3 1/2	For Size	2"	2 1/2"	3"	3 1/2"	1 3/4	1 3/8	4 1/2	1/4 x 2	390	215
	B =	1 3/4	2 1/8	2 3/8	2 5/8						
4 - 6	For Size	4"		5"	6"	2 1/16	2	6 1/8	3/8 x 2 1/2	950	410
	B =	2 3/4	3 3/8	4							
8 - 10	For Size	8"		10"	3 7/16	4	8 3/4	3/8 x 3	2100	1060	
	B =	5 1/4	6 3/8								
12 - 14	For Size	12"		14"	3 7/8	5 3/4	11 1/4	1/2 x 4	3075	2130	
	B =	7 1/2	8 1/8								



QWI 4.3.1 Issue Date Jan/14 Rev.6

*Note: when referencing a printed copy of this specification page please insure it is the latest version as found on our website at [www.taylorassociates.com](http://www.taylorassociates.com)*

## ADJUSTABLE 2-ROD ROLLER HANGER #95

2" through 30"

Cast Iron Roller and Socket Ends, Carbon Steel Axle Rod  
Bare Metal

Complies with MSS SP-58 and SP-69 (Type 41).

Pipe support designed for pipe lines where  
horizontal movement may take place due to  
expansion and contraction.

Specify pipe size, figure number, name and finish.

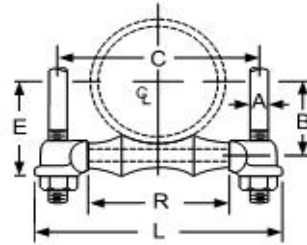
Also available in Electro-Plated Zinc, Stainless Steel  
and Hot Dipped Galvanized

IRON PIPE SIZE	SPECIFICATION DATA						RECOM. MAX. LOAD (LBS)	APP'X WT. PER 100 (LBS)
	A	B	C	E	L	R		
2	3/8	1 9/16	4 3/8	2 3/16	5 5/8	2 7/8	600	57
2 1/2	1/2	1 7/8	5 1/8	2 5/8	6 1/2	3 1/8	660	100
3	1/2	2 1/8	5 5/8	2 7/8	7	3 3/4	700	110
3 1/2	5/8	2 1/2	5 7/8	3 1/4	7 1/4	3 7/8	750	135
4	5/8	2 13/16	7	3 13/16	8 9/16	4 3/4	750	165
5	5/8	3 3/8	8 1/8	4 3/8	9 3/4	5 3/4	750	257
6	3/4	3 15/16	9 3/4	4 15/16	11 5/8	6 7/8	1070	445
8	7/8	5 1/8	12 1/8	6 3/8	14 1/4	8 7/8	1350	715
10	7/8	6 1/4	14	7 1/2	16 1/4	11	1730	950
12	7/8	7 5/16	15 3/4	8 9/16	18	13	2400	1590
14	1	8 3/8	17 3/4	9 13/16	20 1/2	14 1/4	3130	2425
16	1	9 1/2	20 9/16	10 15/16	23 3/8	16 7/8	3970	3185
18	1	10 7/16	22	11 7/8	24 7/8	18 5/16	4200	3550
20	1 1/4	11 1/2	24	13 3/8	27	20 1/4	4550	4700
24	1 1/2	13 13/16	28 3/4	16 1/8	32	24 1/4	6160	7630
30	1 1/2	17 1/4	35 5/8	19 5/8	39 3/4	30 1/4	7290	12990



QW1 4.3.1 Issue Date Jun/17 Rev.9

*Note: when referencing a printed copy of this specification page please insure it is the latest version as found on our website at [www.taylorassociates.com](http://www.taylorassociates.com)*

## ADJUSTABLE 2-ROD ROLLER SUPPORT #95S

- 2" through 30"
- Cast Iron Roller and Socket Ends, Carbon Steel Axle Rod and 2 Drop Rods c/w 8 Hex. Nuts
- Bare Metal
- Complies with MSS SP-58 and SP-69 (Type 41).
- Designed for the support of pipe where longitudinal movement may occur due to expansion and contraction, and vertical adjustment of up to 6 inches may be necessary.
- Specify roller size, figure number, name and finish.
- Also available in Electro-Plated Zinc
  
- *Please remember to consider insulation thickness when sizing rollers.*

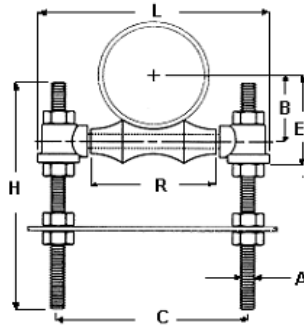

PIPE ROLLER SIZE	SPECIFICATION DATA									REC. MAX LOAD (lbs)	APP'X WT. PER 100 PCS
	PIPE OD	AXLE SIZE	A	B	C	E	H	L	R		
2	2.375	3/8	3/8	1 9/16	4 3/8	2 3/16	12	5 5/8	2 7/8	600	145
2 1/2	2.875	1/2	1/2	1 7/8	5 1/8	2 5/8	12	6 1/2	3 1/8	600	254
3	3.500	1/2	1/2	2 1/8	5 5/8	2 7/8	12	7	3 3/4	700	274
3 1/2	4.000	1/2	5/8	2 1/2	5 7/8	3 1/4	12	7 1/4	3 7/8	750	285
4	4.500	1/2	5/8	2 13/16	7	3 13/16	12	8 9/16	4 3/4	750	432
5	5.563	5/8	5/8	3 3/8	8 1/8	4 3/8	12	9 3/4	5 3/4	750	478
6	6.625	3/4	3/4	3 15/16	9 3/4	4 15/16	12	11 5/8	6 7/8	1070	771
8	8.625	7/8	7/8	5 1/8	12 1/8	6 3/8	12	14 1/4	8 7/8	1350	1221
10	10.750	7/8	7/8	6 1/4	14	7 1/2	12	16 1/4	11	1730	1395
12	12.750	7/8	7/8	7 5/16	15 3/4	8 9/16	12	18	13	2400	1793
14	14.000	1 1/8	1	8 3/8	17 3/4	9 13/16	18	20 1/2	14 1/4	3130	2755
16	16.000	1 1/4	1	9 1/2	20 9/16	10 15/16	18	23 3/8	16 7/8	3970	3334
18	18.000	1 1/4	1	10 7/16	22	11 7/8	18	24 7/8	18 5/16	4200	3600
20	20.000	1 1/4	1 1/4	11 1/2	24	13 3/8	18	27	20 1/4	4550	4660
24	24.000	1 1/2	1 1/2	13 13/16	28 3/4	16 1/8	20	32	24 1/4	6160	8122
30	30.000	1 3/4	1 1/2	17 1/4	35 5/8	19 5/8	24	39 3/4	30 1/4	7290	10922



QWI 4.3.1 Issue Date Mar/12 Rev.6

*Note: when referencing a printed copy of this specification page please insure it is the latest version as found on our website at [www.taylorassociates.com](http://www.taylorassociates.com)*

**PIPE ROLL STAND #279S**

- 2" through 42"
- Cast Iron Roller, Carbon Steel Chair and Axle
- Bare Metal
- Complies with MSS SP-58 and SP-69 (Type 44).
- For support of pipe where longitudinal movement may occur due to expansion and contraction and where vertical adjustment is not necessary.
- Specify rod size, figure number, name and finish.
- Also available in Electro-Plated Zinc, and Hot Dipped Galvanized

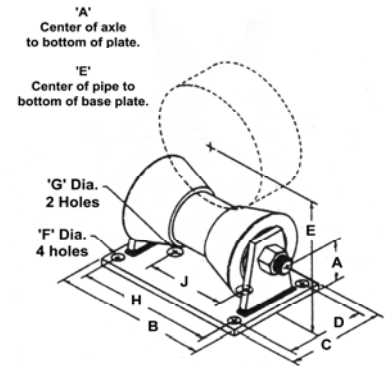

PIPE SIZE	SPECIFICATION DATA									WEIGHT PER 100 (LBS)	MAX. REC. LOAD
	A	B	C	D	E	F	G	H	J		
2	1 3/4	8 3/8	6	4	3 11/16	9/16	1	6 3/8	3 3/8	508	390
2 1/2	1 3/4	8 3/8	6	4	3 15/16	9/16	1	6 3/8	3 3/8	508	390
3	1 3/4	8 3/8	6	4	4 1/4	9/16	1	6 3/8	3 3/8	508	390
3 1/2	1 3/4	8 3/8	6	4	4 1/2	9/16	1	6 3/8	3 3/8	508	390
4	2	9 7/8	6	4 1/4	5	9/16	1	7 7/8	4 3/4	631	950
5	2	9 7/8	6	4 1/4	5 9/16	9/16	1	7 7/8	4 3/4	631	950
6	2	9 7/8	6	4 1/4	6 1/16	9/16	1	7 7/8	4 3/4	631	950
8	3 3/8	8 5/8	8	5	8 13/16	11/16	1	7	4	1365	2100
10	3 3/8	8 5/8	8	5	9 7/8	11/16	1	7	4	1365	2100
12	3 7/8	11	8	6	11 7/16	13/16	1	9	5 3/4	2100	3075
14	3 7/8	11	8	6	12 1/6	13/16	1	9	5 3/4	2100	3075
16	4 1/4	12 3/8	10	6 1/2	13 5/8	13/16	1	10 3/8	6 3/4	3423	4980
18	4 1/4	12 3/8	10	6 1/2	14 11/16	13/16	1	10 3/8	6 3/4	3423	4980
20	4 1/4	12 3/8	10	6 1/2	15 11/16	13/16	1	10 3/8	6 3/4	3423	4980
24	4 3/8	13 1/2	10	6 1/2	17 11/16	13/16	1	11 1/2	7 1/2	4000	6100
30	5 1/8	17	10	7 3/4	21 3/4	1 1/16	1	14 1/4	10	7132	7500
36	5 3/4	20	12	9	25 3/4	1 3/8	1	17	12	14700	12000
42	5 3/4	20	12	9	28 7/8	1 3/8	1	17	12	14700	12000



QWI 4.3.1 Issue Date Oct/13 Rev.2

*Note: when referencing a printed copy of this specification page please insure it is the latest version as found on our website at [www.taylorassociates.com](http://www.taylorassociates.com)*

**CHANNEL ASSEMBLY #170**

- Carbon Steel
- Bare Metal or Galvanized
- Specify Fig. #170 channel assembly, channel size, rod size, name, finish and C to C.  
Note: that  $L = (C \text{ to } C) + 2M + W$
- Can also be used with a U-Bolt Fig. #14 & Fig. #80 washer plates to secure pipe to the center of channel assembly.

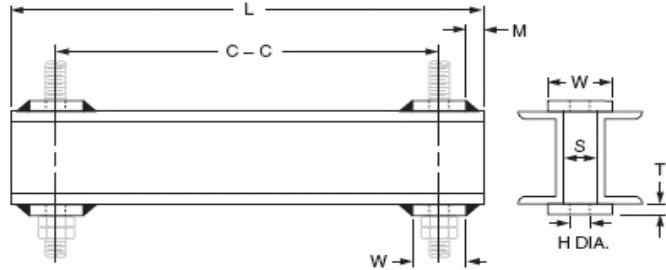

**Figure #170: DIMENSIONS (Inches)**

ROD DIA.	3/8	1/2	5/8	3/4	7/8	1	1 1/4	1 1/2	1 3/4	2	2 1/4	2 1/2	2 3/4	3	3 1/4	3 1/2
<b>H Hole</b>	1/2	5/8	3/4	7/8	1	1 1/4	1 1/2	1 3/4	2	2 1/4	2 1/2	2 3/4	3	3 1/4	3 1/2	3 3/4
<b>S</b>	9/16	11/16	13/16	15/16	1 1/16	1 3/8	1 5/8	1 7/8	2 1/4	2 1/2	2 3/4	3	3 1/4	3 1/2	3 3/4	4
<b>W</b>	3	3	3	4	4	4	5	5	5	5	6	6	6	6	6	7
<b>T</b>	1/4	1/4	3/8	3/8	1/2	1/2	1/2	3/4	3/4	3/4	3/4	3/4	3/4	3/4	3/4	3/4
<b>M</b>	3/8	3/8			3/8	3/8	3/8	3/8	3/8	3/8	3/8	3/8	3/8	3/8	3/8	1/2

**Figure #170: WEIGHTS (Lbs.) • LOADS (Lbs.) • C To C = SPAN (Inches)**

Size	Wt./Ft. 2C's	Maximum Load (Lbs.); Based on C to C Dimensions at Max. Temperature of 250°F														
		12	14	16	18	20	22	24	26	28	30	36	42	48	54	60
<b>3</b>	8.2	8800	7500	6600	5800	5200	4800	4400	3900	3600	3500	2900	2500	2200	1900	1700
<b>4</b>	10.8	15200	13100	11400	10200	9100	8300	7500	7000	6500	6100	5100	4300	3800	3300	3000
<b>5</b>	13.4	--	--	--	16000	14400	13100	12000	11100	10300	9600	8000	6800	6000	5300	4800
<b>6</b>	21.0	--	--	--	26600	24000	21800	20000	18400	17100	16000	13300	11400	10000	8800	8000
<b>8</b>	23.0	--	--	--	--	--	--	32300	29800	27700	25800	25100	18500	16100	14300	12900
<b>10</b>	30.6	--	--	--	--	--	--	53500	49400	45800	42800	35700	30600	26700	23800	21400
<b>12</b>	41.4	--	--	--	--	--	--	--	--	--	--	57000	48900	42800	38000	34200
<b>15</b>	67.8	--	--	--	--	--	--	--	--	--	--	111000	95300	83400	74100	66700



QWI 4.3.1 Issue Date Apr/13 Rev.0

*Note: when referencing a printed copy of this specification page please insure it is the latest version as found on our website at [www.taylorassociates.com](http://www.taylorassociates.com)*

### MEDIUM WELDED BRACKET #801

- Mild Steel
- Bare Metal
- Recommended for the support of pipe loads up to 1500 lbs  
Constructed of facing angle iron with 1" space. The bracket provides maximum lateral adjustment when carrying or suspending pipe.
- Complies with MSS SP-58 and MSS SP-69 (Type 32).
- Specify size number, name, and finish
- Also available in Electro-Plated Zinc, Stainless Steel and Hot Dipped Galvanized.

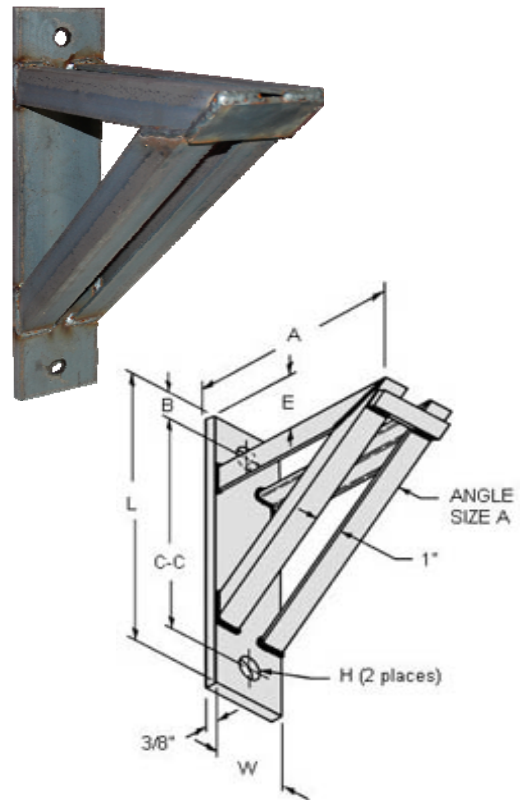

SIZE NO.	SPECIFICATION DATA								WGT EACH (LBS.)
	C-C	A	E	H	B	L	W	ANGLE SIZE S	
1	15 1/2	12	2 1/2	13/16	1 1/4	18	4	1 1/2 x 1 1/2 x 3/16	16
2	21 1/2	18	2 1/2	13/16	1 1/4	24	4 1/2	1 3/4 x 1 3/4 x 3/16	26
3	27 1/2	24	2 1/2	13/16	1 1/4	30	5	2 x 2 x 1/4	45



QWI 4.3.1 Issue Date Apr/13 Rev.0

*Note: when referencing a printed copy of this specification page please insure it is the latest version as found on our website at [www.taylorassociates.com](http://www.taylorassociates.com)*

### HEAVY WELDED BRACKET #802

- Mild Steel
- Bare Metal
- Recommended for the support of pipe loads up to 3000 lbs  
Constructed of facing angle iron with 1" space. The bracket provides maximum lateral adjustment when carrying or suspending pipe.
- Complies with MSS SP-58 and MSS SP-69 (Type 33).
- Specify size number, name, and finish
- Also available in Electro-Plated Zinc, Stainless Steel and Hot Dipped Galvanized.

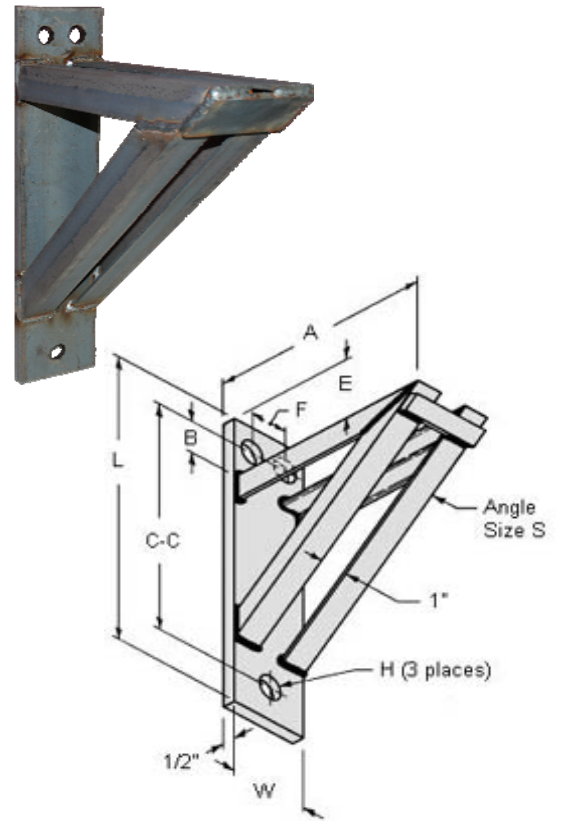

SIZE NO.	SPECIFICATION DATA								WGT EACH (LBS.)
	C-C	A	E	H	B	L	W	ANGLE SIZE S	
1	15 1/2	12	2 3/4	13/16	1 1/2	18	4	2 x 1 1/2 x 1/4	25
2	21 1/2	18	2 3/4	13/16	1 3/8	24	5	2 x 2 x 1/4	38
3	27 1/2	24	2 3/4	1 1/16	1 1/4	30	5	2 1/2 x 2 x 5/16	69
4	33 1/4	30	3	1 1/16	1 1/2	36	5	2 1/2 x 2 x 5/16	82
5	39	36	3	1 1/16	1 1/2	42	6	3 1/2 x 2 1/2 x 3/8	130
6	46	42	3 1/2	1 1/16	2	50	6	3 1/2 x 2 1/2 x 3/8	155



QWI 4.3.1 Issue Date Apr/13 Rev.0

*Note: when referencing a printed copy of this specification page please insure it is the latest version as found on our website at [www.taylorassociates.com](http://www.taylorassociates.com)*



**AIR CONDITIONER BRACKET #AC100 & AC200***Note: Anchor Bolts Not Supplied*

- 16" x 30" and 16" x 36" (supplied with gusset)
- Carbon Steel
- Epoxy Coated
- To support the installation of air conditioners.
- Specify size, figure number, and name.

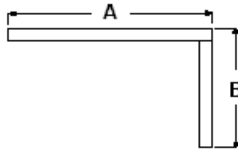

SIZE	SPECIFICATION DATA			APP'X WT. PER SET (LBS)
	MATERIAL	A	B	
<b>AC100</b>	3/16" x 1 3/4" ANGLE IRON	30"	16"	16#
<b>AC200 c/w Gusset</b>	3/16" x 1 3/4" ANGLE IRON	36"	16"	22#



QWI 4.3.1 Issue Date Dec/08 Rev.5

*Note: when referencing a printed copy of this specification page please insure it is the latest version as found on our website at [www.taylorassociates.com](http://www.taylorassociates.com)*