

"Apollo" Valves

MIXING VALVES



"Apollo"® THERMOSTATIC MIXING VALVES

Apollo® Mixing Valves are the perfect solution for:

- Increasing the amount of hot water your hot water heater can supply. By heating the water to a higher temperature, and mixing with water from the cold line, they can double the hot water capacity.
- Prevents Legionella disease. By increasing the temperature in your hot water heater to 140°F, it not only prevents Legionella bacteria from growing but will also kill the bacteria.
- Prevents injury from scalding and thermal shock. Apollo® Mixing Valves offers both hot and cold supply failure shut off protection. If the cold water supply is compromised, it will shut the hot water flow down to a trickle, preventing accidental scalding. If the hot water supply is compromised, it will also shut the cold water flow down to a trickle, helping to prevent any injury in a shower situation.

All Apollo® Mixing Valves are Made in the USA (Pageland, SC) and are ARRA compliant.

ASSE 1017 POINT-OF-SOURCE MIXING VALVES

34ALF
SERIES

34ALF Mixing Valves come with integral strainers and check valves as standard. Provides hot water temperature control of potable and non-potable hot water distribution systems. Fingertip temperature control with maximum temperature limit option.

FEATURES

- Mixed Water Temp Range: 85° - 120°F (29° - 49°C)*
 - Minimum Flow Rate: 0.5 GPM (1.9 LPM)
 - ASSE 1017
 - NSF/ANSI 372 - Lead Free
 - End Connections: Solder, Female NPT, CPVC, PEX (F1807 & F1960), Press, Push
- *High Temperature Version for Hydronic/Radiant Heating Applications. Temp Range: 120°-180°F (49° - 82°C)

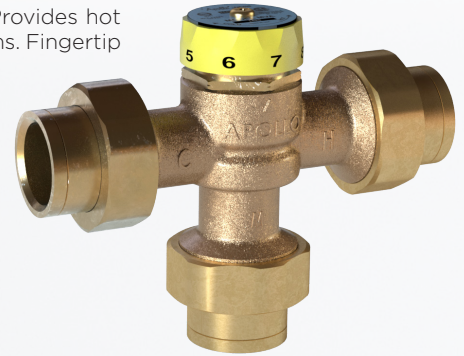

34BLF
SERIES

34BLF Mixing Valves come with integral strainers and check valves as standard. Provides hot water temperature control of potable and non-potable hot water distribution systems. Fingertip temperature control with maximum temperature limit option. **Triple Certified to ASSE 1017, 1069 & 1070** with the highest capacity that meets ASSE 1070.

FEATURES

- Mixed Water Temp Range: 80° - 120°F (27° - 49°C)*
 - Minimum Flow Rate: 0.5 GPM (1.9 LPM)
 - ASSE 1017, 1069, 1070
 - NSF/ANSI 372 - Lead Free
 - End Connections: Solder, Female NPT, CPVC, PEX (F1807 & F1960), Press, Push
- *High Temperature Version for Hydronic/Radiant Heating Applications. Temp Range: 120°-180°F (49° - 82°C)

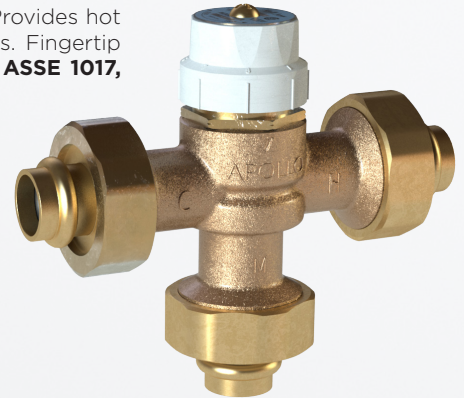

34CLF
SERIES

34CLF Mixing Valves are designed for high capacity commercial and institutional "point-of-source" applications. Featuring ease of maintenance and "best in class" flow rates, providing reliable temperature control for large hot water distribution and hydronic heating systems.

FEATURES

- Mixed Water Temp Range: 90°F - 140°F (32° - 60°C)*
 - Minimum Flow Rate: 1.0 GPM (3.79 LPM)
 - ASSE 1017
 - NSF/ANSI 372 - Lead Free
 - End Connections: Female NPT
- *High Temperature Version for Hydronic/Radiant Heating Applications. Temp Range: 130°-180°F (54° - 82°C)

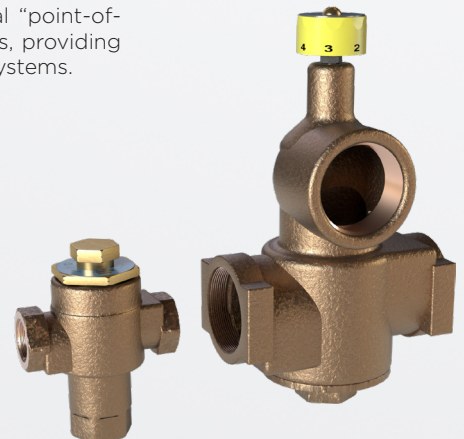

ASSE 1070

POINT-OF-USE MIXING VALVES

34BLF SERIES

34BLF Mixing Valves come with integral strainers and check valves as standard. Provides hot water temperature control of potable and non-potable hot water distribution systems. Fingertip temperature control with maximum temperature limit option. **Triple Certified to ASSE 1017, 1069 & 1070** with the highest capacity that meets ASSE 1070.

FEATURES

- Mixed Water Temp Range: 80° - 120°F (27° - 49°C)*
- Minimum Flow Rate: 0.5 GPM (1.9 LPM)
- ASSE 1017, 1069, 1070
- NSF/ANSI 372 - Lead Free
- End Connections: Solder, Female NPT, CPVC, PEX (F1807 & F1960), Press, Push
- *High Temperature Version for Hydronic/Radiant Heating Applications. Temp Range: 120°-180°F (49°- 82°C)



34DLF SERIES

34DLF Mixing Valves comes with integral check valves as standard. Locking control knob and 120°F (49°C) Temperature limit stop.

FEATURES

- Mixed Water Temp Range: 80° - 120°F (27° - 49°C)
- Minimum Flow Rate: 0.25 GPM (0.94 LPM)
- ASSE 1070
- Lead Free (NSF/ANSI 61 & 372)
- End Connections: 3/8" Compression Tube/Braided Hose Connection.
- Bypass Fitting Option for Dual Control Faucets Available.

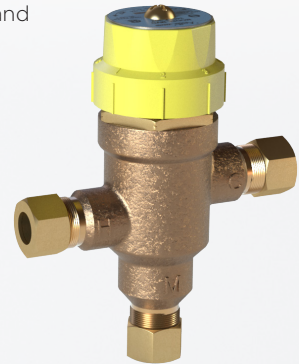

TANKMAX

The Apollo® Tank Max Thermal Mixing Valve significantly increases your water heater's effective volume of delivered 120°F hot water by mixing cold water with 140°F or higher hot water. Keeping the water in your water heater's tank at 140°F provides protection against the growth of Legionella which can lead to Legionnaires' disease. The thermostatic mixing valve on the Apollo® Tank Max also ensures water will be delivered to all fixtures is at a safe temperature, protecting against scalding and thermal shock.

FEATURES

- Mixed Water Temp Range: 90° - 130°F (32°-55°C)
- Minimum Flow Rate: 1.0 GPM (4.0 LPM)
- ASSE 1017
- Lead Free (NSF/ANSI 61 & 372)
- End Connections: 3/4" MNPT Outlet x FNPT Union Fitting x 3/4" NPSH Inlet



TEMP GAUGE

The Apollo® Temperature Gauge accessory is used to easily measure the mixed water temperature from a mixing valve. The gauge can be used on the Apollo® 34ALF & 34BLF Series Mixing Valves sizes 1/2" & 3/4", is lead free and complies with NSF/ANSI 372 requirements.



34BLF

S E R T I E S

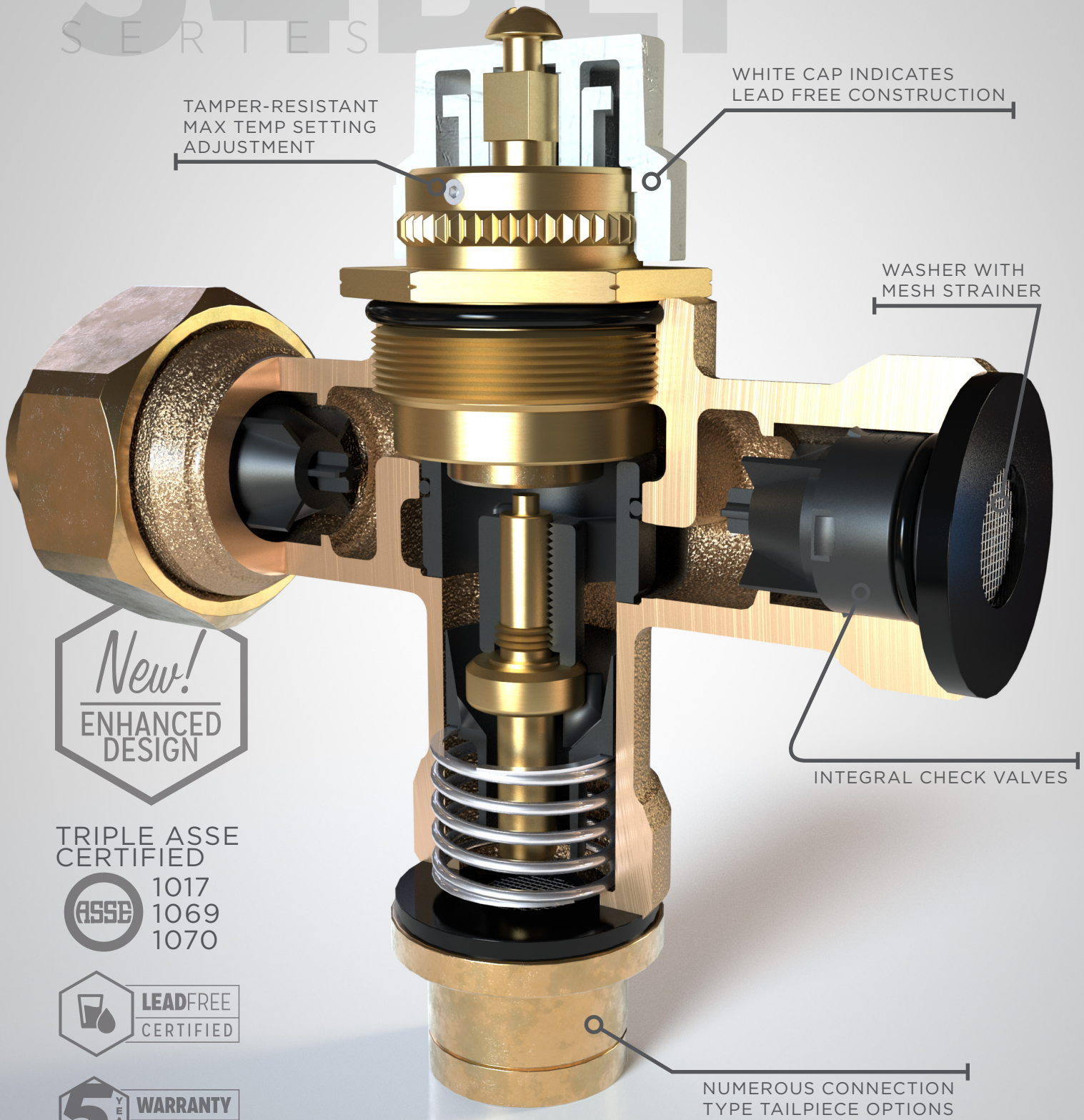

New!
ENHANCED
DESIGN

TRIPLE ASSE
CERTIFIED



customer service (704) 841-6000
www.apollovalves.com

