

Flexitallic®

CORPORATE CAPABILITIES



International manufacturer
& supplier of high quality
static sealing products

www.flexitallic.com

A member of the

FDS
Group

Flexitallic is the international market leader in the manufacture and supply of high quality, high value industrial static sealing products, delivering industrial gaskets on a global scale.



About us

As the developer of the spiral wound gasket in 1912, we have built on this legacy of innovation with revolutionary products including Thermiculite® and Sigma® and most recently the CPR-HF and Change gaskets.

We have a global customer service network of owned manufacturing facilities, manufacturing licensees and a network of over 750 distributors across 30 countries. This ensures local demand is met quickly, providing a combination of the highest product quality and outstanding customer service.

“Creating an effective, safe and sustainable environment exceeding the needs of industry”

Our extensive and varied product offering of The FDS Group includes spiral wound gaskets, Sigma (PTFE filled gaskets), Thermiculite (for high temperature applications), RTJ gaskets, Flexpro™ Kammprofiles, sheet materials and dynamic and static packings. Drawing upon the group's rich history and present day values of leadership, quality, service and technology, we are at the forefront of developing sealing solutions for industries around the world.

In addition to a wide range of products, we also deliver world-class technical support and training.

International manufacturer and supplier of high quality, static sealing products

“Our core philosophy is to not only supply the product, but also offer a complete solution, from design to manufacture, supply, installation and on-site support.”

Innovative Product Range

We have a rich history of innovation, which has seen us lead the industry with many new products.

Over the years, our products have gained a reputation for quality, reliability and technology that is second to none.

Customized Engineering Solutions

Our Application Engineering, Production Engineering and R&D teams work closely together to design, develop and manufacture customized sealing solutions.

We have been responsible for a number of truly revolutionary products, including Thermiculite®, Sigma® and the CPR-HF Gasket, which ensure we are able to continually meet the ever more stringent requirements of our customers.

Our Commitment to Quality

We place great emphasis on maintaining international quality standards such as ISO 9001, API 6A and API 17D, to ensure we meet the highest possible standards for all our products and services.

We also invest heavily in test and quality assurance equipment to maintain our reputation for the highest quality products.

Our materials are subjected to a wide range of tests as specified by statutory regulations and customer requirements. These approvals enable our customers to make informed choices as to the suitability of a product for each and every application.

Inside Industry

We pride ourselves on not simply supplying products, but by supporting customers with a detailed knowledge of their industry and application, so that products and services are tailored to their specific needs.

This unique approach means that we focus on providing more than just a product, but also a complete solution that adds genuine value to our clients.

Allied Distributor



Global Distribution... Local Support

Our products are distributed through a global network of Allied Distributors and Licensees.

These carefully selected distribution and manufacturing partners are strategically located within their territory to deliver the best possible service and products to our customers. This approach means our products and know-how is available to the global industries we service.

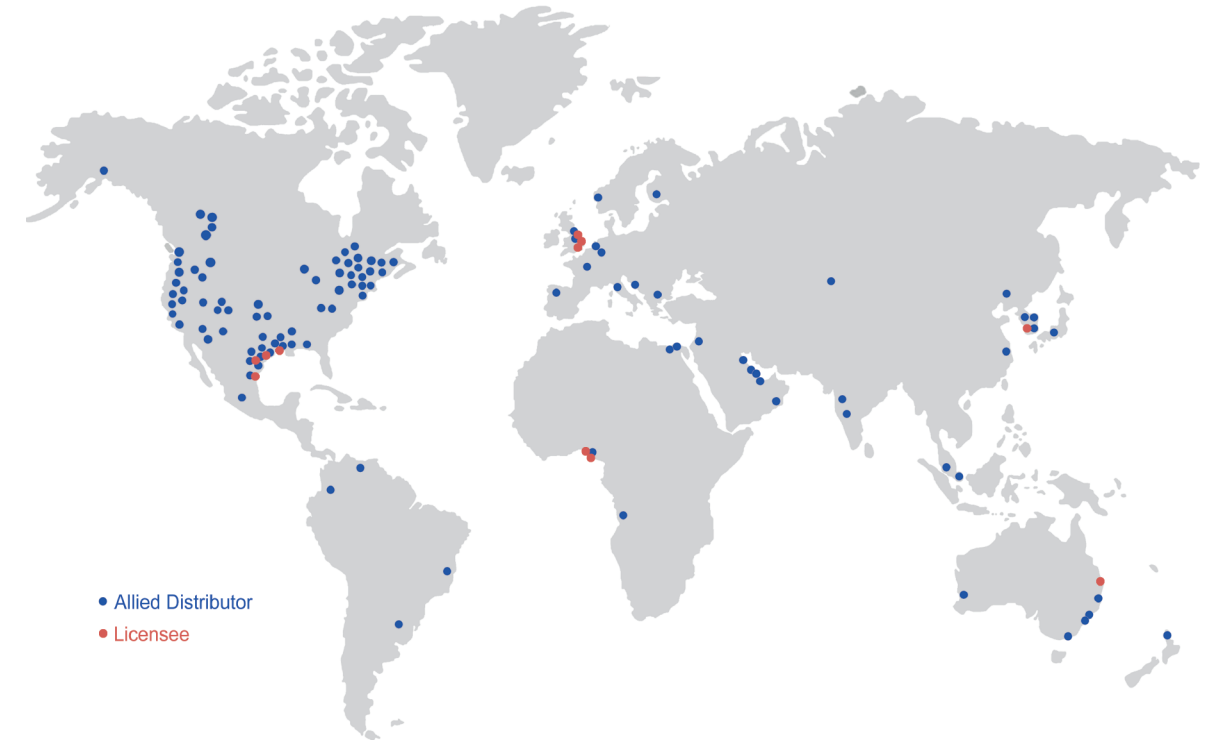

CHANGE GASKET

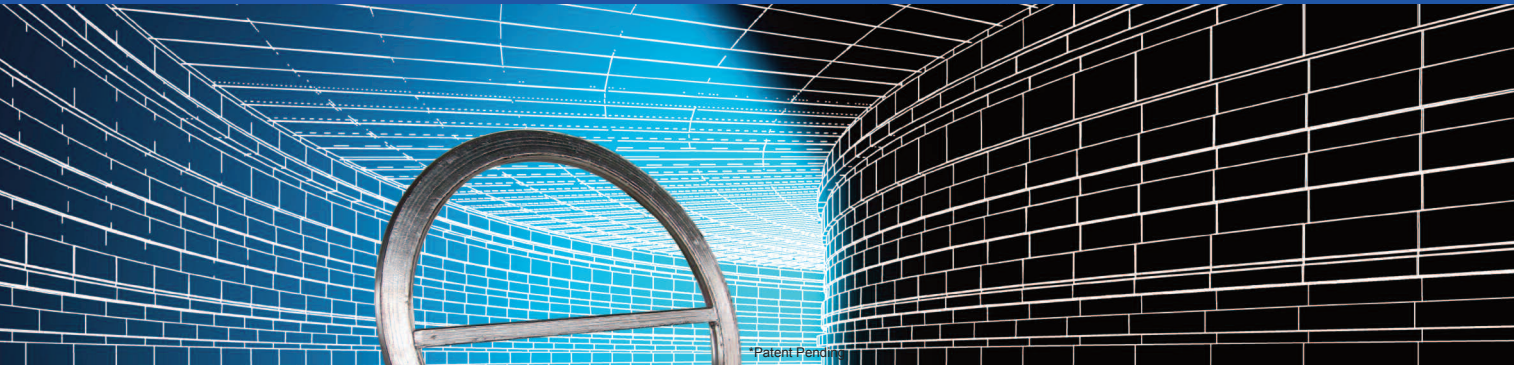

Engineered Like Nothing Else.

To Perform Like Nothing Else.

What A Change.

When we invented the spiral wound gasket in 1912 there was nothing like it. 100 years of innovation later, we introduce the Change™ gasket. And again there's nothing like it. Incredibly robust and resilient, metal-wound Change™ heat exchanger gasket is designed to deliver the most dynamic seal ever. Manufactured with proprietary equipment, using a 5-times thicker metal spiral and a unique laser welding process that penetrates completely through. So it requires no inner or outer ring, and is as easy to handle and install as a double-jacketed gasket. Best of all, it's proven to perform without fail at least 60% longer than any other heat exchanger gasket. Spiral wound. Double jacketed. CMG. Or Kammprofile. And that's a game changer.

In a compression test against all other heat exchanger gaskets, the Change gasket recovered over three times better than the double jacketed gasket. 64% better than the conventional spiral wound gasket. 39% better than the CMG gasket. And 30% better than the Kammprofile gasket.

chang⊕

THE CHANGE GASKET. UNIQUELY MANUFACTURED.

SHAPE



- + 5x Thickness change
- 304 - 316L & Others
- Develops a Uniquely Solid Gasket

LASER WELDED



- Higher unit adhesion
- Pin point accuracy
- Solid unit construction

SPIRAL WOUND GASKETS



Driven by the industry's need for safe, effective sealing solutions for increasingly demanding applications, Flexitallic invented the spiral wound gasket in 1912.

Not satisfied with inventing the iconic spiral wound gasket, we have continued to innovate by developing world leading materials.

Thermicilite® is often used as a filler material to provide resistance to temperature, chemical attack and corrosion.

Through precision engineering, the spiral wound gasket, available in unlimited configurations of high quality metals and materials, is individually tailored to meet the demands of each application.

Globally acknowledged to provide a superior seal in the most exacting of conditions, its flexibility and recovery gives it a unique ability to cope with the effects of high pressure, wide temperature fluctuations and bolt relaxation.

Spiral wound gaskets are found in a host of applications across the world, from small diameter turbine gaskets, to HP heat exchangers.

Product Range:

- Standard gaskets available to a range of international standards including ASME / EN
- Low stress sealing element
- Heat exchangers
- Carrier rings
- OEM
- Application specific designs

Benefits:

- Engineered and Manufactured in the USA
- 24/7 manufacturing capability for special requirements
- Significant stock holding of standard gaskets
- Flexibility to manufacture and supply gaskets with a combination of inner and/or outer guide rings
- Wide range of machinery that enables us to manufacture any size gasket
- Global distribution manufacturing
- Custom designs available
- World-class testing and development center
- Support from our team of Application Engineers

Leak-free start up

“By using custom designed heat exchanger spiral wound gaskets, we achieved a leak free start up – a first in 15 years.”

Chief Engineer
Leading Refinery

THERMICULITE®



Another first for Flexitallic. Thermiculite® - the complete sealing solution.

Thermiculite®
innovative. versatile. complete.

Thermiculite® is specified by name where critical sealing matters. Applications include Petro Chemicals, Fertilizers, OEM, Oil & Gas and Power applications, where process conditions are extreme.

Our experienced engineers use the versatility of Thermiculite® to create special sealing configurations in equipment and piping systems to increase operational up-time for our customers. This truly remarkable product has proven itself as an effective long-term sealing solution in over 500 of the most demanding industrial sealing applications.

Thermiculite® is a patented product with amazing versatility. Not only can it withstand high temperatures and corrosive environments, due to our unique formulation, we are able to offer Thermiculite® as a stand alone sheet material, as a filler for SWG's, as a facing for Flexpros and also in many of our other product lines.

We have also developed a range of valve stem packings, using Thermiculite® technology for use in the most arduous service.

Products:

- 700-800 Series - sheet grade
- 866 - special grade (SOFC)
- 896 - aerospace
- Kammpfiles
- SWG
- Static and Dynamic Packings
- I-Flex Isolation Kits
- CPR

Benefits:

- Fire-safe
- Wide temperature range - cryogenic to 1000°C (1800°F)
- TAluft approved
- Wide availability of styles of gaskets
- Free from oxidation
- Excellent chemical compatibility
- Electrical and thermal insulation
- Universal
- Replaces graphite, PTFE, non-asbestos materials

PROVEN TRACK RECORD IN THE FOLLOWING INDUSTRIES

- **Power Generation**
- **Fertilizer (Aggro-Chemicals)**
- **Oil Exploration**
- **Industrial Chemicals**
- **Automotive**
- **Aerospace**
- **Oil Refining**
- **Emerging Technologies (Solid Oxide Fuel Cell)**

SIGMA®



For applications where chemical resistance is paramount, SIGMA® is the only option.

SIGMA

Utilizing a unique manufacturing process exclusive to Flexitallic, SIGMA® represents the latest generation of biaxially orientated PTFE materials.

All components in the SIGMA® range are FDA compliant. The material's clean nature makes it ideal for use where product contamination is of concern, such as food, pharmaceuticals and electronics.

The chemical resistance and dimensional stability of the material ensures total sealing reliability and minimizes fugitive emissions.

Products:

- 500 511 533 588 600

Benefits:

- Cryogenic to 260°C (500°F)
- Outstanding chemical resistance across PH range
- Suitable for low bolt load applications
- Materials available in a range of different sheet sizes and thicknesses
- FDA compliant
- Available for oxygen service
- Easy to handle and cut

COMPRESSED FIBER

Our range of compressed fiber materials is designed for a wide range of industrial and original equipment applications where sealing performance and specification is essential.

A comprehensive range of grades is available covering a wide spectrum of applications.

Products:

- SF1630 SF2400 SF3300 SF5001 AF2100

Benefits:

- Wide range of service applications
- Easy to handle and cut
- Good bolt torque retention
- Reliable for general service chemicals

GRAPHITE

Exfoliated graphite products are designed for demanding, general industry applications typical of the petrochemical and refining industries.

Manufactured from high purity exfoliated graphite, our products are available with a variety of metallic inserts and combinations of thickness.

Ultra high purity graphite is available for the nuclear industry, and high pressure grades are also available.

Products:

- Flexicarb ST Flexicarb SR Flexicarb NR

Benefits:

- Wide chemical resistance
- Good compressibility
- Resistent to thermal shock
- Excellent stress retention

FLEXPRO™ KAMMPROFILES



The versatile gasket with three key features:

- compressibility
- low stress
- convenience



The FLEXPRO™ Kammprofile gasket has three key features: the compressibility of a sheet gasket; the sealability of a spiral wound gasket and the ease of handling a solid metal gasket.

FLEXPRO™ gaskets are the ideal product choice for standard pipeline and heat exchanger applications. They provide the highest levels of sealing integrity but with the ability to seal at seating stresses normally associated with sheet materials. Kammprofiles are able to cope with fluctuating temperatures and pressures making them the gasket of choice for heat exchanger service. The product can also be reused when correctly refurbished.

Products:

- Style PN – serrated profile used in confined locations eg heat exchangers
- Style ZA – serrated profile with loose outer ring
- Style ZG – serrated profile with integral outer ring

Benefits:

- Engineered and Manufactured in the US
- Wide stock of raw materials
- Adherence to the tightest global specifications
- Inspection equipment allowing exact measurement of machined profiles
- TADU machine for very large diameter gaskets
- Thermiculite® technology for high temperature applications
- Custom shapes
- Wide range of machinery
- World class testing and development center
- Support from our team of Application Engineers

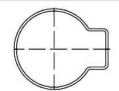

CUSTOM SHAPES –

We have developed specialist manufacturing techniques, enabling us to produce FLEXPRO™ Kammprofile gaskets in a wide range of non-circular shapes and sizes.

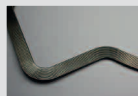

These are particularly useful for applications that need the narrow sealing element and low stress seating of a kammprofile, but traditionally have had to use lower grade products such as jacketed or metal reinforced gaskets. Applications include oval, obround and square manway and boiler door joints and large rectangle gaskets for fin-fan header boxes.

Contact our Application Engineering Team to discuss specific requirements.

CASE STUDY: WEDGE KAMMPROFILE

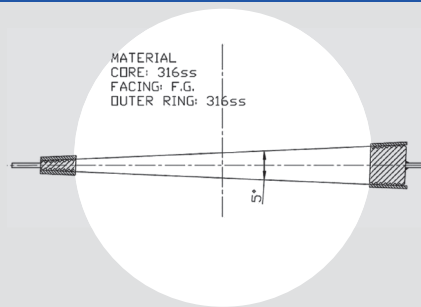

We were contacted late one Friday with the problem, by Sunday the product had arrived on site in Nigeria.

The issue was the misalignment of the mating component which meant a standard gasket could not be used, a bespoke Kammprofile was the perfect fit.

This highlights our capability to turn a customer problem into a innovative solution.

“This novel solution certainly solved a problem that looked like it might prevent the successful start up after shutdown.”

Site Shutdown Coordination Engineer

CPR-HF GASKETS



CORROSION MANAGEMENT GASKET

The CPR-HF Gasket, an industry-first from Flexitallic, revolutionized inspection and corrosion management, changing the face of flange maintenance in oil and gas environments, forever.

The CPR-HF range of high performance sealing solutions is our latest innovation for challenging, corrosive environments. Developed in direct response to the oil and gas industry's requirement for effective closure on damaged flange faces, with additional corrosion inhibiting properties, it is now helping to mitigate corrosion problems throughout industry.

The fight against corrosion is a constant battle. Internal corrosion and damaged flange faces are responsible for a significant proportion of hydrocarbon releases and can have a major impact on operating costs, particularly on aging assets.

The CPR-HF can be used to seal on damaged flange faces where previously only very costly or time consuming options existed.

By using the CPR-HF range it helps you to fight the corrosion battle head on.

Benefits:

- Engineered and Manufactured in the US
- Significant cost savings
- Speeds up maintenance downtime
- Fire-safe to API 6FB
- Topside/subsea variants
- Special designs available

For more information visit www.flangerescuegasket.com

RING TYPE JOINTS



The metallic RTJ is used in the petroleum industry, where high pressure applications necessitate the need for a high integrity seal.

Every RTJ that leaves our manufacturing facility is identified with key product information to give you the confidence that our products meet stringent application requirements.

In addition, every material that enters our factory is checked using the latest Positive Material Identification (PMI) technology, which combined with our material database, ensures we have full product traceability.

RTJ's were initially developed for use in the upstream petroleum industry and are also commonly used on valves and pipework assemblies, and high integrity pressure vessels.

Product Range:

Style R, RX, BX, Subsea and OEM design

Benefits:

- API 6A and 17D approvals
- Specialist coatings available including Xylan, silver and zinc
- Wide stock of raw materials
- Wide range of CNC machines
- The latest inspection technology - CNC/CMM
- Custom designs available
- World-class testing and development center
- Support from our team of Application Engineers

TECHNICAL SERVICES & SUPPORT

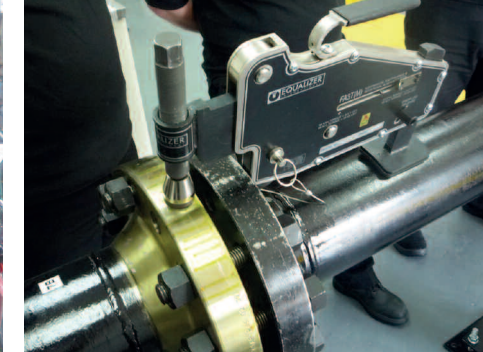

Research and Development

We continue to make significant investments in technology, in order to support future development of materials and to set new industry benchmarks for the evaluation of existing products.

Our World Class testing center, based in Scandinavia Mill, West Yorkshire, United Kingdom ensures we remain at the forefront of innovation in the supply of sealing solutions for industries around the world.

We utilize state-of-the-art rigs, including the AMTEC and a 3MN gasket test rig.

Our test capabilities include:

- Gas Leakage
- Liquid Leakage
- Tensile Strength
- Creep Relaxation
- Stress Retention
- Compression and Recovery
- Flexibility
- Immersion Tests
- Shell Thermal Cycle Test
- EN1591
- EN13555

Custom Design

We have a world-class capability to supply solutions for all applications. Our Application Engineers have a wide range of experience in different industries and applications to enable us to provide a comprehensive design service.

In many instances, special designs are required, and because we have a dedicated Application Engineering Team, R&D, and comprehensive manufacturing facility, we are able to manufacture various sizes and styles of gaskets in a variety of materials.

We have a proven track record for designing and manufacturing custom solutions.

For more details please contact our Application Engineering Team.

“Flexitallic engineers provide a value for money, engineered solution to customers on a global basis, giving advice on gasket selection, gasket usage and trouble shooting on those difficult applications.

With over 6000 documented solutions accessible on our Global Engineering database the list of satisfied customers continue to grow.”

Shutdown Support

Major maintenance events require not just the supply of good quality products, but also practical support before, during, and after the shutdown.

We have developed a range of services, designed to support major refinery and process customers during shutdown periods.

Service benefits are:

- 24/7 manufacturing capability for an extensive range of gasket types
- Emergency manufacturing when required
- Experienced Field Engineers available 24 hours
- Quick turnarounds
- Significant cost savings
- Pre service assessment

THE ACADEMY OF JOINT INTEGRITY

“Fundamental to successful joint integrity is the training of the personnel involved in the process of inspection, assembly and tightening of bolted connections.

To address Human Factor issues, The Academy provides a range of cost effective tailored training courses to suit the needs of the client/contractor.”

Training Courses

The Academy of Joint Integrity offers Accredited and Awareness Training Courses to all personnel who are actively involved in the assembly and tightening of flanged bolted connections. Mentoring and assessment programmes also complement the training provision. All our training courses are given by industry professionals who themselves have current and relevant industry-based experience.

Courses

Training can be delivered in a variety of ways:

- At the Academy, utilizing our purpose built training centers
- At the clients premises, utilizing mobile training rigs and equipment

Benefits

- Motivated workforce with best practice skills
- Reduced costs with increased asset integrity
- Access to the latest technical standards and procedures
- Sealing and integrity modules providing greater knowledge
- Alliance and structured support from a world class technical / training team

For further information on the range of courses available visit www.flexitallic.com



The Academy of Joint Integrity™



UNITED KINGDOM
Flexitallic UK, Ltd

Scandinavia Mill
Hunsworth Lane
Cleckheaton
West Yorkshire
BD19 4LN
UK

Tel. +44 1274 851273

Fax. +44 1274 300303

CANADA
Flexitallic UK, Ltd

4340 - 78 Avenue
Edmonton, Alberta
T6B 3J5
CANADA

Tel: +1 780 466 5050

Fax: +1 780 465 1177

UNITED STATES
Flexitallic US, LLC

6915 Highway 225
Deer Park
Texas 77536
USA

Tel. +1 281 604 2400

Fax. +1 281 604 2415

CHINA
**Flexitallic Sealing
Technology Co. Ltd**

Building 3 South
Wujiang Export
Processing Zone
688 Pangjin Road
Wujiang, Jiangsu 215200
P.R. CHINA

Tel. +86 512 6303 2839

Fax. +86 512 6303 2879

www.flexitallic.com

The FDS Group

Flexitallic is a member of the FDS Group. All member companies play a part in the improvement of industrial processes and safety of operations in diverse sectors such as oil production, oil refining, petrochemical and energy. Client service, technical support and innovative solutions, in all aspects of the industrial sealing business, are the core of the strategy shared by the companies that are part of the Group.

