

# Series 766

Bidirectional Slurry Valve



**Bray / VAAS®**

3"-24" (80-600mm) 150psi (10bar)

# Series 766

## Bidirectional Slurry Valve

The Bray/VAAS Series 766 is a bidirectional slurry valve, designed for demanding slurry applications. Twin elastomer seats and push-through gate design facilitate self-cleaning and prevent media build up.

The durable ductile iron body is offered in a compact wafer style. When fully open, the valve bore offers no resistance to line media.

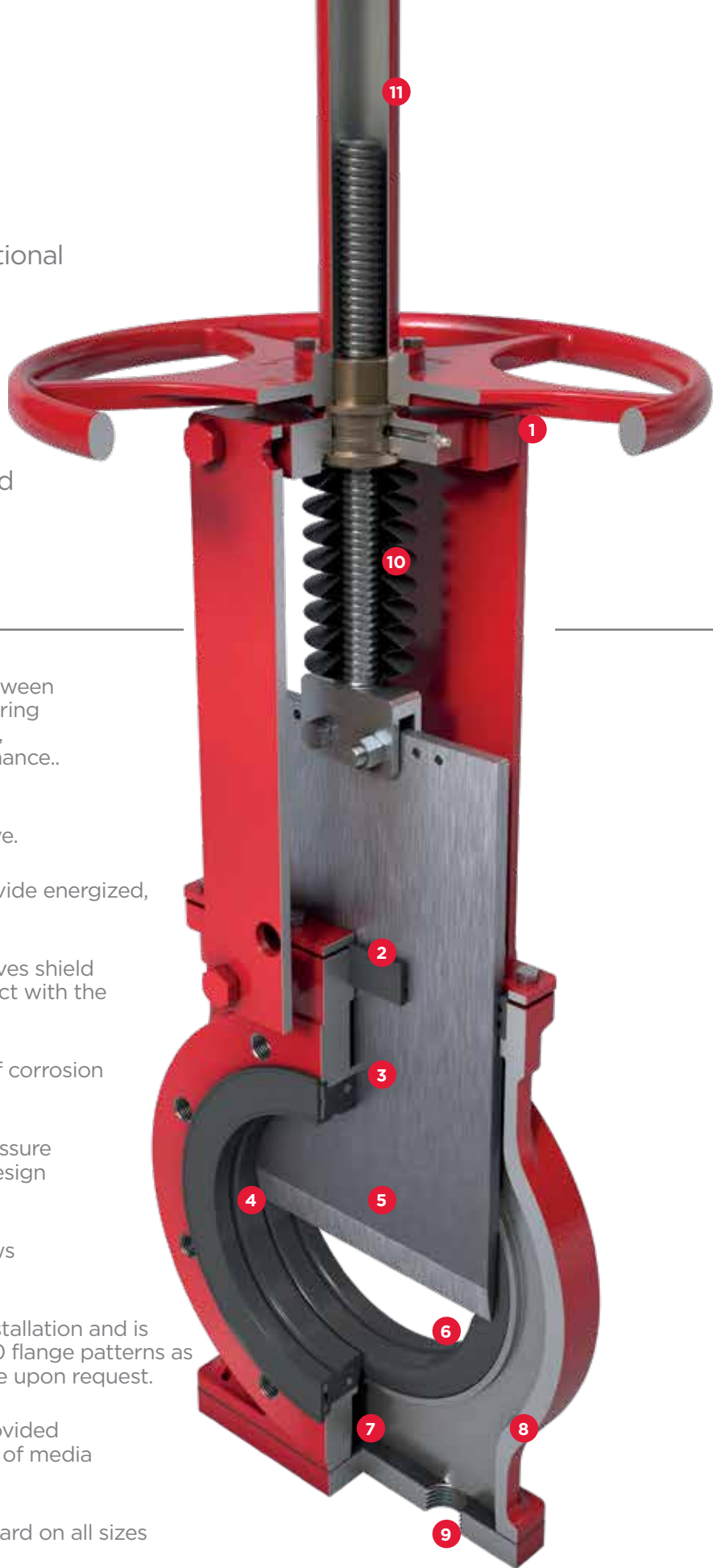

- 1 Designed for easy, quick conversion between manual and pneumatic actuation. Featuring a lubricant injection port for continuous, smooth operation with minimal maintenance..
- 2 Secondary wiper seal extends gate life and prevents discharge from top of valve.
- 3 Metal-reinforced, elastomer sleeves provide energized, zero leakage shutoff in both directions.
- 4 In the open position, the energized sleeves shield all metal components from direct contact with the flowing process media.
- 5 Robust gate available in a wide range of corrosion resistant alloys to suit the application.
- 6 Unrestricted flow path with minimal pressure drop achieved through full port valve design for extended sleeve life.
- 7 Ample clearance for push-through allows complete gate closure.
- 8 Compact wafer body allows for easy installation and is drilled and tapped to ASME B16.5 CL150 flange patterns as standard. Other drilling options available upon request.
- 9 Drain plate with tapped purge ports provided as standard, allowing for safe discharge of media and easy flush water connection.
- 10 Protective rod boot/stem cover is standard on all sizes
- 11 Upper stem protection is standard on all sizes.

## Standard Construction

Body	Gate	Seat	Stem	Wiper Support	Wiper	Topworks
DI	304	Nat. Rubber	304	CS	EPDM	Steel

## Body Options

Carbon Steel (WCB)
CF8 Stainless Steel
CF8M Stainless Steel
CF3M Stainless Steel
SAF 2205 Duplex
SAF 2507 Duplex

## Gate Options

316, 317 Stainless Steel
SAF 2507 Duplex
SAF 2205 Duplex
17-4PH Stainless Steel
Hastelloy® C
Monel®

Additional material options may be available upon request. Consult factory for availability.

## Actuator Options

Direct Mounted
Handwheel - Standard (3"-10")
Bevel Gear - Standard (12"-24")
Pneumatic
Hydraulic
Electric

## Seat Options

Nat. Rubber	165°F/74°C
EPDM	248°F/120°C

## Specifications & Standards

Size Range	3" to 24" (80 - 600mm)
Pressure Rating	150psi (10bar)
Body Style	One-piece (Wafer)

Design	Manufacturer Standard
Testing	MSS SP-81
Face-to-face	MSS SP-81
Drilling	ASME B16.5 CL150

## Dimensions

In. (mm)	A	B	C	D	ØE	F	G	H	I
<b>3</b>	2.24	6.02	7.87	23.62	11.77	27.56	--	--	--
<b>80</b>	57	153	200	600	299	700	--	--	--
<b>4</b>	2.24	7.50	9.06	27.17	11.77	30.91	--	--	--
<b>100</b>	57	191	230	690	299	785	--	--	--
<b>6</b>	2.52	9.50	11.22	33.07	15.98	39.17	34.65	11.65	20.00
<b>150</b>	64	241	285	840	406	995	880	296	508
<b>8</b>	2.99	11.75	13.58	38.19	20.00	51.57	46.85	12.05	20.00
<b>200</b>	76	299	345	970	508	1310	1190	306	508
<b>10</b>	2.99	14.25	15.94	44.88	20.00	51.57	46.85	12.05	20.00
<b>250</b>	76	362	405	1140	508	1310	1190	306	508
<b>12</b>	3.27	17.01	19.09	--	--	59.76	52.56	12.05	20.00
<b>300</b>	83	432	485	--	--	1518	1335	306	508
<b>14</b>	3.27	18.74	21.06	--	--	64.17	58.46	12.05	20.00
<b>350</b>	83	476	535	--	--	1630	1485	306	508
<b>16</b>	3.74	21.26	23.62	--	--	73.23	63.39	12.99	20.00
<b>400</b>	95	540	600	--	--	1860	1610	330	508
<b>18</b>	3.78	22.76	25.51	--	--	75.98	70.87	12.99	20.00
<b>450</b>	96	578	648	--	--	1930	1800	330	508
<b>20</b>	4.76	25.00	28.15	--	--	80.71	78.74	13.46	20.00
<b>500</b>	121	635	715	--	--	2050	2000	342	508
<b>24</b>	4.76	29.50	33.07	--	--	96.06	87.40	13.46	20.00
<b>600</b>	121	749	840	--	--	2440	2220	342	508

## Weights

SIZE	in mm	3 80	4 100	6 150	8 200	10 250	12 300	14 350	16 400	18 450	20 500	24 600
HANDWHEEL	lb	54	75	110	203	247	--	--	--	--	--	--
	kg	24.5	34	50	92	112	--	--	--	--	--	--
PNEUMATIC ACTUATOR	lb	84	104	139	295	335	512	655	827	815	1157	1576
	kg	38	47	63	134	152	232	297	375	370	525	715
GEAR OPERATOR	lb	--	--	--	--	298	368	496	650	657	756	1334
	kg	--	--	--	--	135	167	225	295	298	343	605

Approximate weights shown. Consult factory for additional configurations.

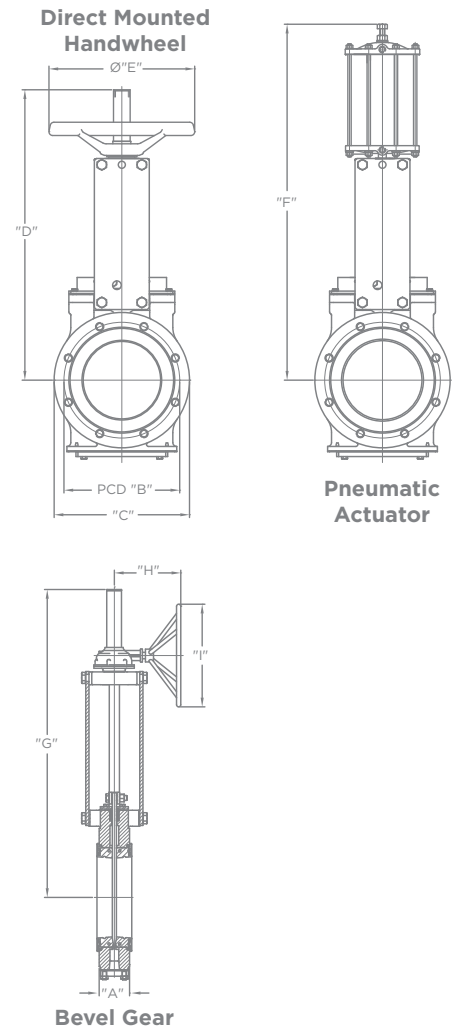



**Bray International, Inc.**  
Houston, TX, USA +281.894.5454

**Bray/VAAS India**  
Chennai +91.44.2496.1391

**Benelux**  
Heerhugowaard +31.72.572.1410

**Brazil**  
Paulinia Sp-Brazil +55.19.3517.6161

**Canada**  
Montréal +514.344.2729

**Chile**  
Santiago +56.2739.2966

**China**  
Hangzhou, Zhejiang +86.571.828.52200

**Colombia**  
Bogota +571.876.6084

**France**  
Maubeuge +0033.3.27.59.41.89

**Germany**  
Krefeld +49.2151.53360

**India**  
Gujarat +91.2667.664444

**Italy**  
Milano +39.02.9237.0196

**Mexico**  
Zapopan, Jalisco +52.33.3836.4460

**Middle East**  
Dubai +00971.0.4.887.6979

**Pacific**  
Melbourne, Australia +613.9580.9755

**Peru**  
Lima +511.251.0251

**Poland**  
Oswiecim +48.33.842.1968

**Russia**  
Moscow +7.495.36.36.222

**Singapore**  
Ubi Techpark +65.6742.1428

**South Africa**  
Sandton +27.10.007.3222

**South Korea**  
Seoul +82.2.2190.3809

**United Kingdom**  
Inchinnan +44.141.812.5199



**Bray World Headquarters**  
Houston, TX - USA



**Bray India**



**Bray/VAAS India**

To find a distributor in your area visit us online at [www.bray.com](http://www.bray.com)

All statements, technical information, and recommendations in this bulletin are for general use only. Consult Bray/VAAS representatives or factory for the specific requirements and material selection for your intended application. The right to change or modify product design or product without prior notice is reserved. Patents issued and applied for worldwide.  
Bray® is a registered trademark of BRAY INTERNATIONAL, Inc. © 2015 Bray International. All rights reserved. V-6012\_EL\_766\_03-2017